

REV	MCO	DWN	DATE
B	20052670	CDZ	22/NOV/99
C	20262929	JSL	15-APR-09

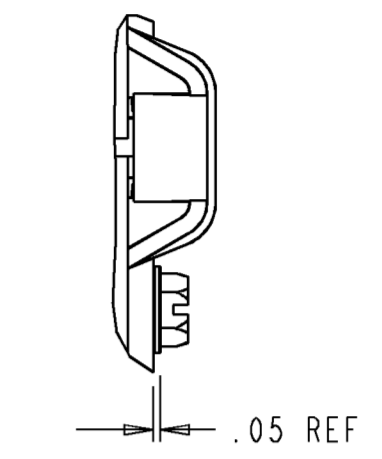
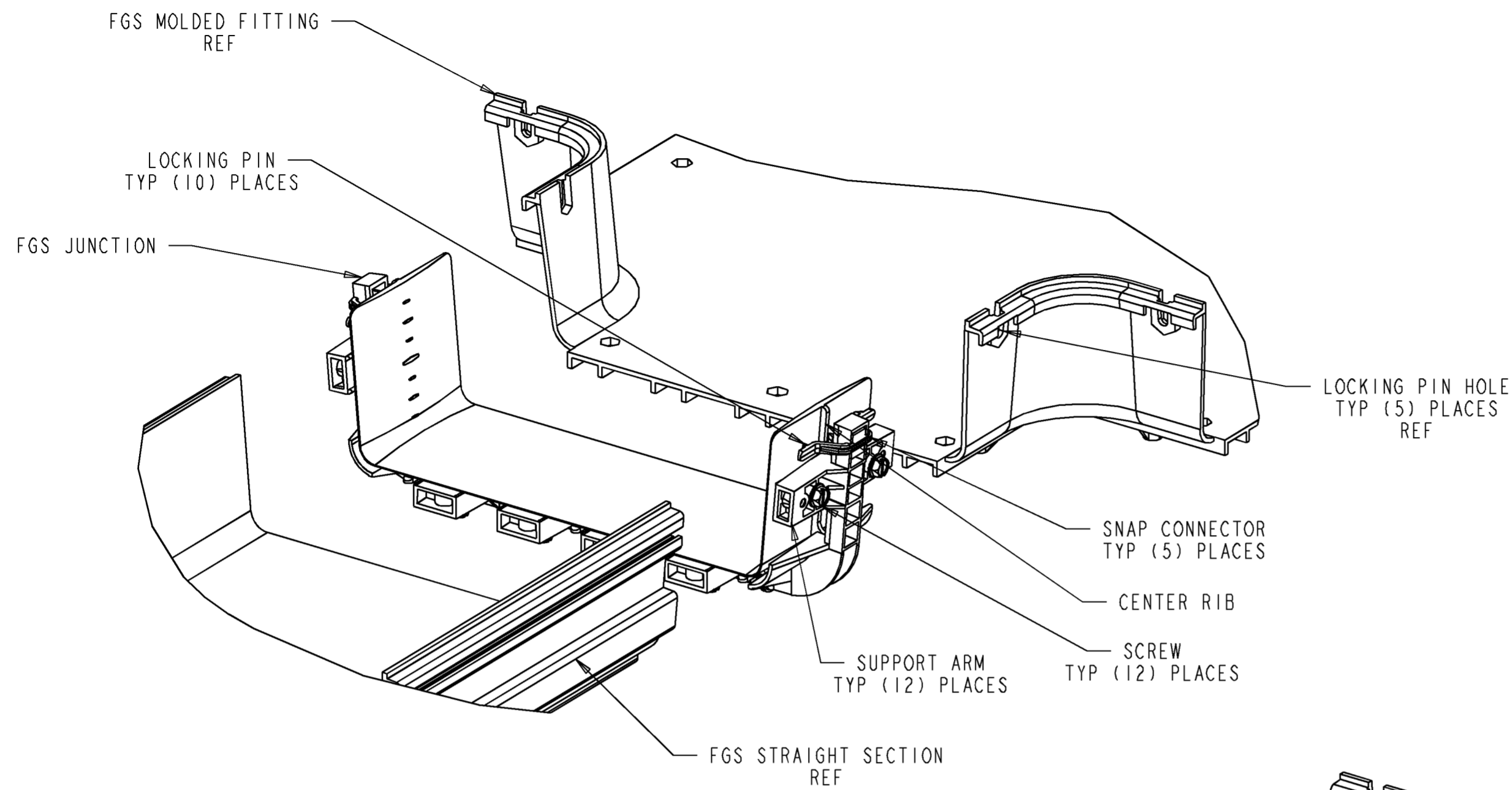
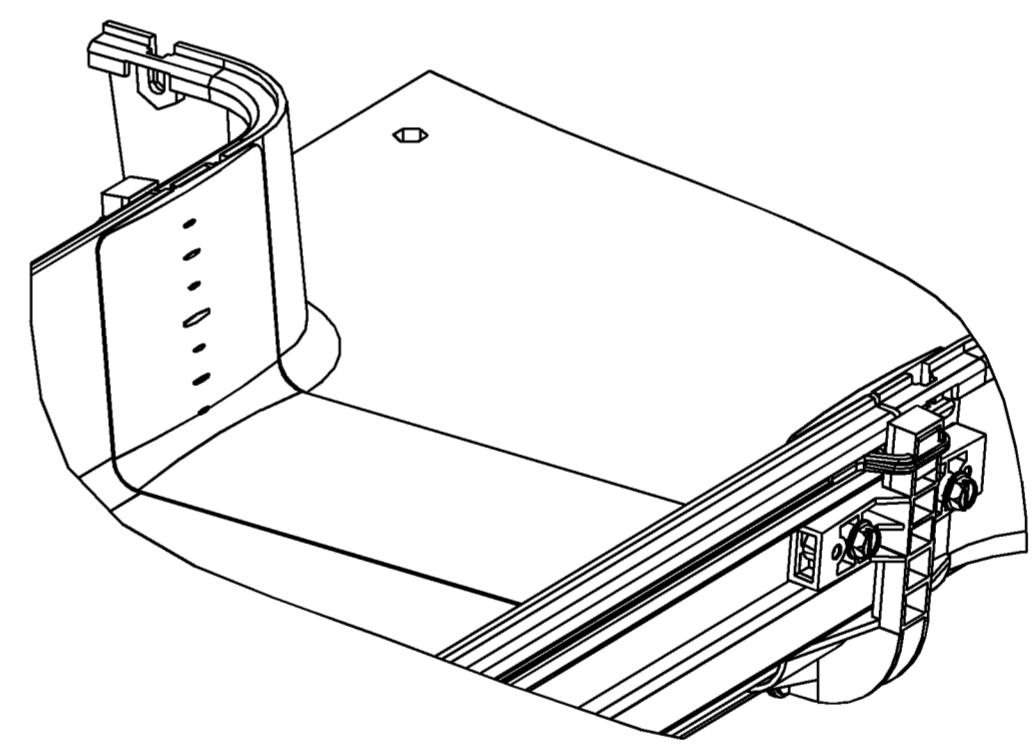

FIGURE 2
INITIAL TIGHTENING
TYP (12) PLACES

FIGURE 1



COMPLETED ASSEMBLY

INSTALLATION NOTES:

1. SLIDE BOTH FGS COMPONENTS INTO JUCTION UNTIL FIRMLY STATED AGAINST THE CENTER RIB. IF COMPONENT IS A MOLDED FITTING MAKE SURE LOCKING PINS ON SNAP CONNECTOR ARE ENGAGED IN HOLES ON MOLDED FITTING (SEE FIGURE 1).
2. TIGHTEN (12) SCREWS SUCH THAT THE WASHER HEAD ON SCREW IS APPROXIMATELY 1/20" FROM SUPPORT ARM (SEE FIGURE 2). AFTER ALL SCREWS HAVE BEEN TIGHTENED TO 1/20" DIMENSION GO BACK AND TIGHTEN SCREWS UNTIL THE WASHER HEAD BOTTOMS OUT ON THE SUPPORT ARM.

CATALOG	COLOR
FGS-JUNC-F	YELLOW
FGSO-JUNC-F	ORANGE
FGSB-JUNC-F	BLACK



INFORMATION ON THIS DOCUMENT IS PROPRIETARY TO ADC AND SHALL NOT BE USED, COPIED, REPRODUCED OR DISCLOSED IN WHOLE OR IN PART WITHOUT WRITTEN CONSENT OF ADC.		TITLE JUCTION, SCREW, 4X12 INSTALLATION DRAWING	
ALL DIMS AND TOLERANCES ARE INCHES UNLESS OTHERWISE SPECIFIED	.XX:± N/A .XXX:± N/A ANGULAR:± N/A	C SIZE	DRAWING NUMBER 1044463
DO NOT SCALE DRAWING	ENGR: T HAATAJA DWN: T HAATAJA	C REV	
		SHT. 1 OF 1	

DIMENSIONS IN INCHES
THIRD ANGLE PROJECTION