

4

3

2

1

- 1.0 GENERAL NOTES  
 1.1 ALL METRIC DIMENSIONS ARE IN BRACKETS [X.X]  
 1.2 FOR PATENT INFO: <https://www.cs-pat.com>
- 2.0 DESIGN NOTES  
 2.1 ANY HAZARDS OR OBSTRUCTIONS TO THE CLIMBING FACILITY AND SAFETY CLIMB MUST BE IDENTIFIED PRIOR TO INSTALLING THE APPURTENANCE. ADDITIONAL PRODUCTS MAY BE REQUIRED TO MAINTAIN THE INTEGRITY OF THE SAFETY CLIMB. DURING INSTALLATION, TEMPORARY AND/OR PERMANENT PRECAUTIONARY MEASURES SHOULD BE TAKEN TO PRESERVE THE CLIMBING FACILITY AND/OR SAFETY CLIMB.  
 2.2 FITS MONOPOLES 15" TO 50" OD.  
 3.0 MANUFACTURING/SPECIAL REQUIREMENTS  
 3.1 TIGHTEN ALL BOLTS SECURING FLAT PLATES BY THE TURN-OF-NUT METHOD. TIGHTEN ALL U-BOLTS USING TURN-OF-NUT METHOD WITH ATTENTION TO LEAVE EQUAL DISTANCE AND EQUAL FORCE ON EACH LEG OF THE U-BOLT.  
 4.0 TEST  
 5.0 PACKAGING  
 5.1 PACKAGING SHALL MEET COMMSCOPE REQUIREMENTS PER DOCUMENT IS-PL-3005.  
 5.2 PRINTED DOCUMENT TO BE PLACED INSIDE POLYBAG AND THEN IN SHIPPING CONTAINER.  
 5.3 EXTRA HARDWARE MAY BE SUPPLIED, BAGGED AND SHIPPED.

REVISIONS			
REV.	DESCRIPTION	DATE	APPROVED
A	INITIAL RELEASE	JL1183 07MAY24	CB1094 40194988CMO

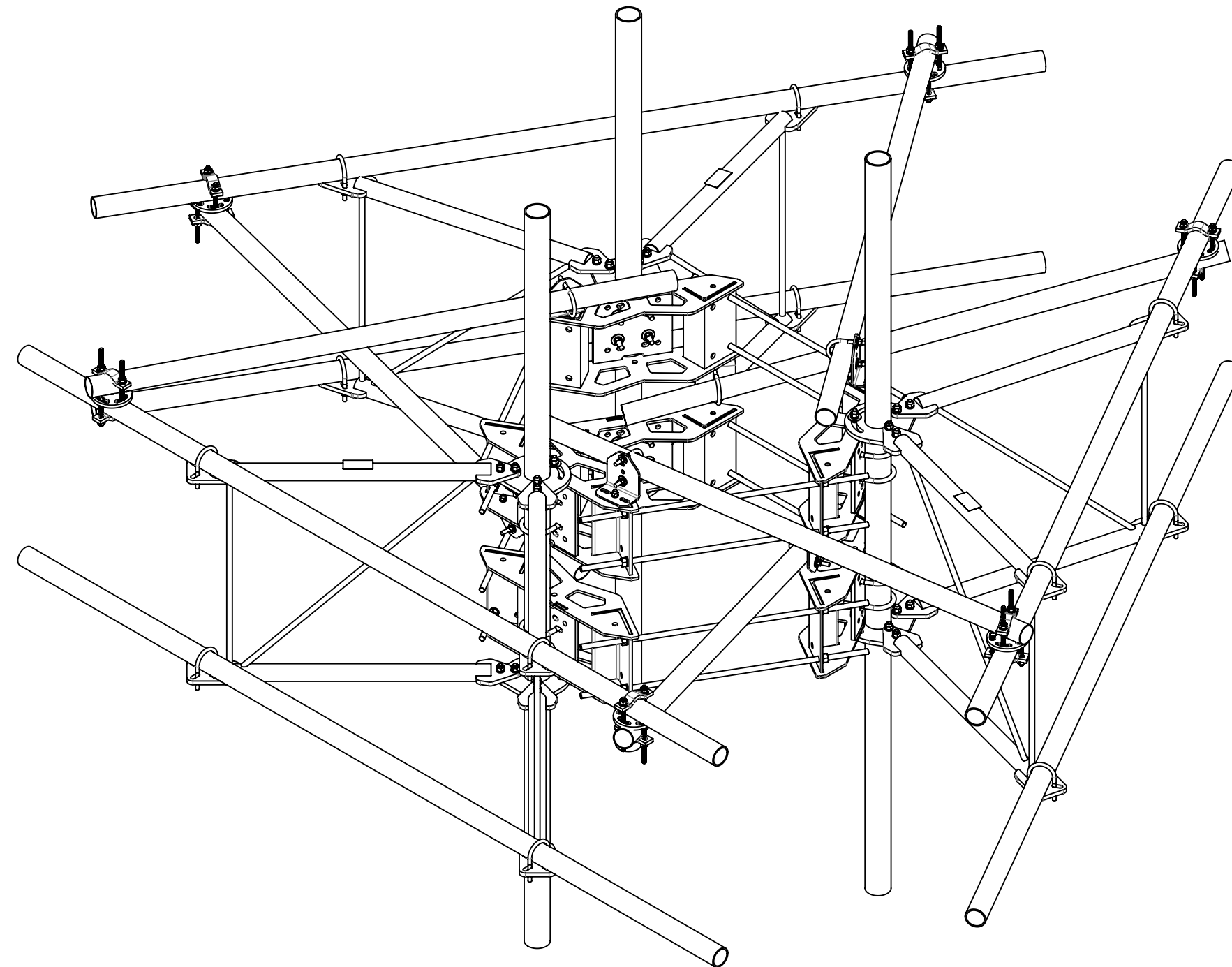

<b>COMMSCOPE, INC. OF NORTH CAROLINA</b>																	
TOLERANCES						SAP MATERIAL MASTER											
0 PLACE X[X] ± 0.25[6.3]		2 PLACE .XX[X] ± 0.06[1.5]		<b>MCG22RHDX-11MB</b>													
1 PLACE .X[X] ± 0.12[3.0]		ANGLES ± 2°															
FINISH						MATERIAL											
						<b>MP,SF,11'FP,NOAP</b>											
						SCALE		DOCUMENT NO.									
						<b>1:20</b>		<b>MCG22RHDX-11MB</b>									
						SIZE		MODEL		DRAWING			SHEET 1 OF 3				
						<b>C</b>		Auth Group INSL		VERSION STATUS REVISION		VERSION STATUS REVISION					
						00		RE		A		00		RE		A	

DENSITY		lbs/in³
MASS	1626.00	lbs
VOLUME	7521.93	in³
SURFACE AREA	59449.72	in²
HEIGHT	120"	
LENGTH	132"	
WIDTH	84"	

D

C

B

A

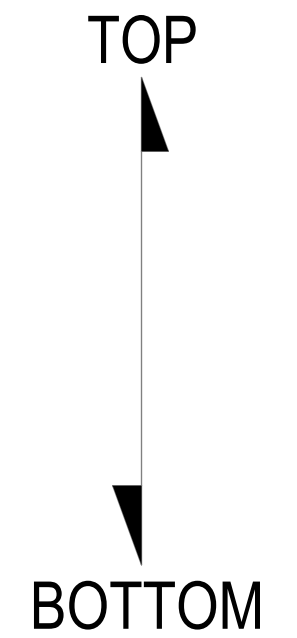
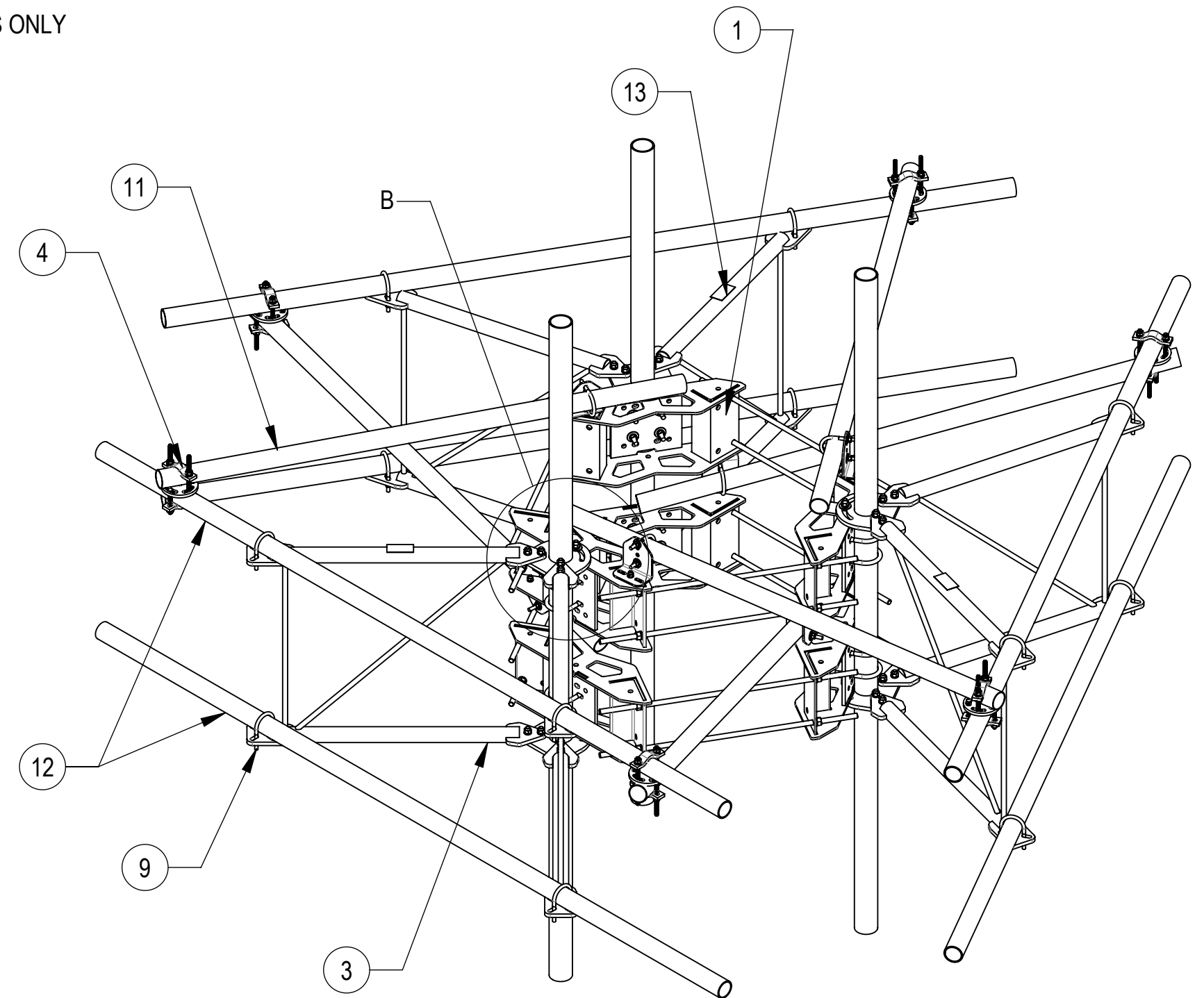
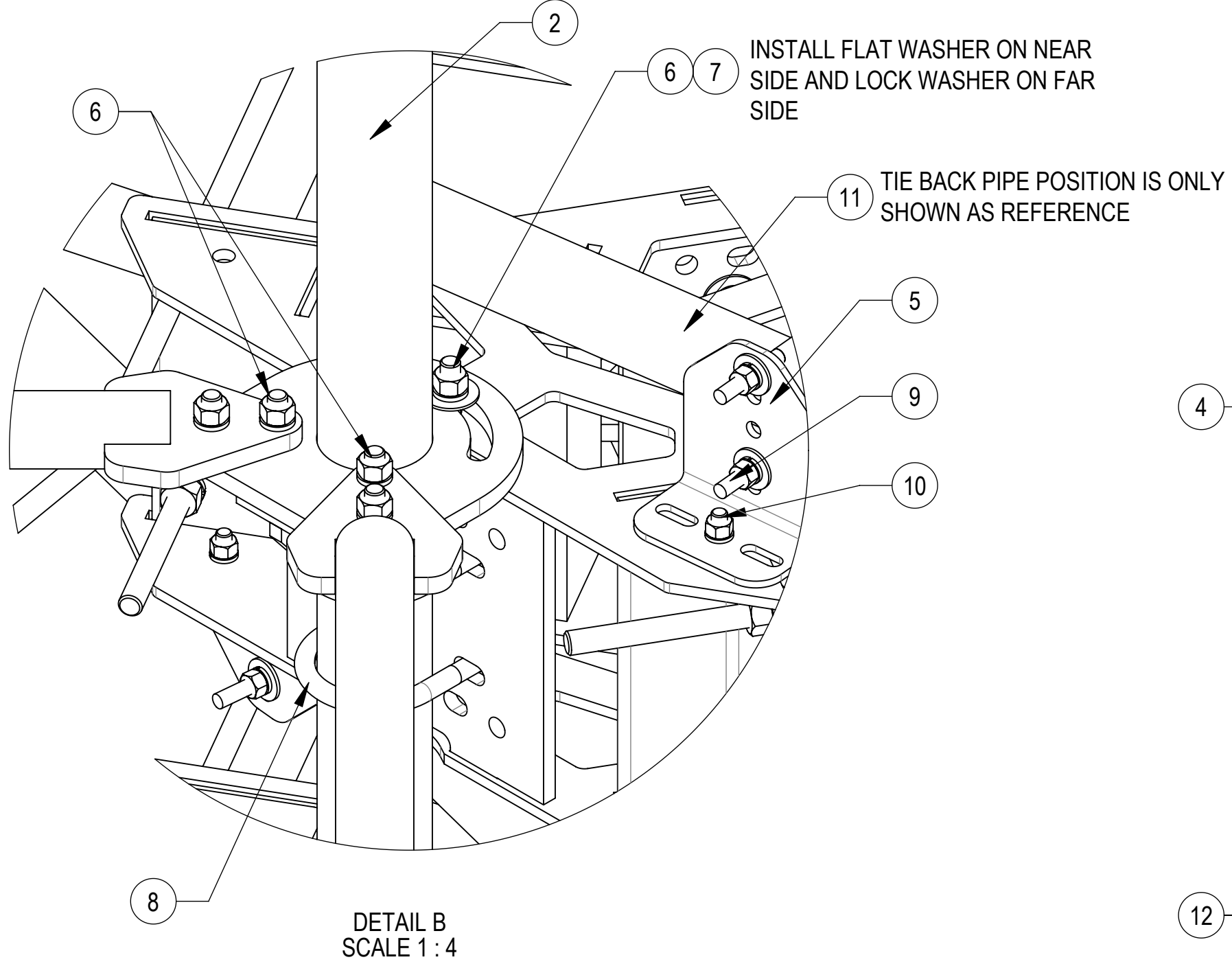

COMPONENT PART NUMBERS PROVIDED FOR ASSEMBLY PURPOSES;  
INDIVIDUAL COMPONENTS MAY BE SHIPPED AS PARTS WITHIN AN INCLUDED KIT.

ITEM	PART NO.	DESCRIPTION	QTY.	WEIGHT	NOTE NO.
1	MC-RM1550-3	15" - 50" OD RINGMOUNT	2	229.90 LBS	
2	SFG2204	WELDMENT, BACK VERTICAL ARM MOUNT	3	36.96 LBS	
3	SFG2278	ARM, STANDOFF - SFG22	6	40.92 LBS	
4	XP-R	CROSSOVER PLATE, ROUND, UP TO 3.5" OD	6	6.20 LBS	
5	XAU01	ANGLE, CROSSOVER, 1.9-3.5" X 1.9-3.5" OD	6	2.98 LBS	
6	GB-05225	5/8" X 2-1/4" GALV BOLT KIT	30	0.28 LBS	
7	GWF-05	5/8" GALV FLAT WASHER, 1.7OD	6	0.06 LBS	
8	GUB-53560	5/8" X 3-5/8" X 6" GALV U-BOLT	12	1.30 LBS	
9	GUB-4352	1/2" X 3" X 5-1/4" GALV U-BOLT	18	0.71 LBS	
10	GB-04145	1/2" X 1-1/2" GALV BOLT KIT	6	0.13 LBS	
11	MT546084120	2.88" OD X 84" LONG PIPE	6	24.81 LBS	
12	MT546132	2.875" O.D. X 132" PIPE	6	62.64 LBS	
13	SFG2295	LABEL, SFG22RHD	3	0.04 LBS	

**ALLOWABLE TIEBACK ANGLE**  
±15 DEGREES VERTICAL  
±25 DEGREES HORIZONTAL

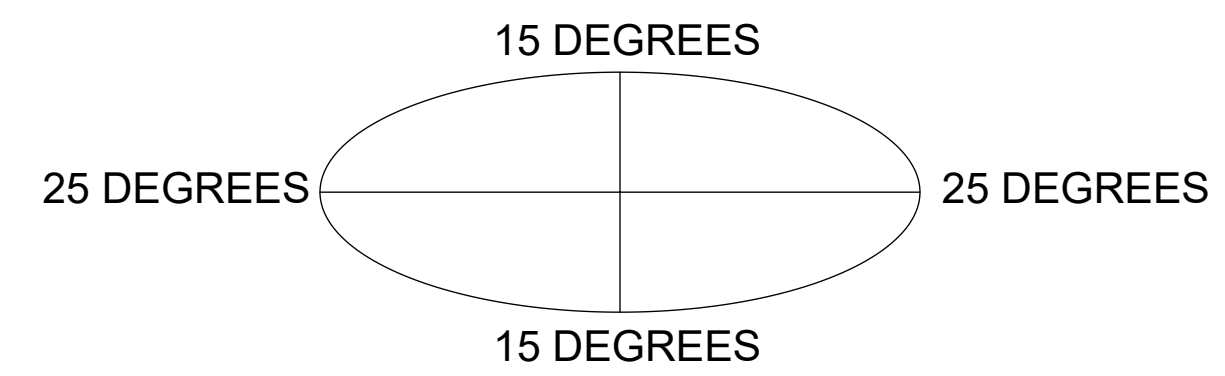

COMMSCOPE, INC. OF NORTH CAROLINA				
TITLE MP,SF,11'FP,NOAP				
SIZE C	SCALE 1:20	DOCUMENT NO. MCG22RHD-11MB		
DRAWING		VERSION	STATUS	REVISION
		00	RE	A
				SHEET 2 OF 3

4

3

2

1

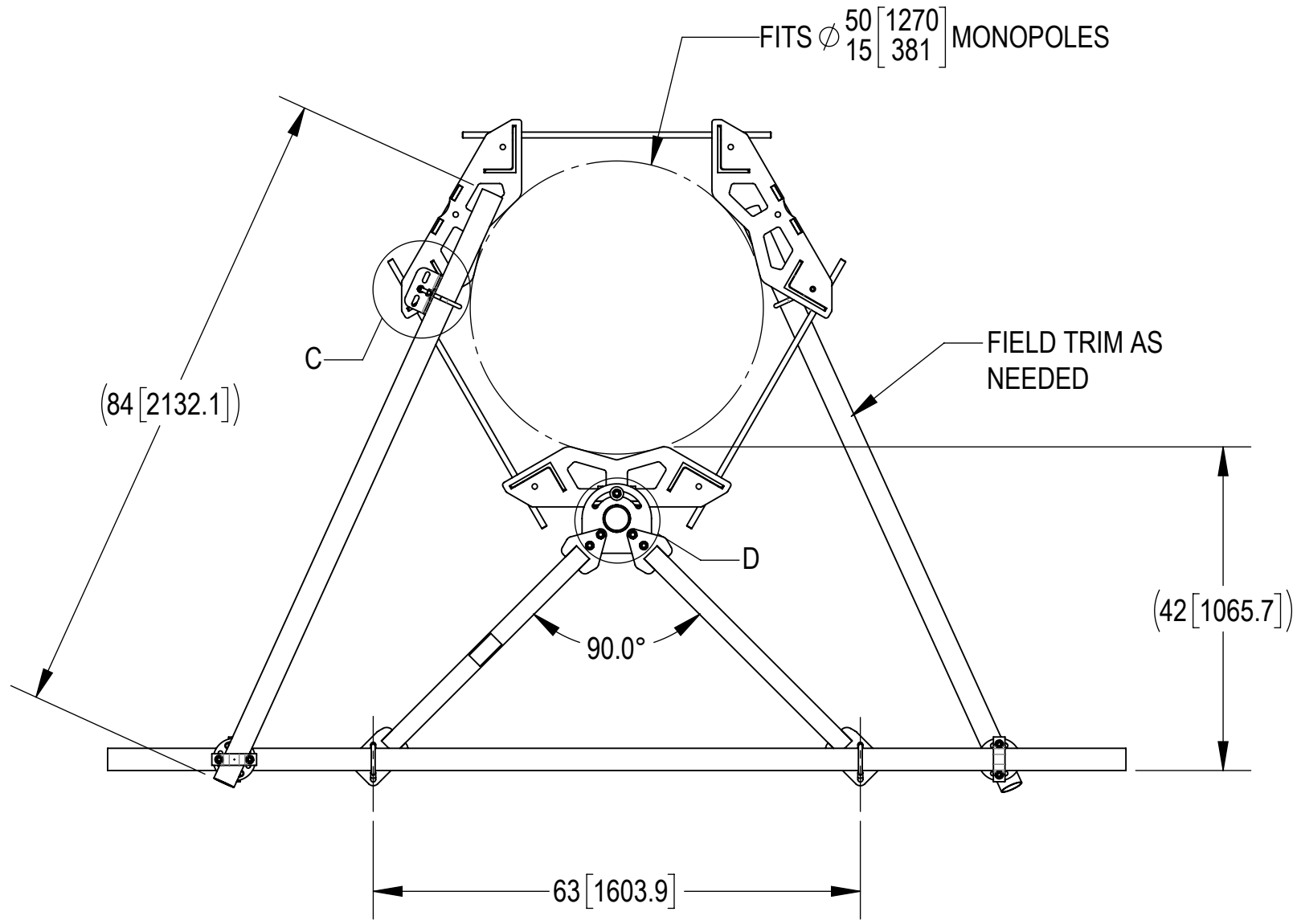

### ALLOWABLE TIEBACK ANGLE

± 15 DEGREES VERTICAL  
± 25 DEGREES HORIZONTAL

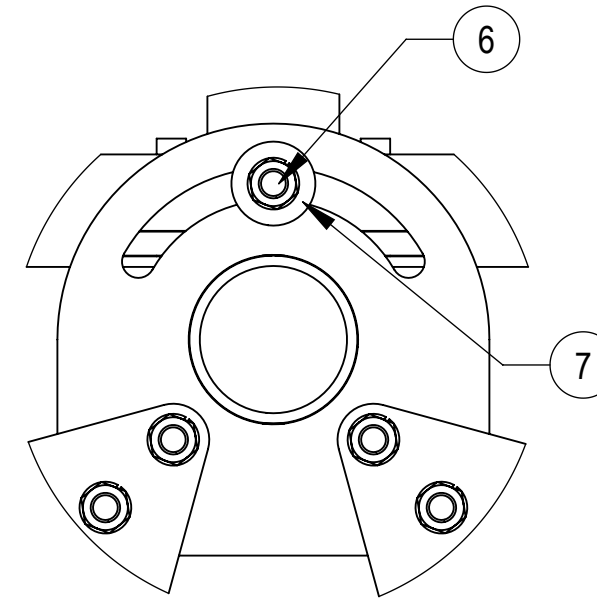
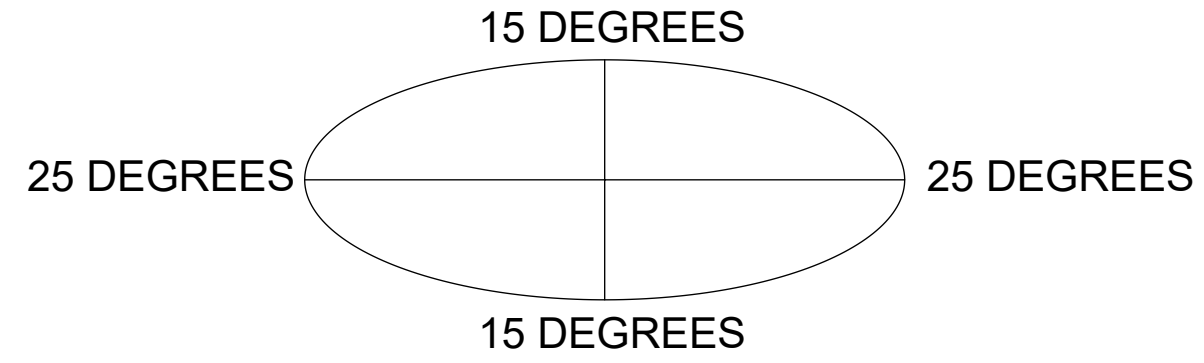

DETAIL D  
SCALE 1 : 4

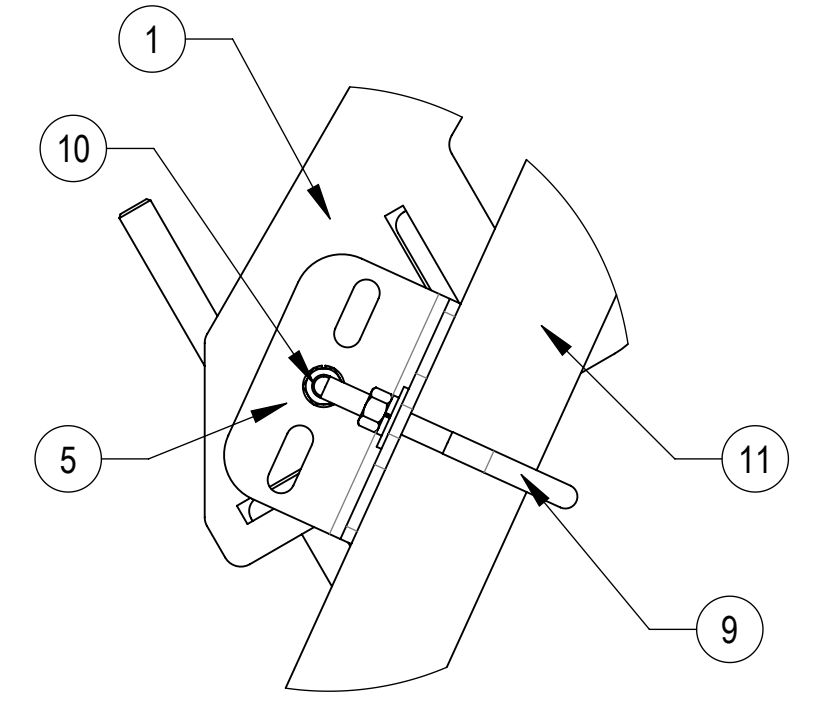

DETAIL C  
SCALE 1 : 4

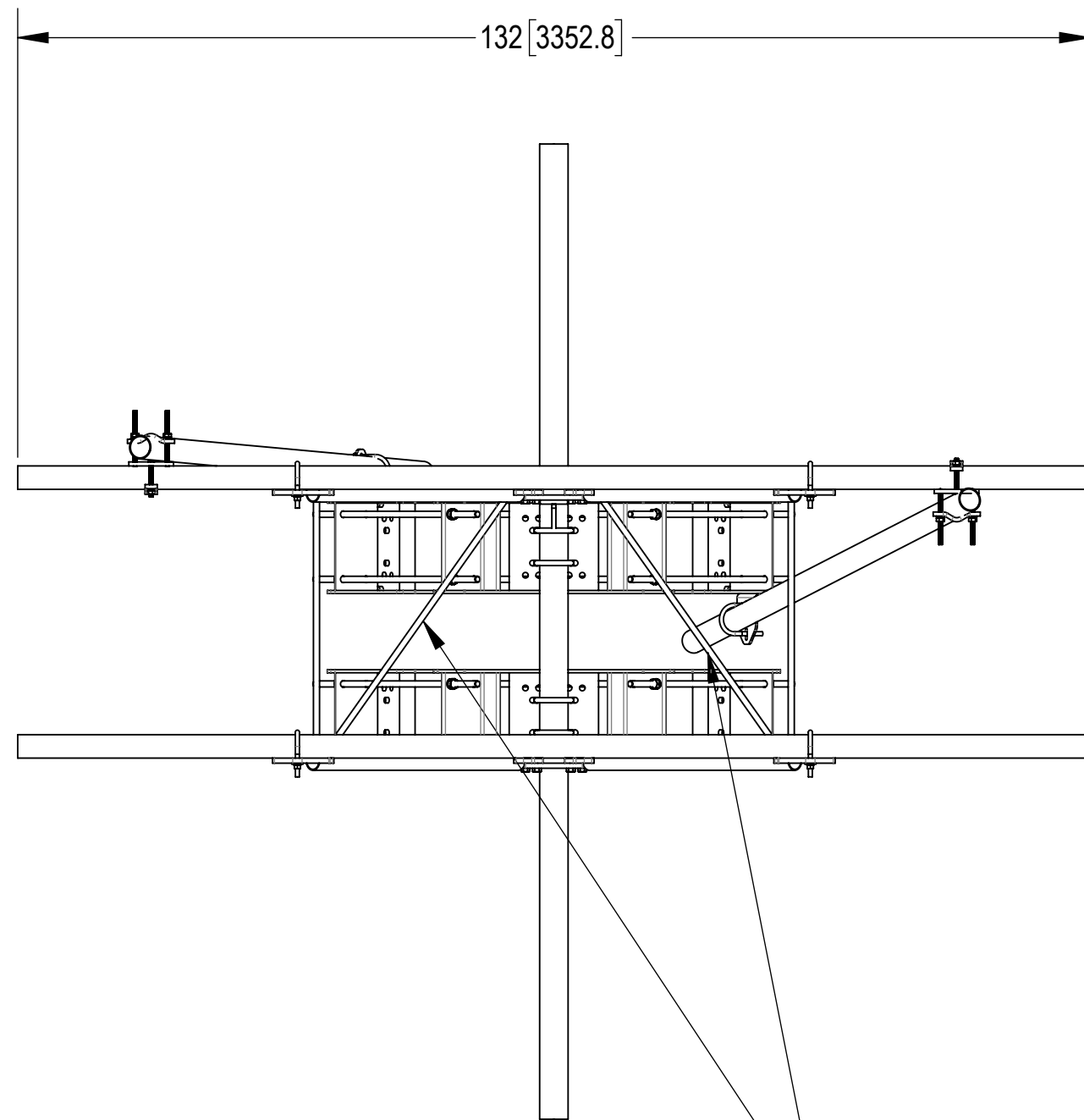

TOP  
BOTTOM

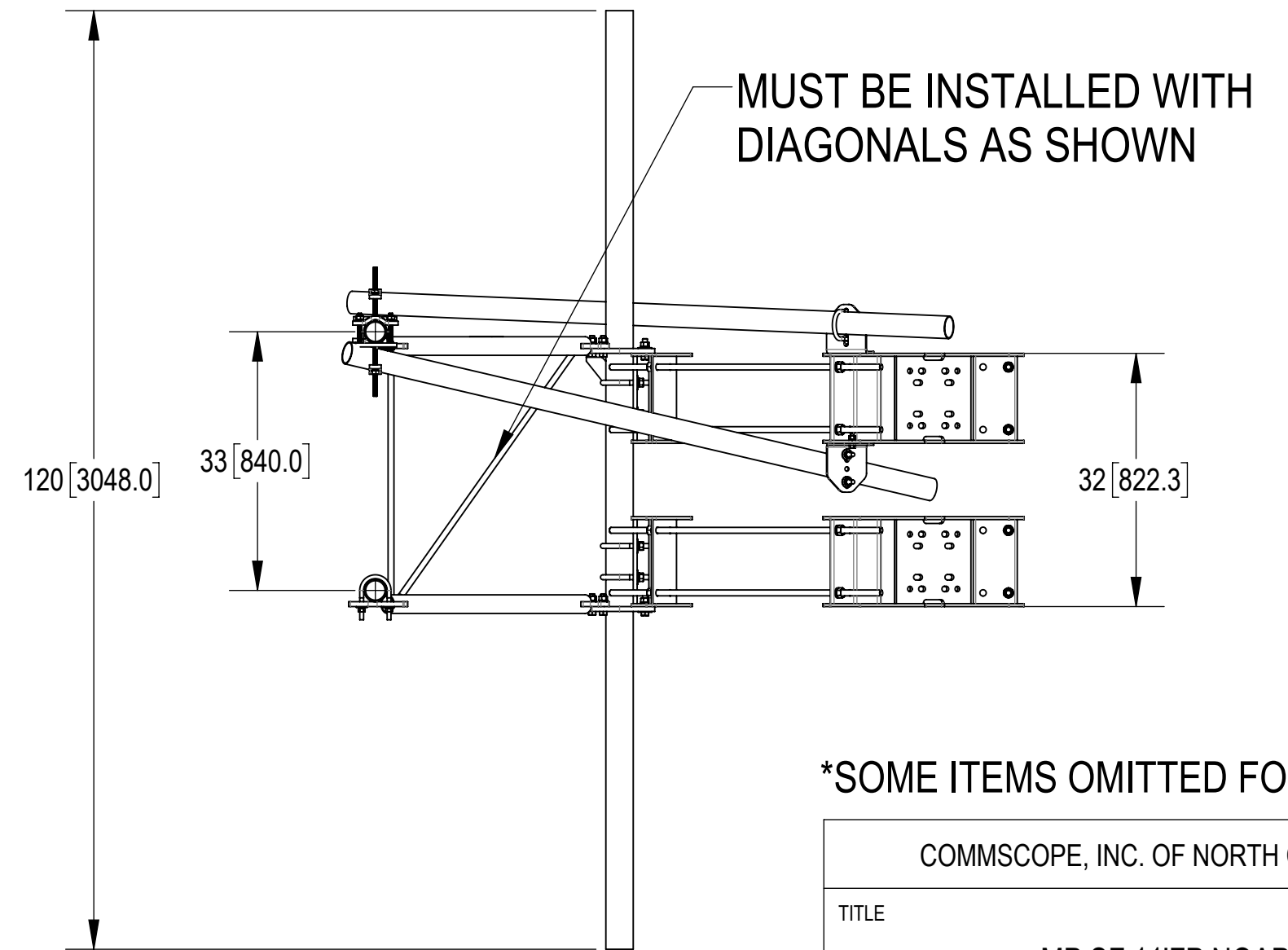

\*SOME ITEMS OMITTED FOR CLARITY\*

COMMSCOPE, INC. OF NORTH CAROLINA				
TITLE MP,SF,11'FP,NOAP				
SIZE C	SCALE 1:20	DOCUMENT NO. MCG22RHDx-11MB		
		DRAWING		SHEET
		VERSION	STATUS	REVISION
		00	RE	A
				3 OF 3

4

3

2

1