

4

3

2

1

1.0 GENERAL NOTES

- 1.1 ALL METRIC DIMENSIONS ARE IN BRACKETS [X.X]
- 1.2 FOR PATENT INFO: <https://www.cs-pat.com>

2.0 DESIGN NOTES

- 2.1 ANY HAZARDS OR OBSTRUCTIONS TO THE CLIMBING FACILITY AND SAFETY CLIMB MUST BE IDENTIFIED PRIOR TO INSTALLING THE APPURTENANCE. ADDITIONAL PRODUCTS MAY BE REQUIRED TO MAINTAIN THE INTEGRITY OF THE SAFETY CLIMB. DURING INSTALLATION, TEMPORARY AND/OR PERMANENT PRECAUTIONARY MEASURES SHOULD BE TAKEN TO PRESERVE THE CLIMBING FACILITY AND/OR SAFETY CLIMB.
- 2.2 FITS MONOPOLES 15" TO 50" OD.
- 3.0 MANUFACTURING/SPECIAL REQUIREMENTS
 - 3.1 TIGHTEN ALL BOLTS SECURING FLAT PLATES BY THE TURN-OF-NUT METHOD. TIGHTEN ALL U-BOLTS USING TURN-OF-NUT METHOD WITH ATTENTION TO LEAVE EQUAL DISTANCE AND EQUAL FORCE ON EACH LEG OF THE U-BOLT.

4.0 TEST

5.0 PACKAGING

- 5.1 PACKAGING SHALL MEET COMMSCOPE REQUIREMENTS PER DOCUMENT IS-PL-3005.
- 5.2 PRINTED DOCUMENT TO BE PLACED INSIDE POLYBAG AND THEN IN SHIPPING CONTAINER.
- 5.3 EXTRA HARDWARE MAY BE SUPPLIED, BAGGED AND SHIPPED.

| REVISIONS | | | |
|-----------|-----------------|-------------------|-----------------------|
| REV. | DESCRIPTION | DATE | APPROVED |
| A | INITIAL RELEASE | JL1183 07MAY24 | CB1094 40194988CMO |

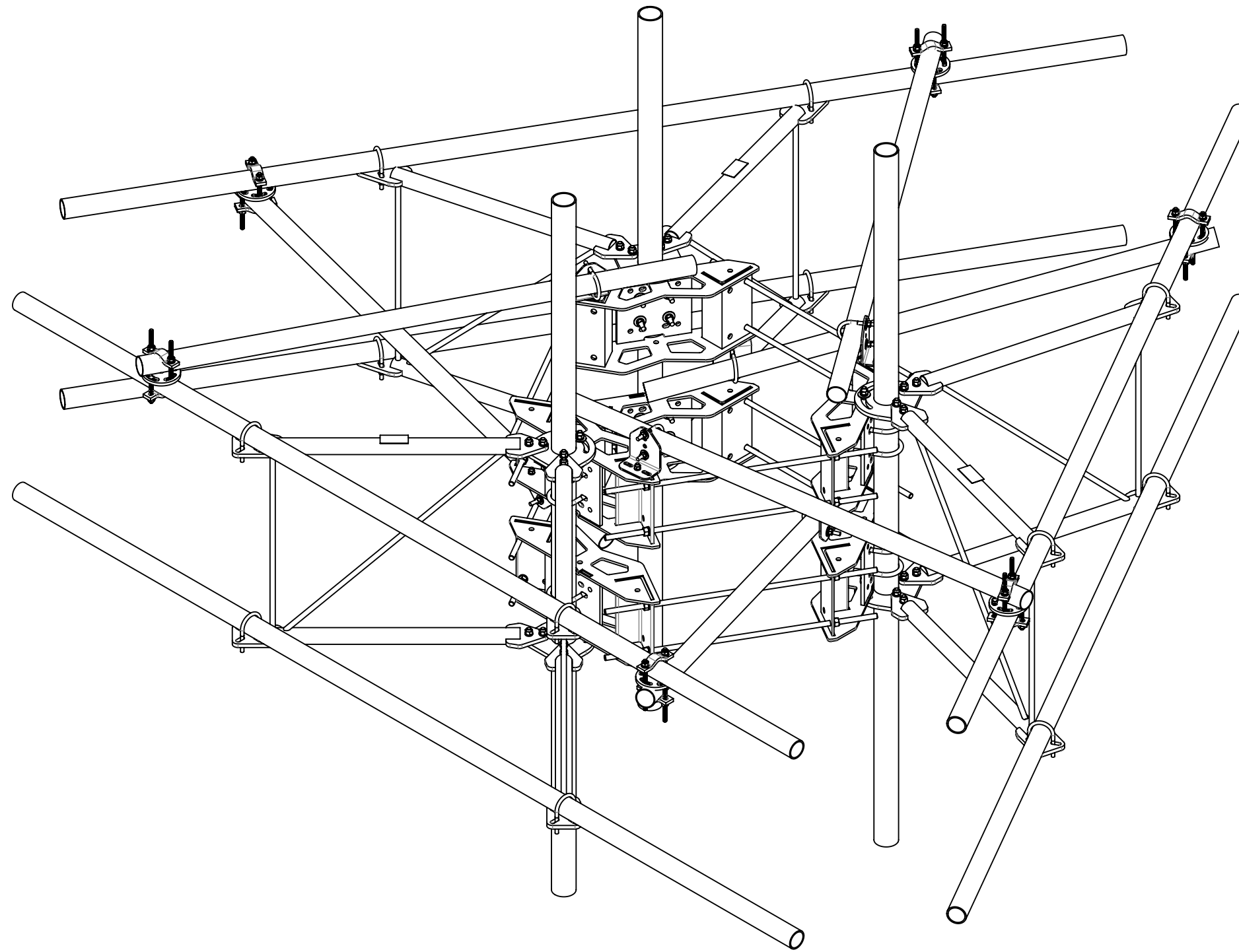

COMMSCOPE, INC. OF NORTH CAROLINA

| TOLERANCES | | SAP MATERIAL MASTER | | | | | | | |
|---|-------------------|---------------------|--------------------|--------------|----------|---------|--------|----------|--------|
| 0 PLACE | X[X] ± 0.25[6.3] | 2 PLACE | .XX[X] ± 0.06[1.5] | | | | | | |
| 1 PLACE | .X[X] ± 0.12[3.0] | ANGLES | ± 2° | | | | | | |
| FINISH | | MATERIAL | | | | | | | |
| | | MCG22RHDX-13MB | | | | | | | |
| UNLESS OTHERWISE SPECIFIED DIMENSIONS ARE IN INCHES INTERPRET PER ANSI Y 14.5M-1994 | NAME | DATE | TITLE | | | | | | |
| | CE JL1183 | 07MAY24 | MP,SF,13'FP,NOAP | | | | | | |
| | RW JL1183 | 05/16/2024 | | | | | | | |
| | AD CB1094 | 05/22/2024 | | | | | | | |
| | RE JL1183 | 05/23/2024 | SCALE | DOCUMENT NO. | | | | | |
| ECN 40194988CMO | | 1:20 | MCG22RHDX-13MB | | | | | | |
| SIZE | Auth Group | INSL | MODEL | DRAWING | | | SHEET | | |
| C | | | VERSION | STATUS | REVISION | VERSION | STATUS | REVISION | 1 OF 3 |
| | | | 00 | RE | A | 00 | RE | A | |

| | | |
|--------------|----------|---------|
| DENSITY | | lbs/in³ |
| MASS | 1703.67 | lbs |
| VOLUME | 7783.28 | in³ |
| SURFACE AREA | 61827.72 | in² |
| HEIGHT | 120" | |
| LENGTH | 156" | |
| WIDTH | 84" | |

4

3

2

1

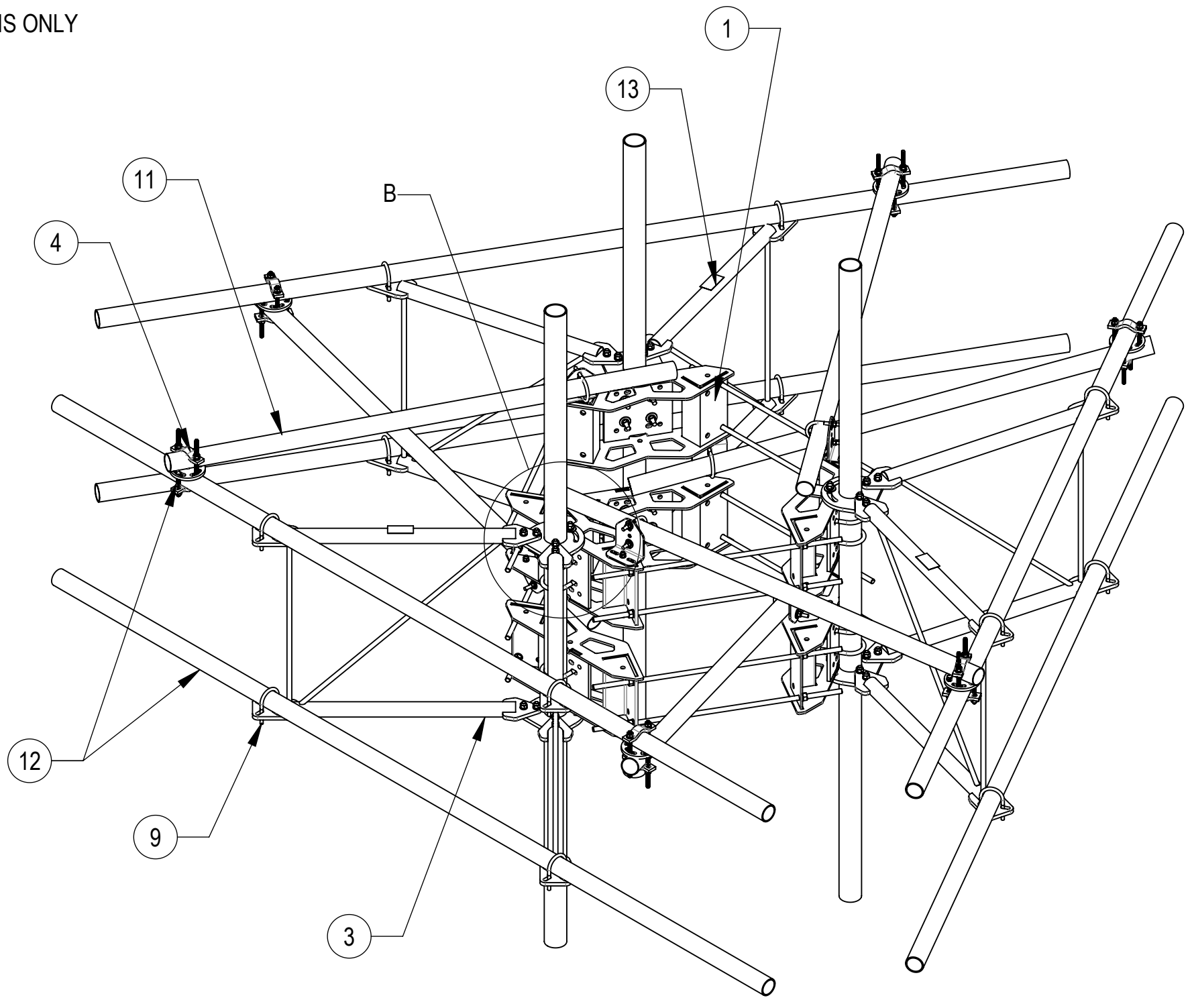
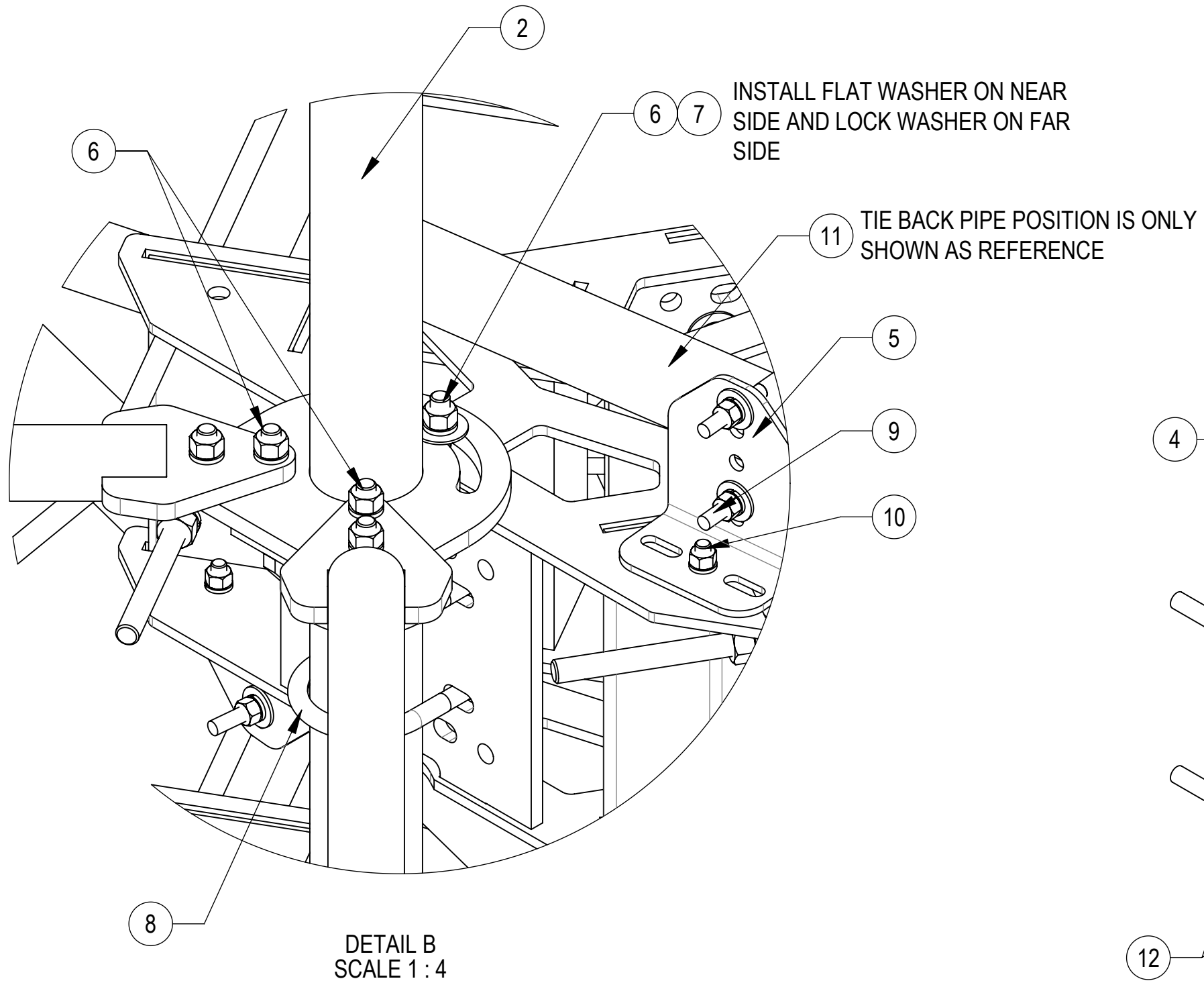

COMPONENT PART NUMBERS PROVIDED FOR ASSEMBLY PURPOSES;
INDIVIDUAL COMPONENTS MAY BE SHIPPED AS PARTS WITHIN AN INCLUDED KIT.

| ITEM | PART NO. | DESCRIPTION | QTY. | WEIGHT | NOTE NO. |
|------|-------------|--|------|-----------|----------|
| 1 | MC-RM1550-3 | 15" - 50" OD RINGMOUNT | 2 | 0.00 LBS | |
| 2 | SFG2204 | WELDMENT, BACK VERTICAL ARM MOUNT | 3 | 36.96 LBS | |
| 3 | SFG2278 | ARM, STANDOFF - SFG22 | 6 | 40.92 LBS | |
| 4 | XP-R | CROSSOVER PLATE, ROUND, UP TO 3.5" OD | 6 | 6.20 LBS | |
| 5 | XAU01 | ANGLE, CROSSOVER, 1.9-3.5" X 1.9-3.5" OD | 6 | 2.98 LBS | |
| 6 | GB-05225 | 5/8" X 2-1/4" GALV BOLT KIT | 30 | 0.28 LBS | |
| 7 | GWF-05 | 5/8" GALV FLAT WASHER, 1.7OD | 6 | 0.06 LBS | |
| 8 | GUB-53560 | 5/8" X 3-5/8" X 6" GALV U-BOLT | 12 | 1.30 LBS | |
| 9 | GUB-4352 | 1/2" X 3" X 5-1/4" GALV U-BOLT | 18 | 0.71 LBS | |
| 10 | GB-04145 | 1/2" X 1-1/2" GALV BOLT KIT | 6 | 0.13 LBS | |
| 11 | MT546084120 | 2.88" OD X 84" LONG PIPE | 6 | 24.81 LBS | |
| 12 | MT546156 | 2.875" O.D. X 156" PIPE | 6 | 75.58 LBS | |
| 13 | SFG2295 | LABEL, SFG22RHD | 3 | 0.04 LBS | |

ALLOWABLE TIEBACK ANGLE

±15 DEGREES VERTICAL
±25 DEGREES HORIZONTAL

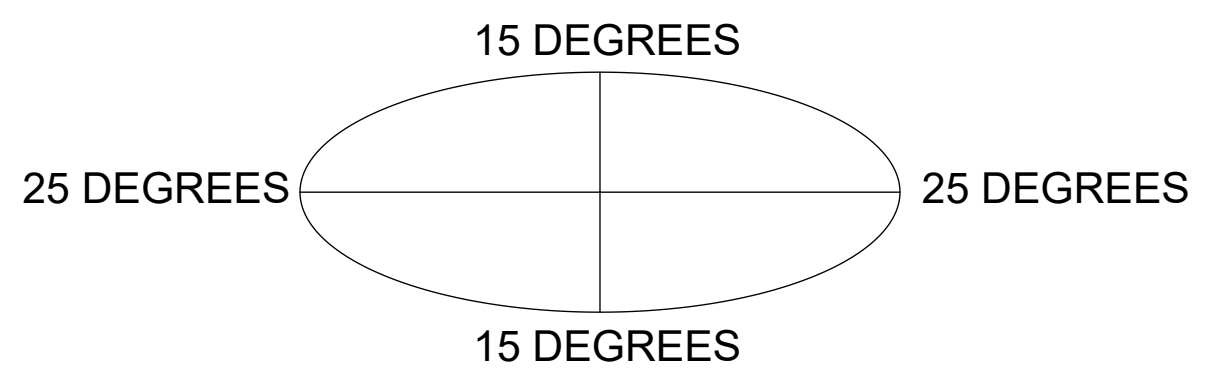

| | | | | |
|-----------------------------------|---------------|-------------------------------|--------|-----------------|
| COMMSCOPE, INC. OF NORTH CAROLINA | | | | |
| TITLE MP,SF,13'FP,NOAP | | | | |
| SIZE C | SCALE 1:20 | DOCUMENT NO. MCG22RHD-13MB | | |
| DRAWING | | VERSION | STATUS | REVISION |
| | | 00 | RE | A |
| | | | | SHEET 2 OF 3 |

4

3

2

1

ALLOWABLE TIEBACK ANGLE

±15 DEGREES VERTICAL
±25 DEGREES HORIZONTAL

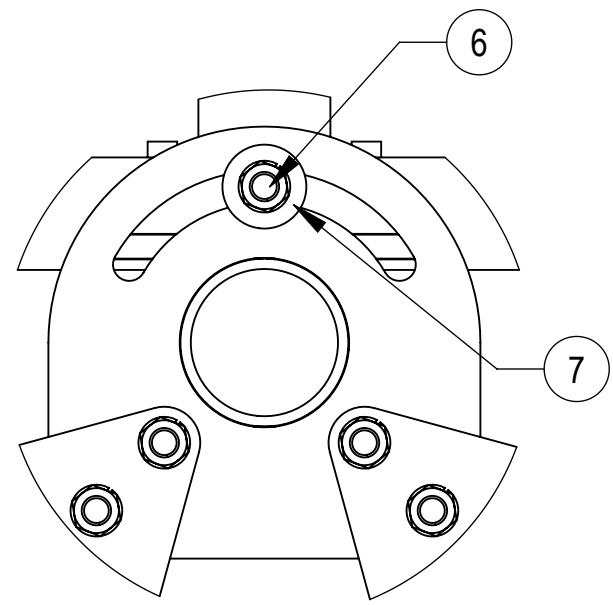
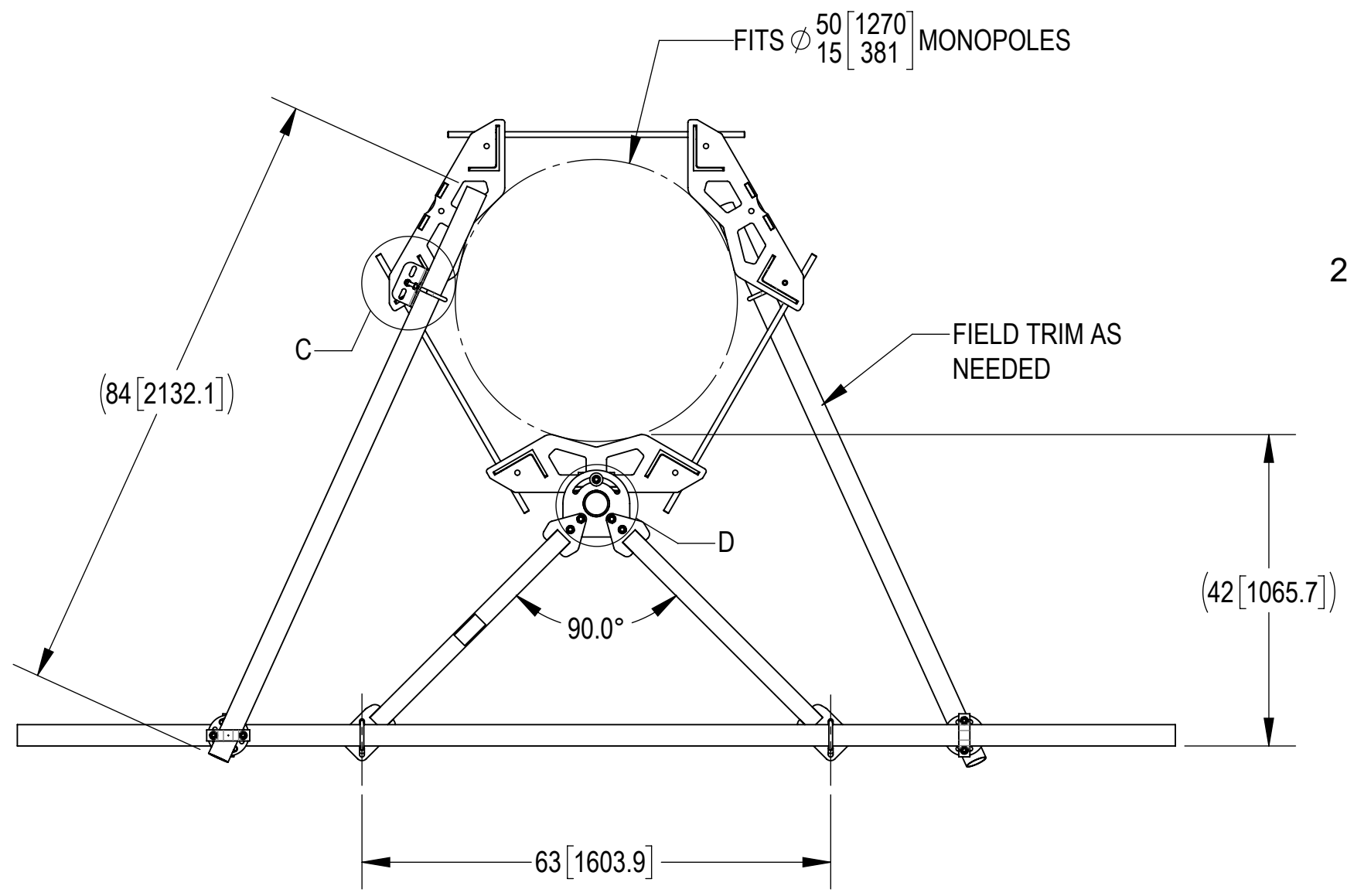
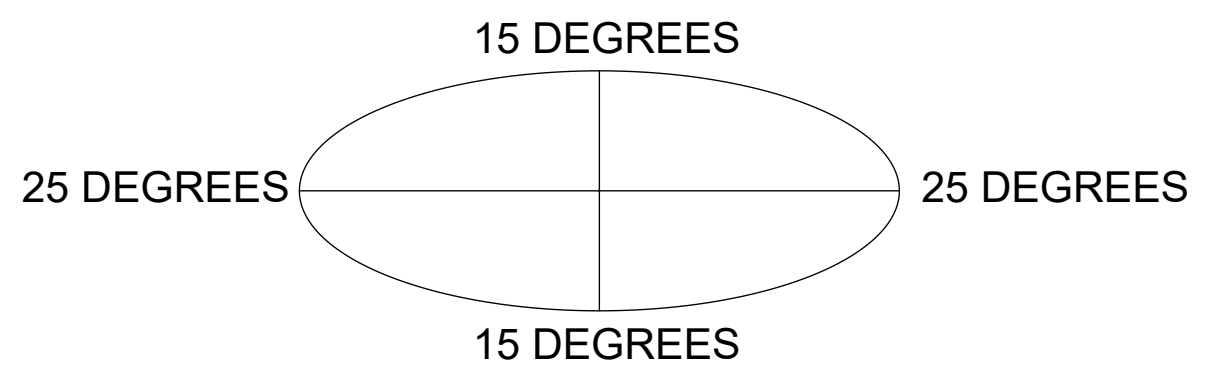

DETAIL D
SCALE 1:4

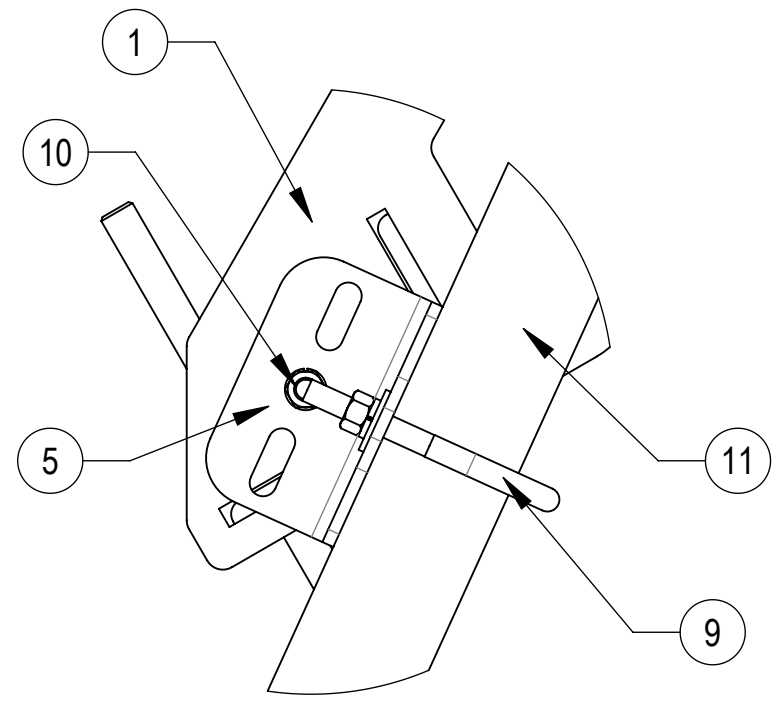

DETAIL C
SCALE 1:4

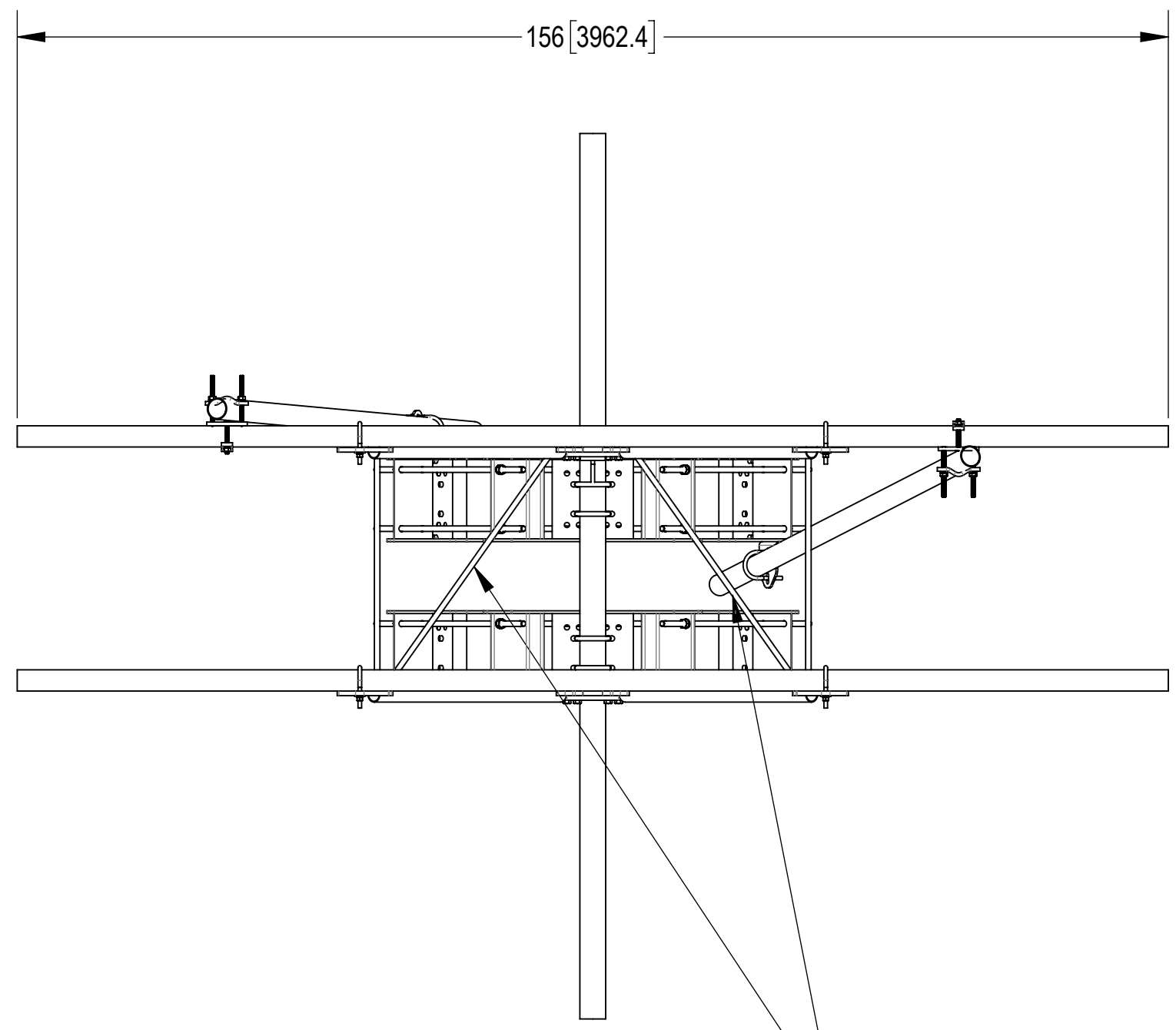

TOP
BOTTOM

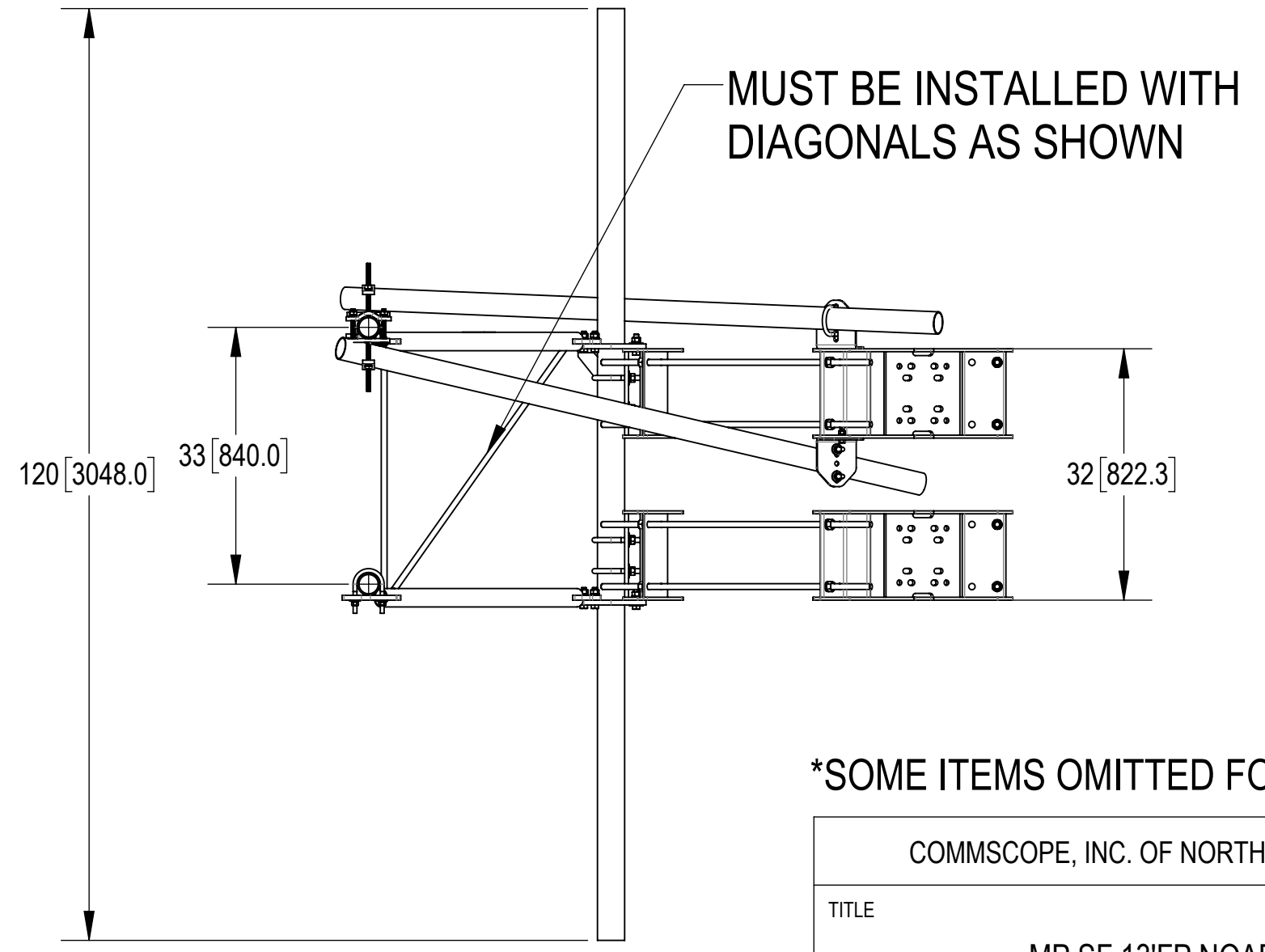

MUST BE INSTALLED WITH
DIAGNALS AS SHOWN

SOME ITEMS OMITTED FOR CLARITY

| | | | | |
|-----------------------------------|---------------|--------------------------------|--------|-----------------|
| COMMSCOPE, INC. OF NORTH CAROLINA | | | | |
| TITLE MP,SF,13'FP,NOAP | | | | |
| SIZE C | SCALE 1:20 | DOCUMENT NO. MCG22RHDx-13MB | | |
| | | DRAWING | | SHEET |
| | | VERSION | STATUS | REVISION |
| | | 00 | RE | A |
| | | | | SHEET 3 OF 3 |

4

3

2

1

D

D

C

C

B

B

A

A