

4

3

2

1

- 1.0 GENERAL NOTES
 - 1.1 ALL METRIC DIMENSIONS ARE IN BRACKETS [X.X]
 - 1.2 FOR PATENT INFO: <https://www.cs-pat.com>

- 2.0 DESIGN NOTES
 - 2.1 ANY HAZARDS OR OBSTRUCTIONS TO THE CLIMBING FACILITY AND SAFETY CLIMB MUST BE IDENTIFIED PRIOR TO INSTALLING THE APPURTENANCE. ADDITIONAL PRODUCTS MAY BE REQUIRED TO MAINTAIN THE INTEGRITY OF THE SAFETY CLIMB. DURING INSTALLATION, TEMPORARY AND/OR PERMANENT PRECAUTIONARY MEASURES SHOULD BE TAKEN TO PRESERVE THE CLIMBING FACILITY AND/OR SAFETY CLIMB.

D **2.2** FITS MONOPOLES 45" TO 50" OD. MONOPOLE DIAMETER MUST BE GREATER THAN OR EQUAL TO 45" TO MEET ANTENNA TO ANTENNA CORNER SPACING OF >24".

- 3.0 MANUFACTURING/SPECIAL REQUIREMENTS
 - 3.1 TIGHTEN ALL BOLTS SECURING FLAT PLATES BY THE TURN-OF-NUT METHOD. TIGHTEN ALL U-BOLTS USING TURN-OF-NUT METHOD WITH ATTENTION TO LEAVE EQUAL DISTANCE AND EQUAL FORCE ON EACH LEG OF THE U-BOLT.

- 4.0 TEST
- 5.0 PACKAGING
 - 5.1 PACKAGING SHALL MEET COMMSCOPE REQUIREMENTS PER DOCUMENT IS-PL-3005.
 - 5.2 PRINTED DOCUMENT TO BE PLACED INSIDE POLYBAG AND THEN IN SHIPPING CONTAINER.
 - 5.3 EXTRA HARDWARE MAY BE SUPPLIED, BAGGED AND SHIPPED.

REVISIONS			
REV.	DESCRIPTION	DATE	APPROVED
A	INITIAL RELEASE	JL1183 16APR24	CB1094 40193542CMO

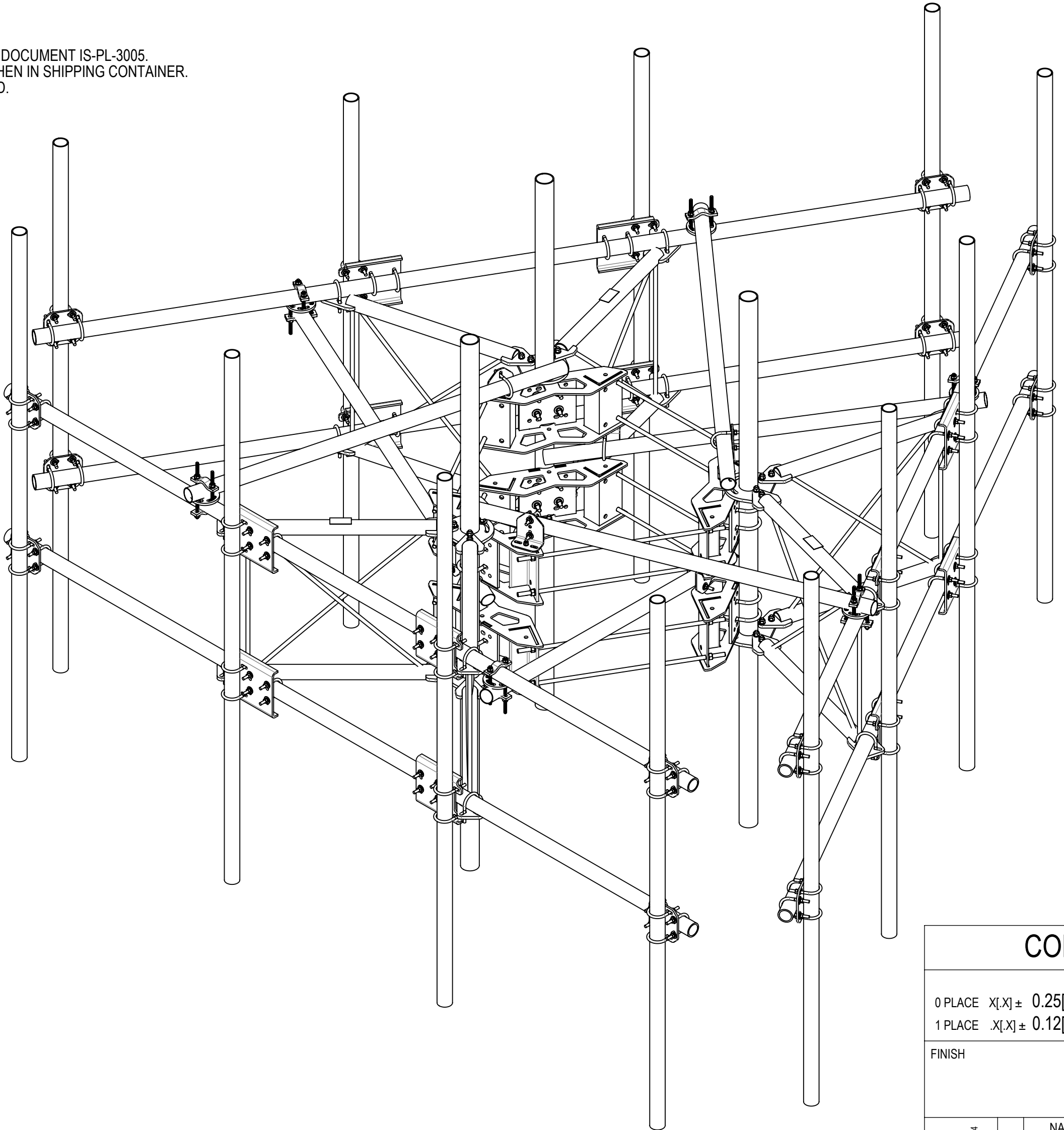

COMMSCOPE, INC. OF NORTH CAROLINA

TOLERANCES		SAP MATERIAL MASTER	
0 PLACE X[X] ± 0.25[6.3]	2 PLACE .XX[X] ± 0.06[1.5]	MCG23RHDX-15M12120	
1 PLACE X[X] ± 0.12[3.0]	ANGLES ± 2°		
FINISH		MATERIAL	

UNLESS OTHERWISE SPECIFIED DIMENSIONS ARE IN INCHES INTERPRET PER ANSI Y 14.5M-1994	NAME	DATE	TITLE
	CE JL1183	16APR24	
	RW JL1183	04/17/2024	MONO 3 SCTR FR 15' FACE,(12) 120" ANT
	AD CB1094	04/22/2024	
	RE JL1183	04/22/2024	
ECN 40193542CMO			SCALE DOCUMENT NO.
			1:20 MCG23RHDX-15M12120

DENSITY	3066.14	lbs/in ³
MASS	3066.14	lbs
VOLUME	12910.14	in ³
SURFACE AREA	99104.33	in ²
HEIGHT	120"	
LENGTH	180"	
WIDTH	84"	

C	Auth Group	INSL	MODEL		DRAWING			SHEET 1 OF 6
			VERSION	STATUS	REVISION	VERSION	STATUS	
	00	RE	A	00	RE	A		

4

3

2

1

PART NUMBERS, WEIGHTS, & EPA

TABLE 1: CONFIGURATIONS

PART NUMBER	DESCRIPTION	WEIGHT (LBS)	(EPA)A (FT ²)*	(EPA)A 1/2" ICE THICKNESS (FT ²)*	ANTENNA PIPES	INCLUDED PARTS							
						MC-RM1550-3D	MCG23HDX-HK02	MCG23RHDX-SB01	XP-2525-12	XP-2525-OFF-12	SFG2204	PB0607B12TEK0615P	SFG2398
MCG23RHDX-15M12120	MONO 3 SCTR FR 15' FACE,(12) 120" ANT	3066.15	23.84	33.85	12	1	1	1	1	1	3	1	3

* (EPA)A DOES NOT INCLUDE ANTENNA PIPES AND MOUNTING HARDWARE. IF DESIRED, ADD ANTENNA PIPE PER TABLE 2

TABLE 2: EPA OF EACH ANTENNA PIPE

ANTENNA PIPE	(EPA)A (FT ²)	(EPA)A W/ 1/2" ICE THICKNESS (FT ²)
2-7/8" X120"	2.30	3.10



NOTE:

- ANTENNA PIPES ARE CONSIDERED SEPARATELY.
- KA FACTOR OF 3-SECTOR EPA INCLUDED.
- COMBINE THE ASSOCIATED EPA VALUES IN THE TABLES ABOVE TO DETERMINE THE EPA OF A MOUNT MODEL WITH A LISTED MOUNT PIPE CONFIGURATION.
FOR EXAMPLE, MCG23RHDX-15M12120 HAS A 3-SECTOR EPA OF 23.84 FT² WITH NO ICE PLUS 12 ANTENNA PIPES WITH A 3-SECTOR EPA OF 12X2.30=27.60 FT² WITH NO ICE.
SO, THE TOTAL EPA OF 51.44 FT² FOR THE MCG23RHDX-15M12120.

COMMSCOPE, INC. OF NORTH CAROLINA

TITLE
MONO 3 SCTR FR 15' FACE,(12) 120" ANT

SIZE C	SCALE 1:24	DOCUMENT NO. MCG23RHDX-15M12120
------------------	----------------------	------------------------------------

		DRAWING			SHEET 2 OF 6
		VERSION 00	STATUS RE	REVISION A	

4

3

2

1

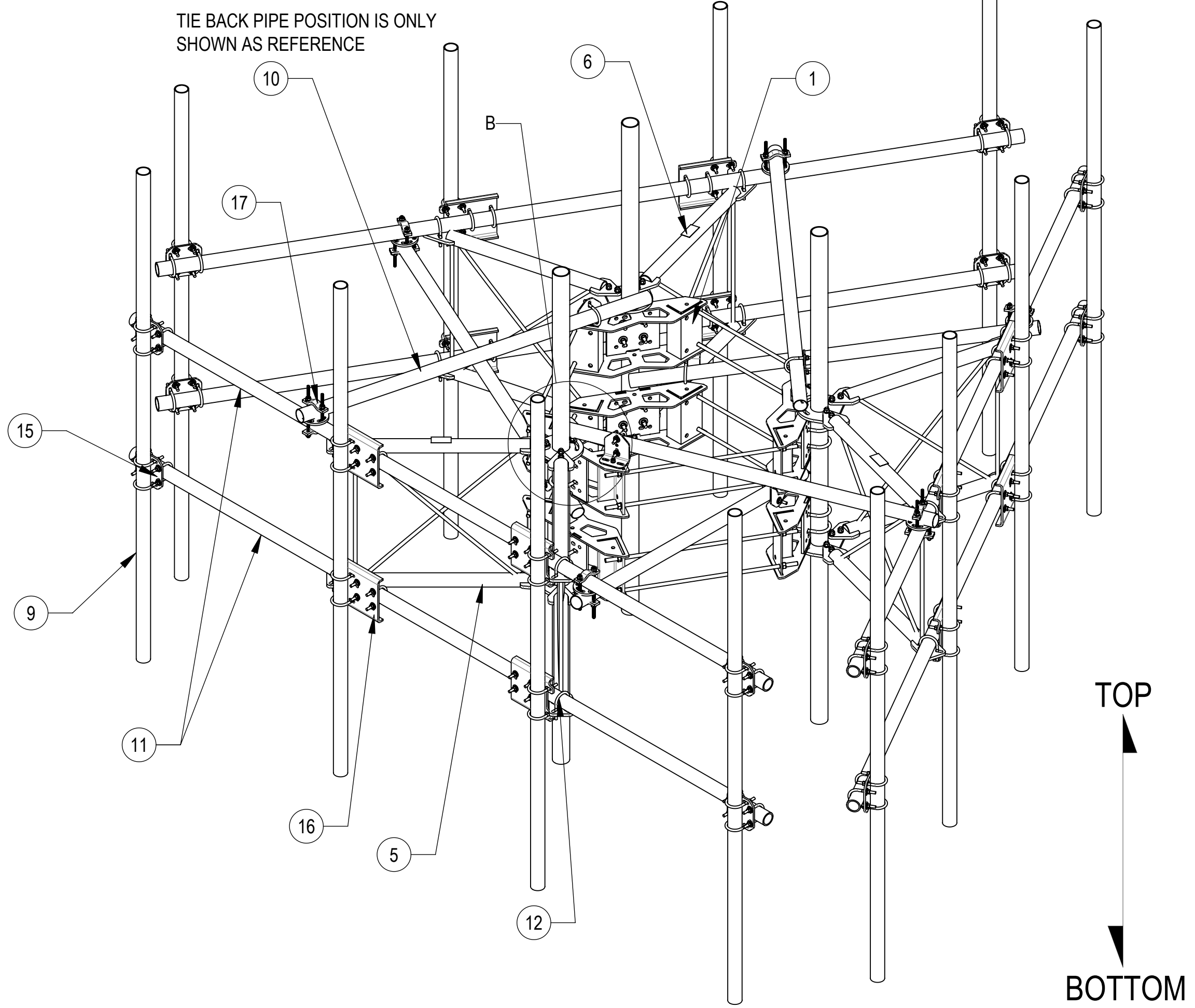
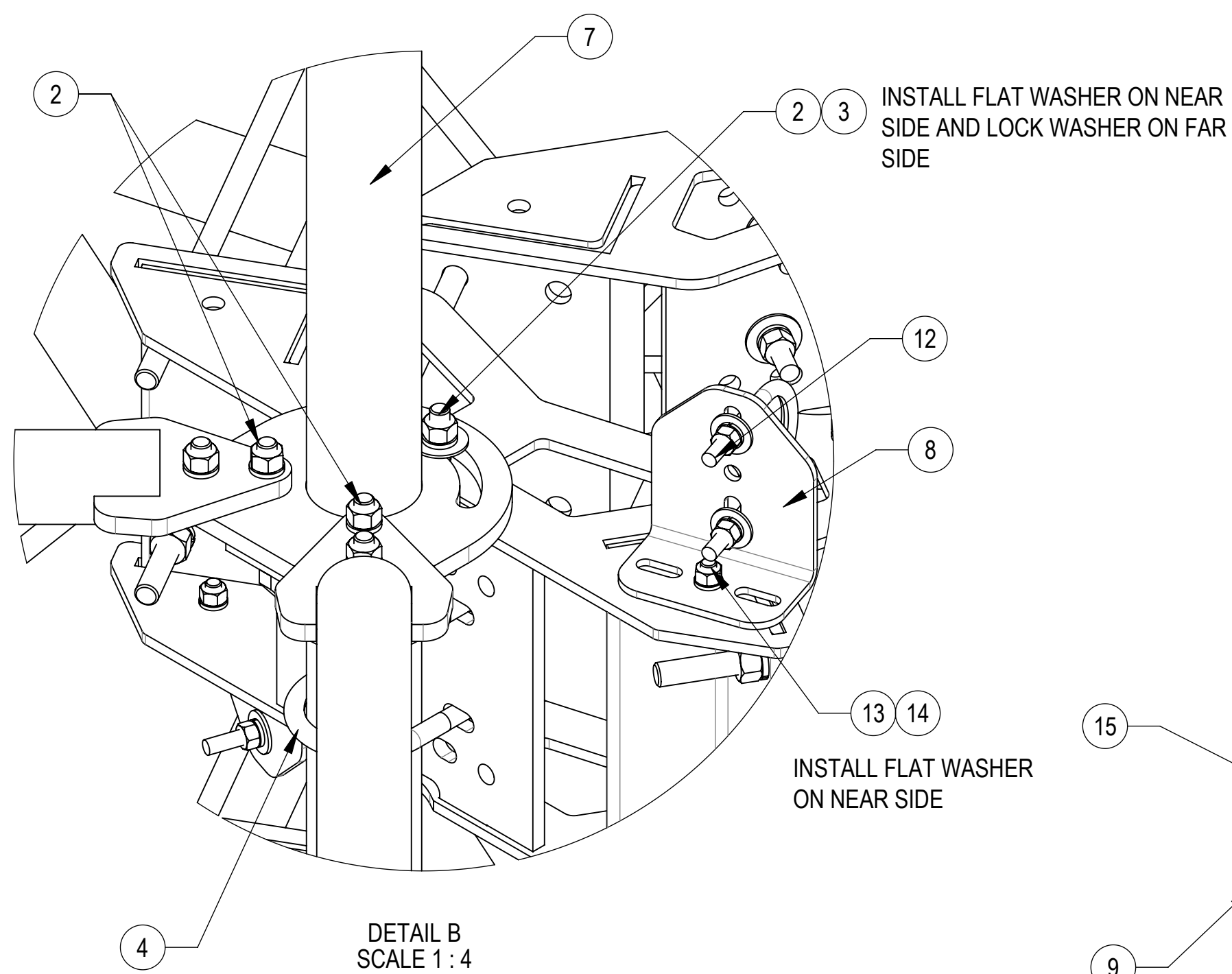

COMPONENT PART NUMBERS PROVIDED FOR ASSEMBLY PURPOSES;
INDIVIDUAL COMPONENTS MAY BE SHIPPED AS PARTS WITHIN AN INCLUDED KIT.

ITEM	PART NO.	DESCRIPTION	QTY.	WEIGHT	NOTE NO.
1	MC-RM1550-3	15" - 50" OD RINGMOUNT	2	0.00 LBS	
2	GB-05225	5/8" X 2-1/4" GALV BOLT KIT	30	0.28 LBS	
3	GWF-05	5/8" GALV FLAT WASHER, 1.7OD	6	0.06 LBS	
4	GUB-53560	5/8" X 3-5/8" X 6" GALV U-BOLT	12	1.30 LBS	
5	SFG23175	ARM, STANDOFF - SFG23	6	63.28 LBS	
6	SFG2398	LABEL, SFG23RHDX	3	0.04 LBS	
7	SFG2204	WELDMENT, BACK VERTICAL ARM MOUNT	3	36.96 LBS	
8	XAU01	ANGLE, CROSSOVER, 1.9-3.5" X 1.9-3.5" OD	6	2.98 LBS	
9	MT546120	PIPE, 2.875"OD X 120"	12	57.45 LBS	
10	MT546084120	2.88" OD X 84" LONG PIPE	6	24.81 LBS	
11	MT546180276	PIPE, 2.875"OD X 180"	6	115.33 LBS	
12	GUB-4352	1/2" X 3" X 5-1/4" GALV U-BOLT	18	0.71 LBS	
13	GB-04145	1/2" X 1-1/2" GALV BOLT KIT	6	0.13 LBS	
14	GWF-04	1/2" GALV FLAT WASHER	6	0.04 LBS	
15	XP-2525	CROSSOVER PLATE KIT, 2-7/8 OD X 2-7/8 OD	12	8.37 LBS	
16	XP-2525-OFF	OFFSET CO PLATE KIT, 2-7/8ODX2-7/8OD	12	16.64 LBS	
17	XP-R	CROSSOVER PLATE, ROUND, UP TO 3.5" OD	6	6.20 LBS	

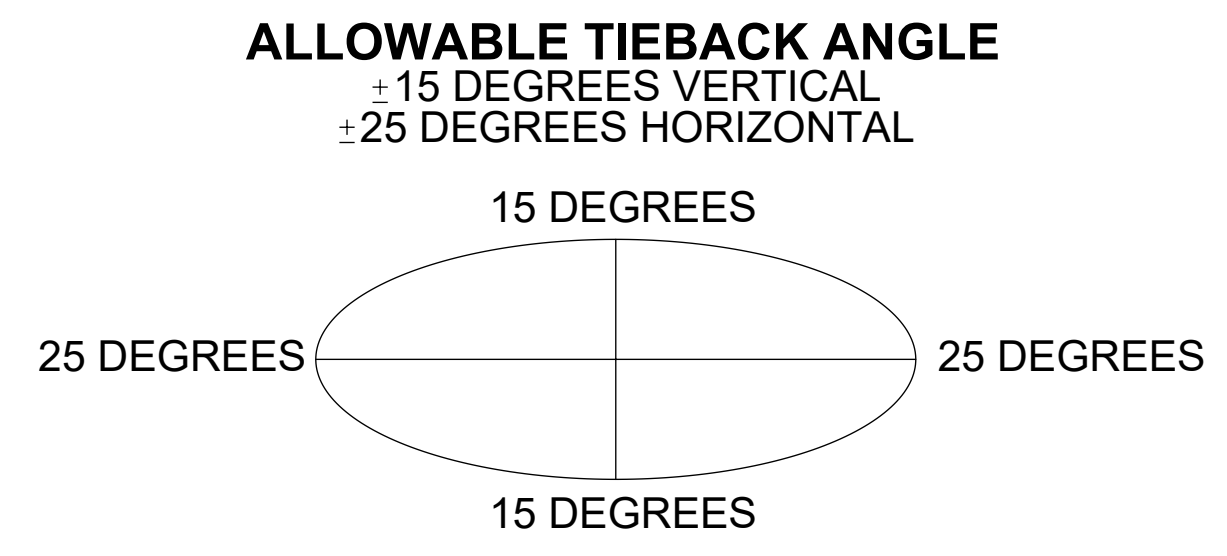

COMMSCOPE, INC. OF NORTH CAROLINA			
TITLE MONO 3 SCTR FR 15' FACE,(12) 120" ANT			
SIZE C	SCALE 1:20	DOCUMENT NO. MCG23RHDX-15M12120	
DRAWING			SHEET
VERSION 00	STATUS RE	REVISION A	3 OF 6

4

3

2

1

ALLOWABLE TIEBACK ANGLE

±15 DEGREES VERTICAL
±25 DEGREES HORIZONTAL

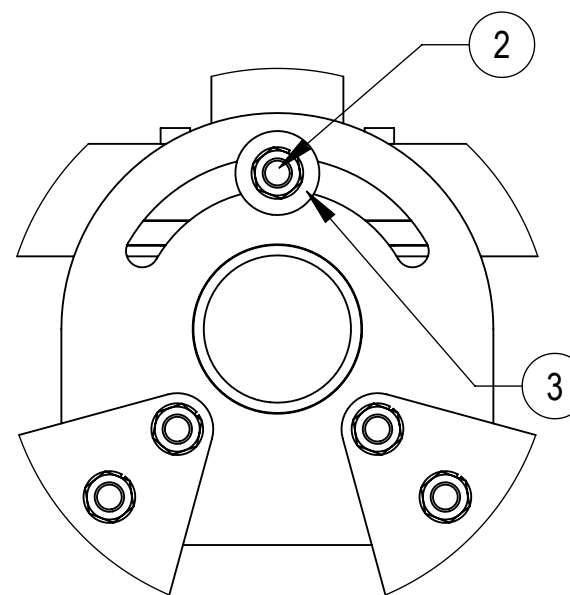
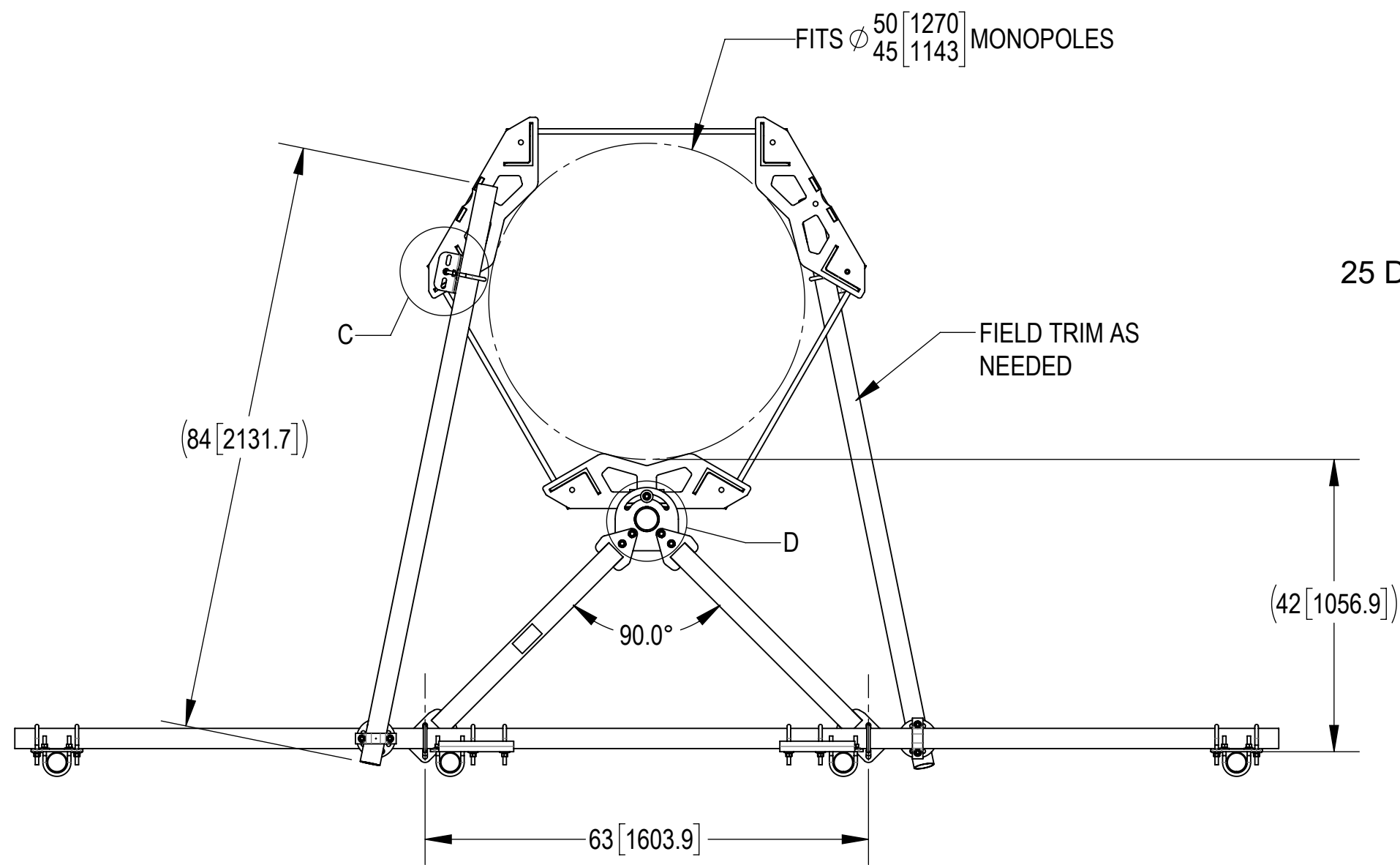
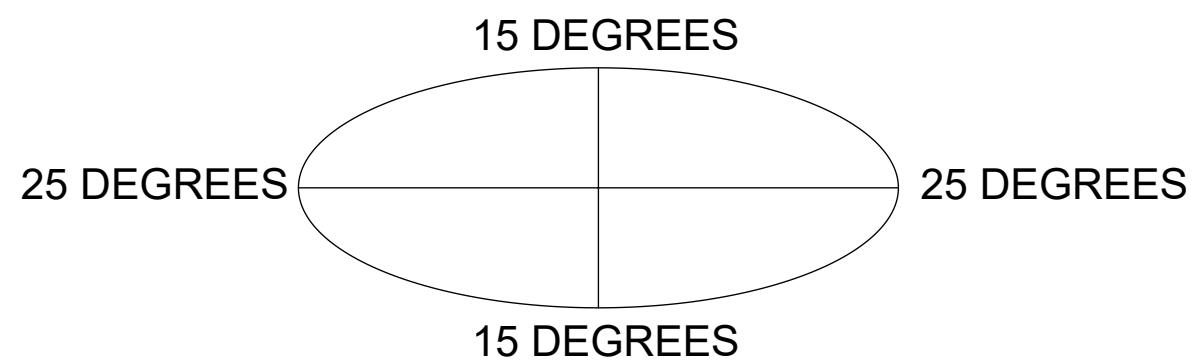

DETAIL D
SCALE 1:4

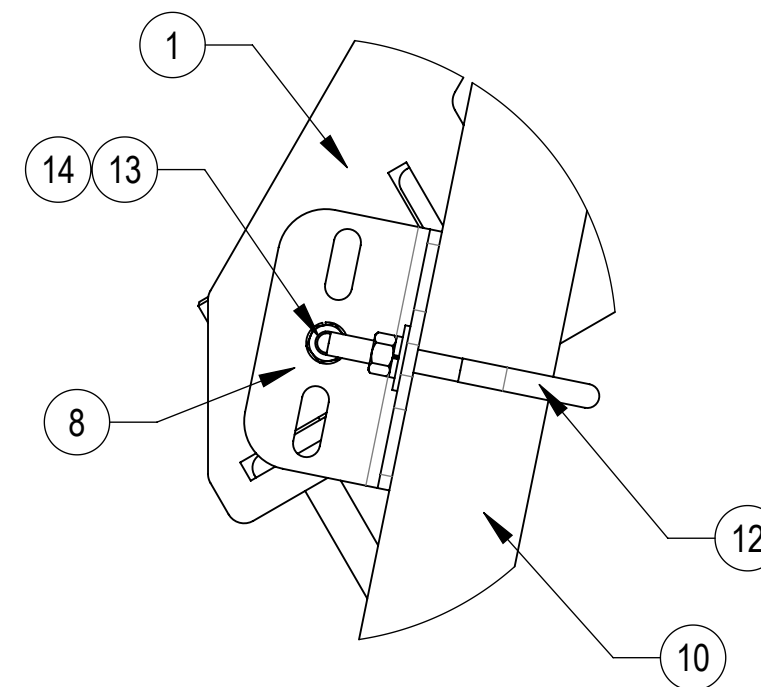

DETAIL C
SCALE 1:4

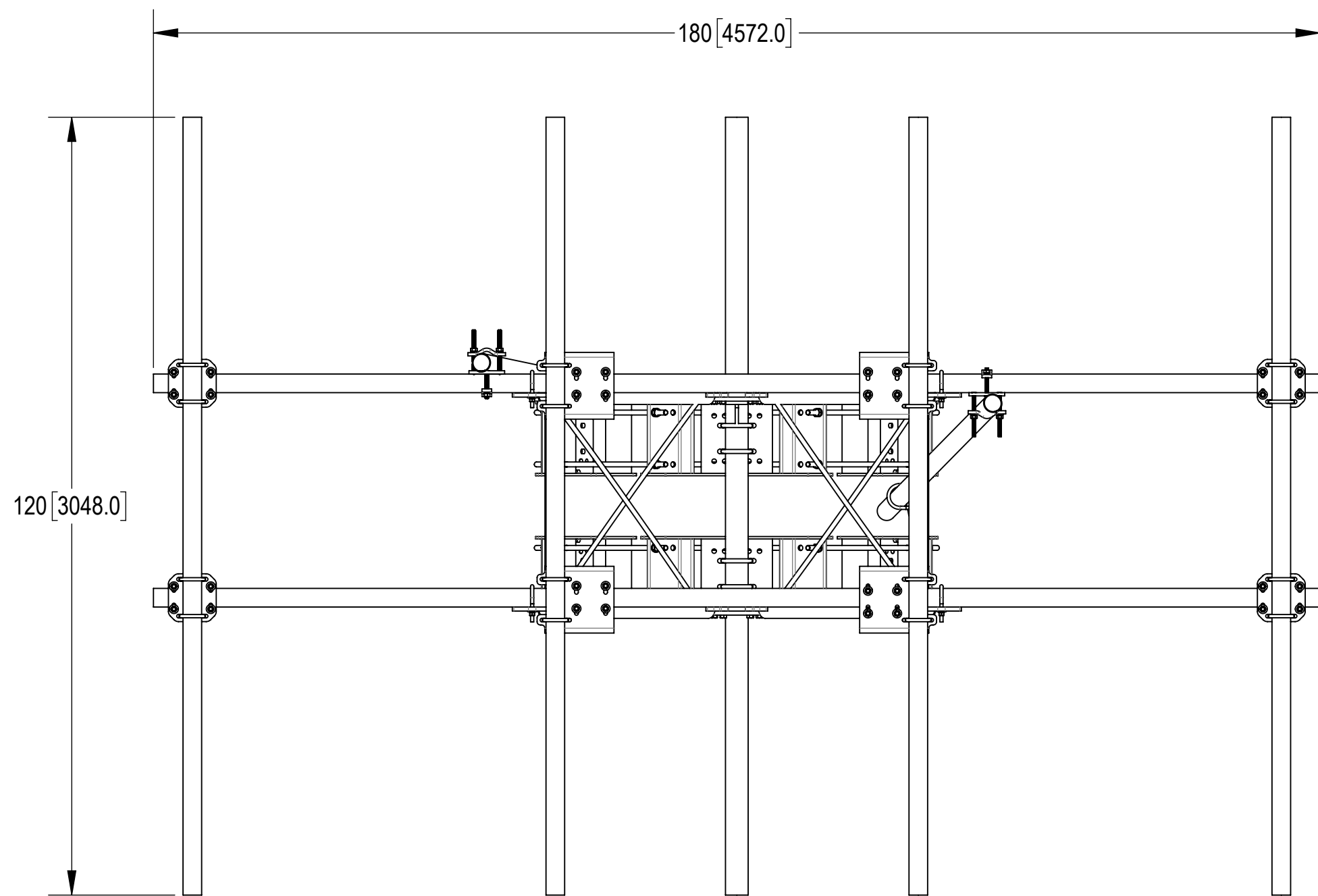

TOP
BOTTOM

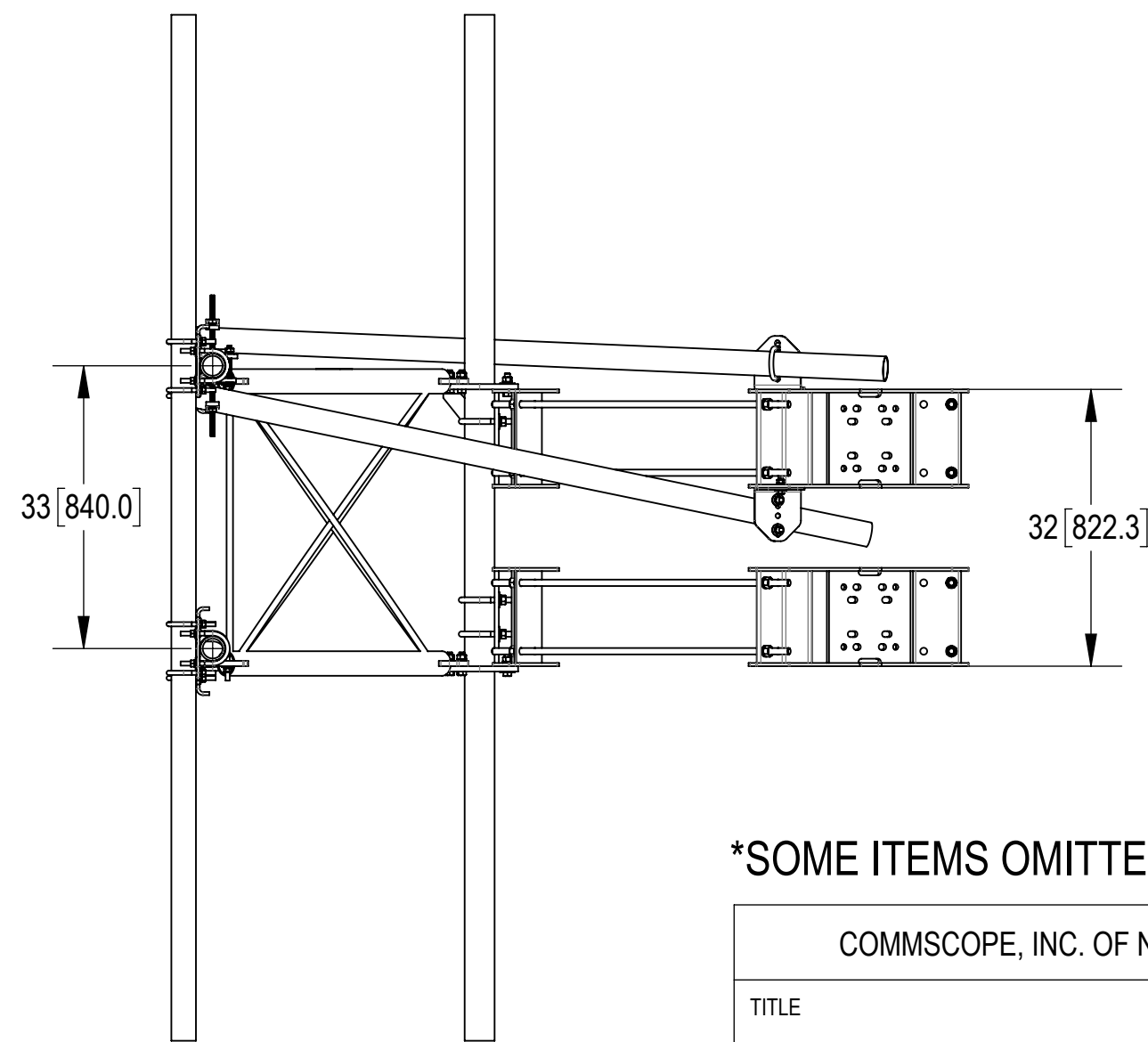

SOME ITEMS OMITTED FOR CLARITY

COMMSCOPE, INC. OF NORTH CAROLINA				
TITLE MONO 3 SCTR FR 15' FACE,(12) 120" ANT				
SIZE C	SCALE 1:20	DOCUMENT NO. MCG23RHDX-15M12120		
DRAWING		VERSION	STATUS	REVISION
		00	RE	A
SHEET 4 OF 6				

4

3



2

1

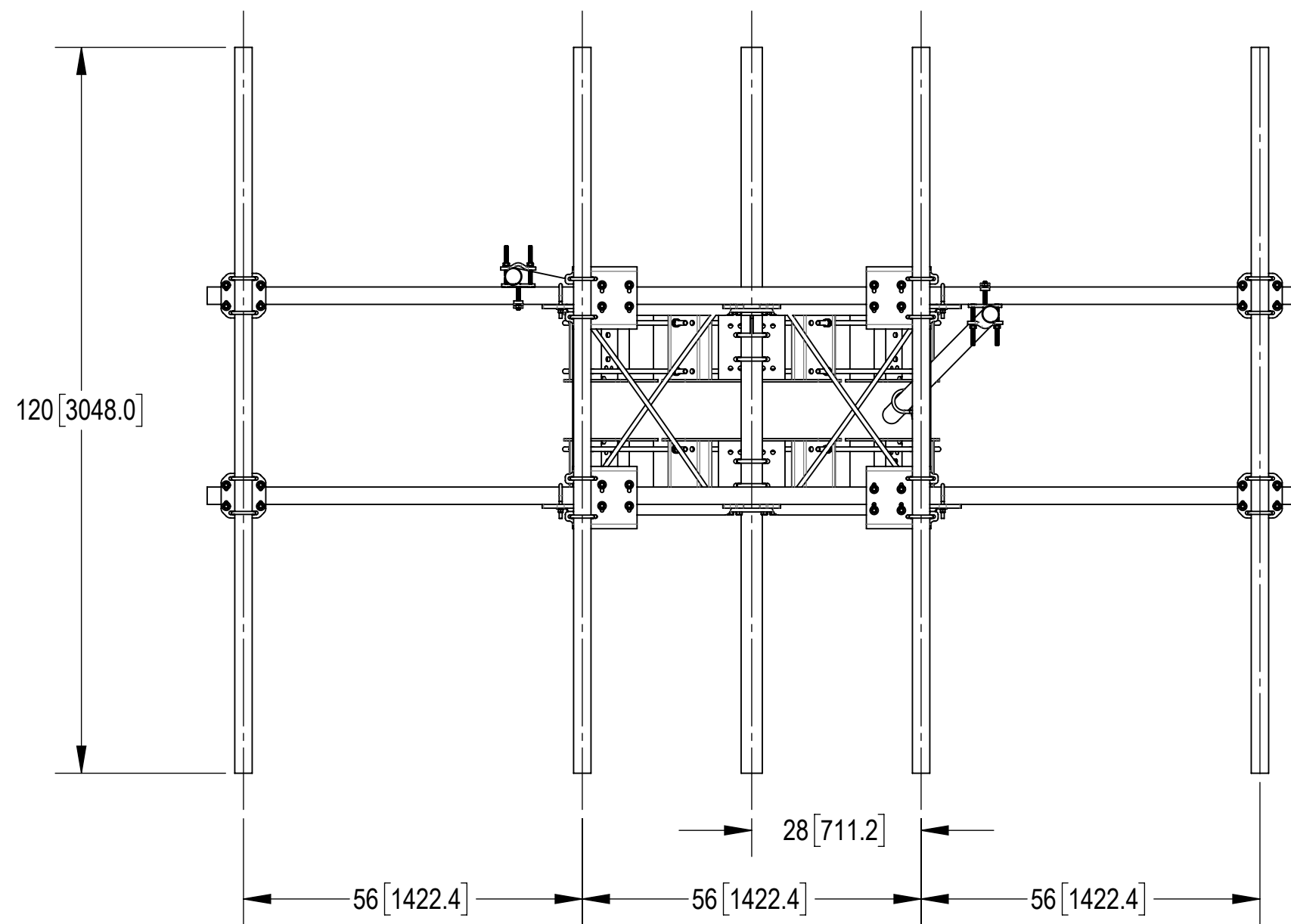
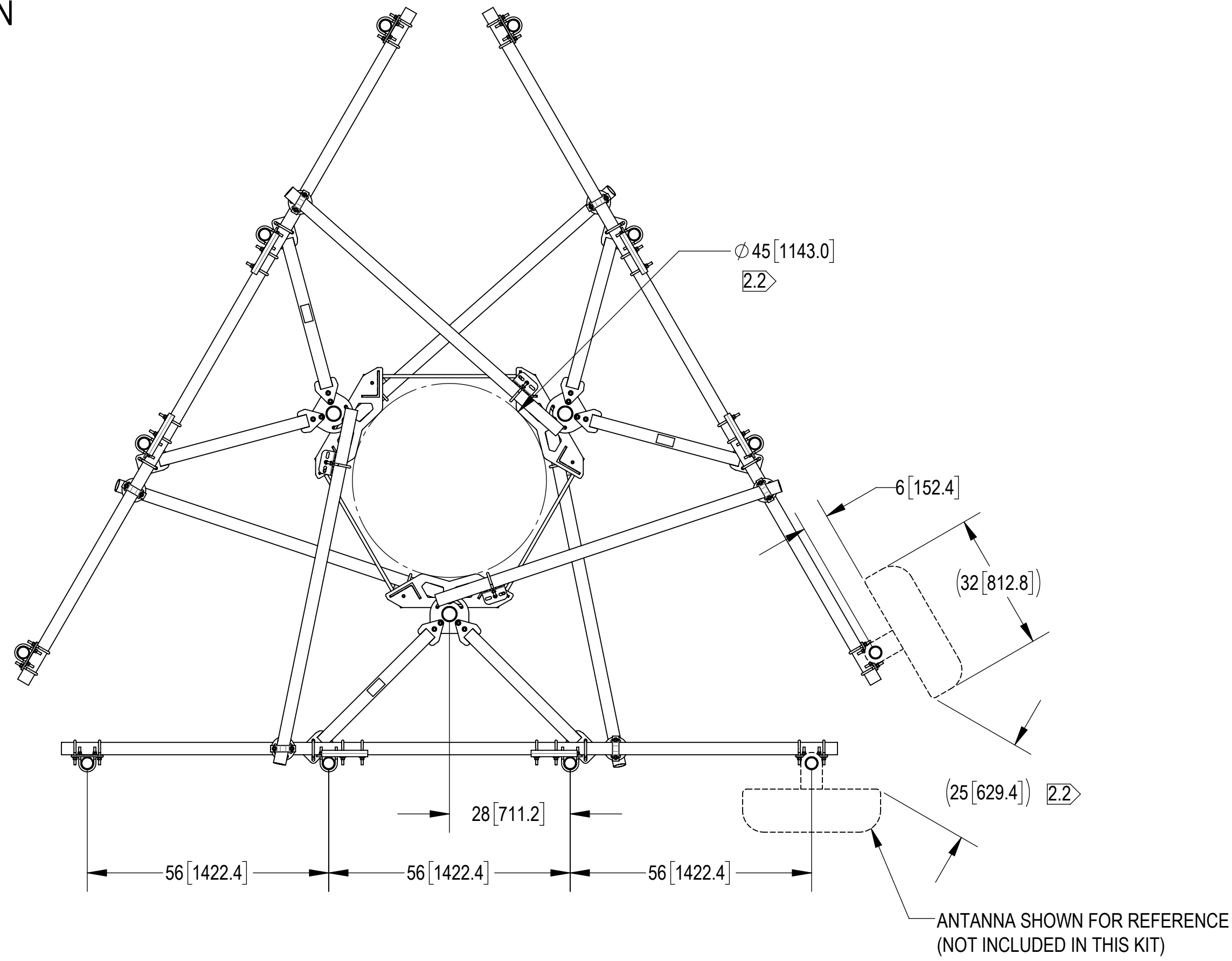
ANTENNA SPACING SHOWN



SOME ITEMS OMITTED FOR CLARITY

COMMSCOPE, INC. OF NORTH CAROLINA					
TITLE MONO 3 SCTR FR 15' FACE,(12) 120" ANT					
SIZE C	SCALE 1:24	DOCUMENT NO. MCG23RHDX-15M12120			
 		DRAWING			SHEET 5 OF 6
		VERSION 00	STATUS RE	REVISION A	

OPTIONAL ACCESSORIES:

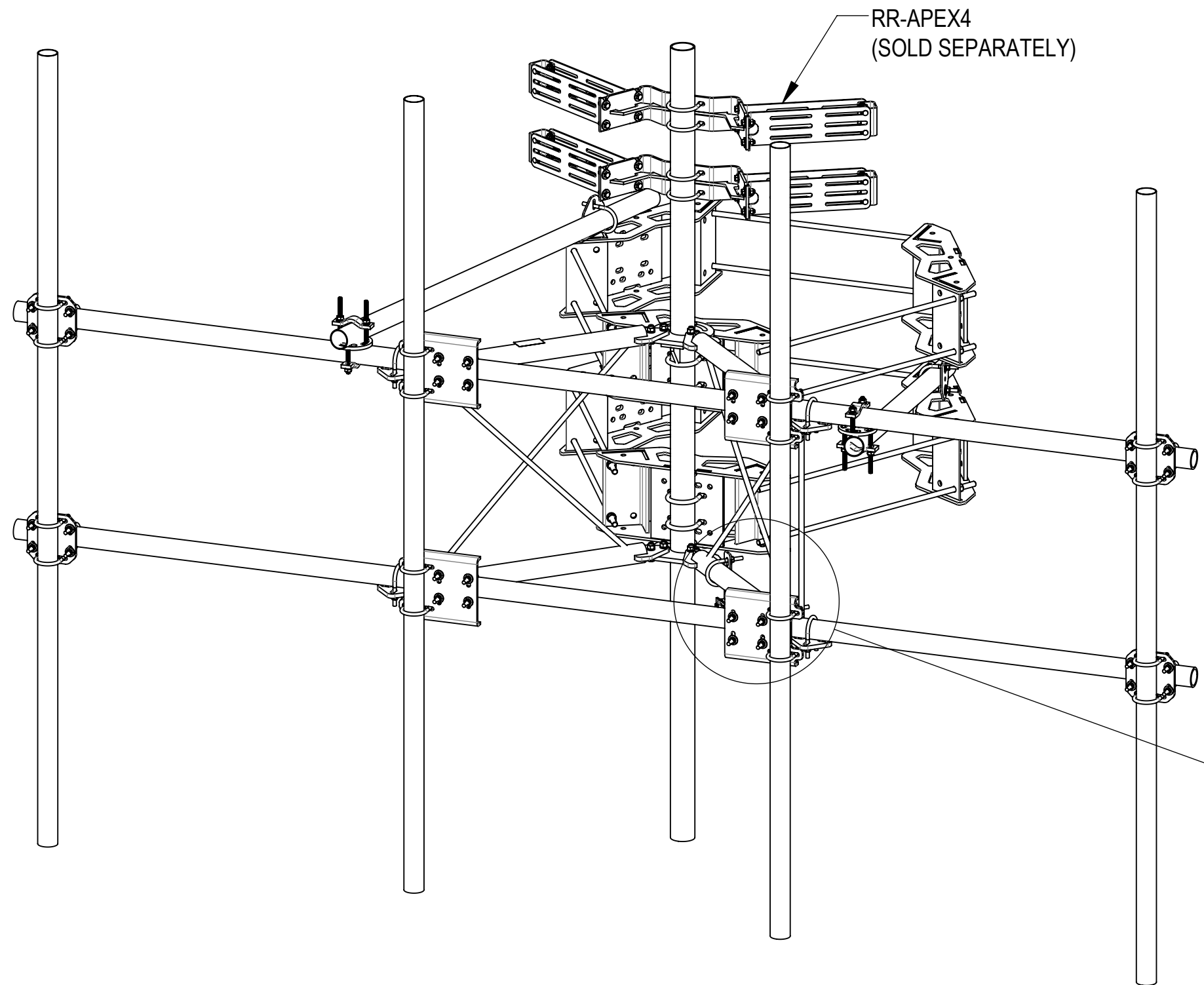

RR-APEX4
(SOLD SEPARATELY)

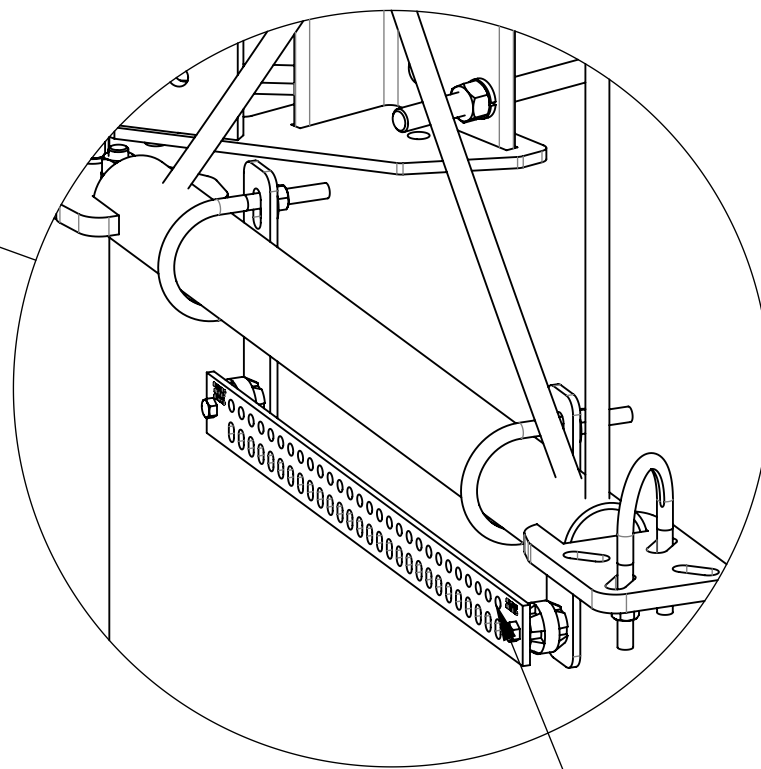

DETAIL E
SCALE 1 : 6

GBSF278
(SOLD SEPARATELY)

ALLOWABLE TIEBACK ANGLE
±15 DEGREES VERTICAL
±25 DEGREES HORIZONTAL

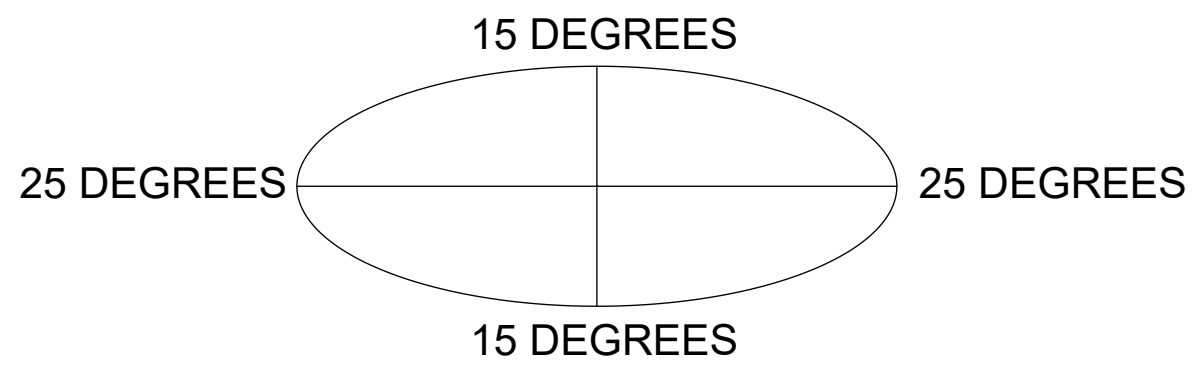

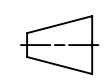
COMMSCOPE, INC. OF NORTH CAROLINA				
TITLE MONO 3 SCTR FR 15' FACE,(12) 120" ANT				
SIZE C	SCALE 1:24	DOCUMENT NO. MCG23RHDX-15M12120		
 		DRAWING		SHEET
		VERSION 00	STATUS RE	REVISION A