

4

3

2

1

- 1.0 GENERAL NOTES
  - 1.1 ALL METRIC DIMENSIONS ARE IN BRACKETS [X. X]
  - 1.2 FOR PATENT INFO: <https://www.cs-pat.com>
- 2.0 DESIGN NOTES
- 3.0 MANUFACTURING/SPECIAL REQUIREMENTS
  - 3.1 TIGHTEN ALL BOLTS SECURING FLAT PLATES BY THE TURN-OF-NUT METHOD. TIGHTEN ALL U-BOLTS USING TURN-OF-NUT METHOD WITH ATTENTION TO LEAVE EQUAL DISTANCE AND EQUAL FORCE ON EACH LEG OF THE U-BOLT.
- 4.0 TEST
- 5.0 PACKAGING
  - 5.1 PACKAGING SHALL MEET COMMScope REQUIREMENTS PER DOCUMENT IS-PL-3005
  - 5.2 PRINTED DOCUMENT TO BE PLACED INSIDE POLYBAG AND THEN IN SHIPPING CONTAINER
  - 5.3 EXTRA HARDWARE MAY BE SUPPLIED, BAGGED AND SHIPPED

REVISIONS			
REV.	DESCRIPTION	DATE	APPROVED
E	REDRAWN INDIVIDUAL DRAWING	RY1002 20JUN24	BA1025 40198581CMO

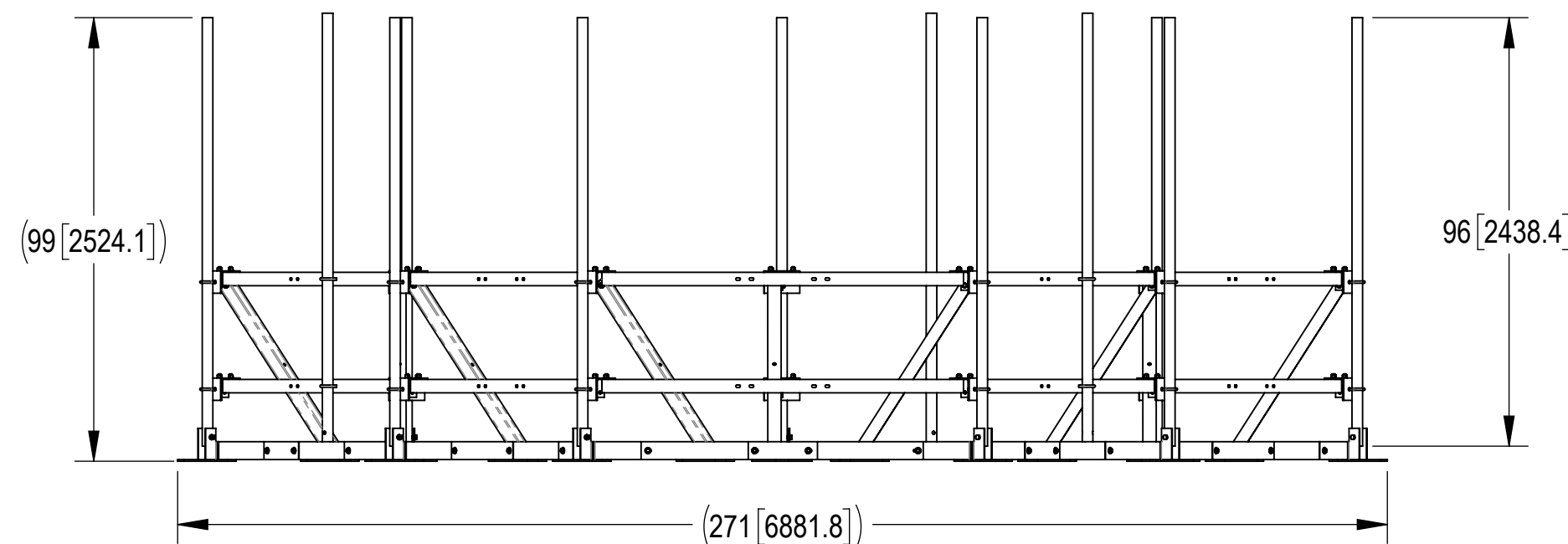
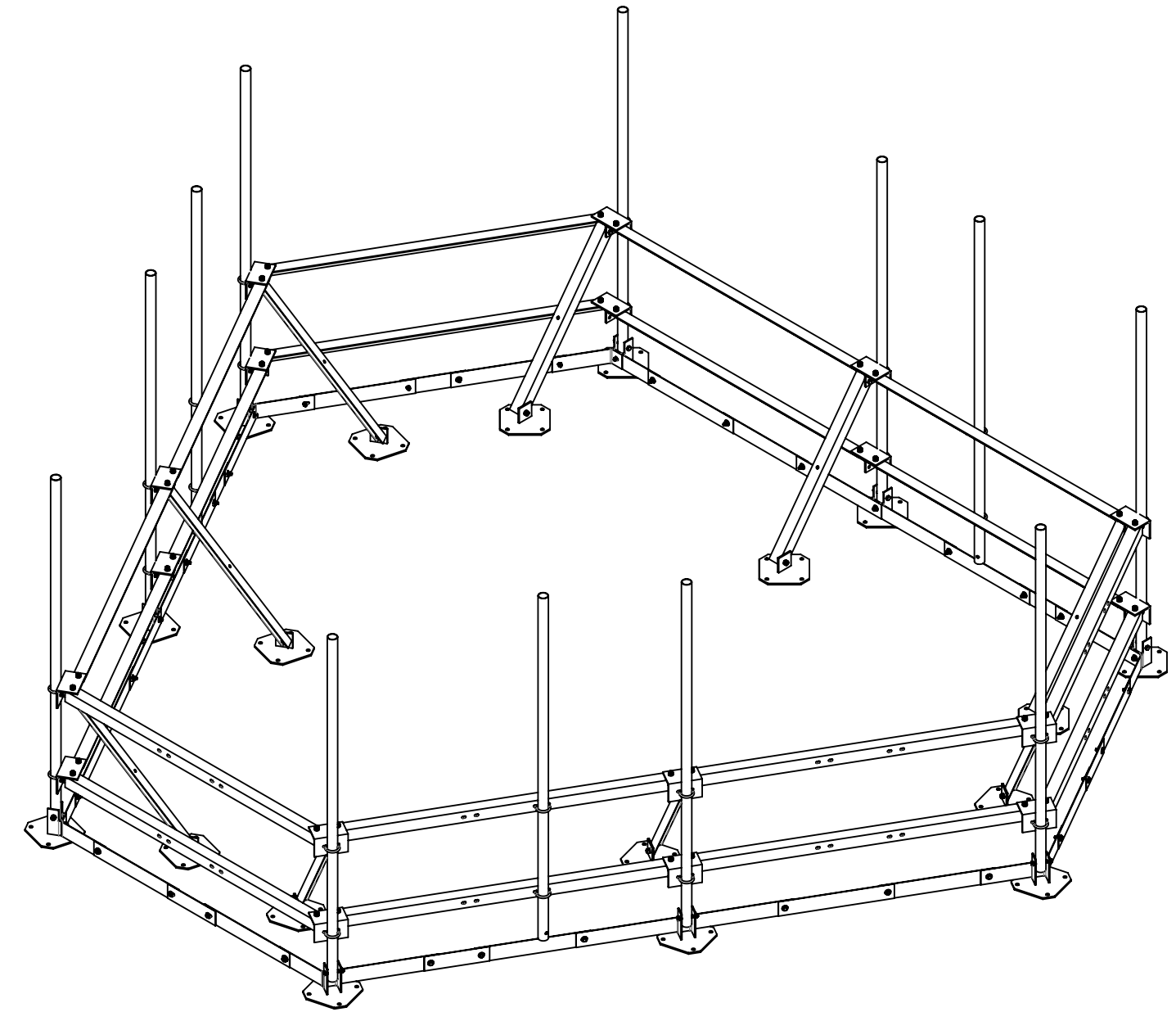
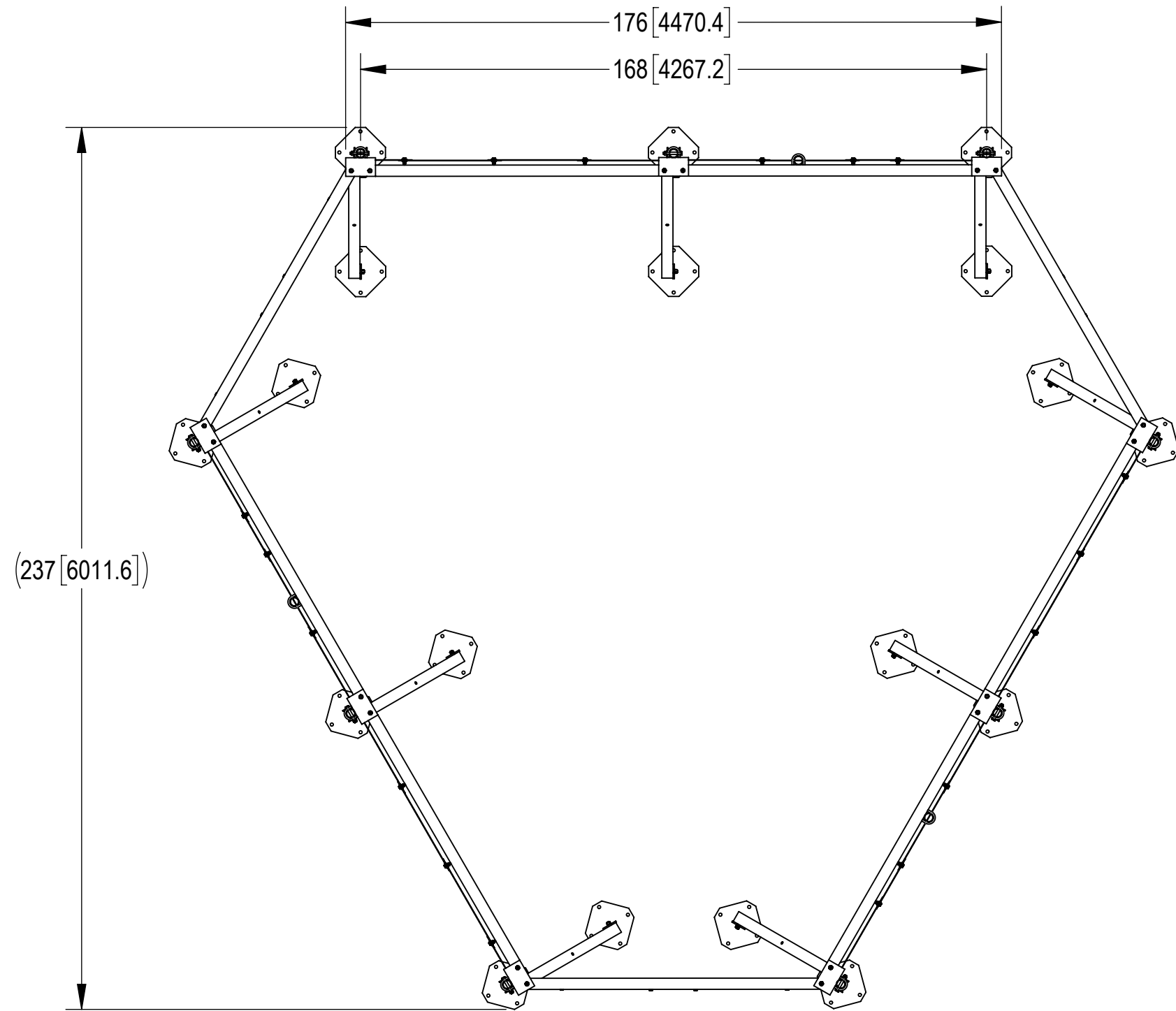

DENSITY	1643.81	lbs/in <sup>3</sup>
MASS	5824.19	lbs
VOLUME	58157.17	in <sup>3</sup>
SURFACE AREA		in <sup>2</sup>
HEIGHT	99"	
LENGTH	271"	
WIDTH	237"	

COMMScope, INC. OF NORTH CAROLINA										
TOLERANCES					SAP MATERIAL MASTER					
1 PLACE .X[X] ± 0.2[6.3]		3 PLACE .XXX[X] ± 0.060[1.5]			WT-RTA14-12-96					
2 PLACE .XX[X] ± 0.12[3.0]		ANGLES ± 2°								
FINISH					MATERIAL					
UNLESS OTHERWISE SPECIFIED DIMENSIONS ARE IN INCHES INTERPRET PER ANSI Y 14.5M-1994		NAME	DATE	TITLE						
		CE RY1002	20JUN24	ROOF TOP ASMBLY, 14' FACE, 12PIPE MT						
		RW RY1002	06/20/2024							
		AD YMENG	06/25/2024							
		RE RY1002	07/08/2024							
ECN 40198581CMO		SCALE		DOCUMENT NO.						
		1:36		WT-RTA14-12-96						
SIZE	Auth Group	INSL	MODEL			DRAWING				SHEET
C			VERSION	STATUS	REVISION	VERSION	STATUS	REVISION	1 OF 2	
			01	RE	E	00	RE	E		

4

3

2

1

4 3 2 1

D

C

B

A

D

C

B

A

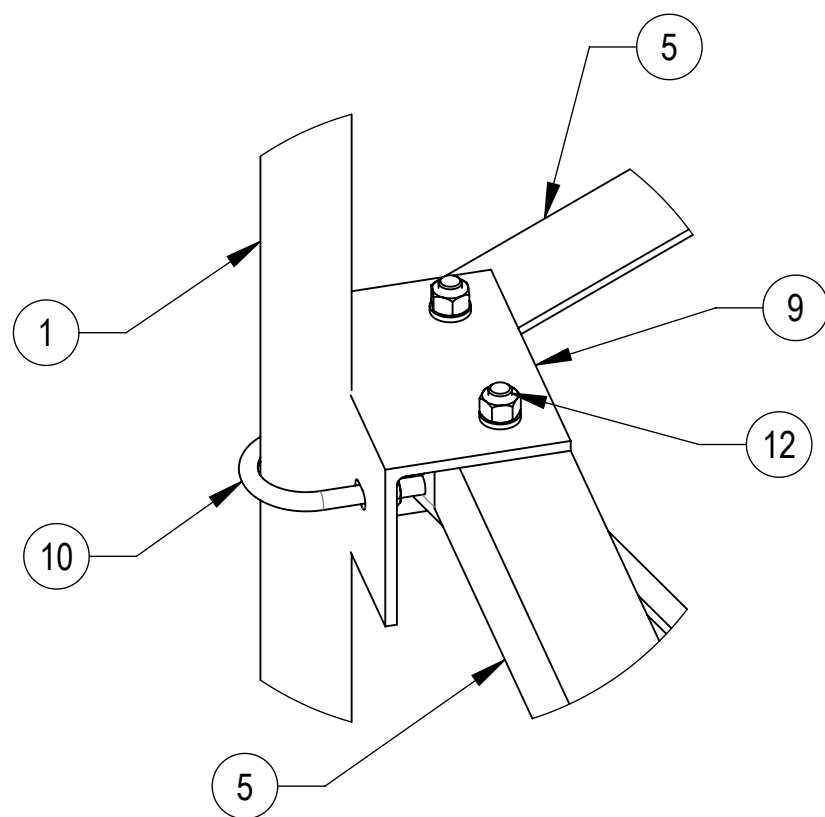

**DETAIL A**  
SCALE 1 : 5

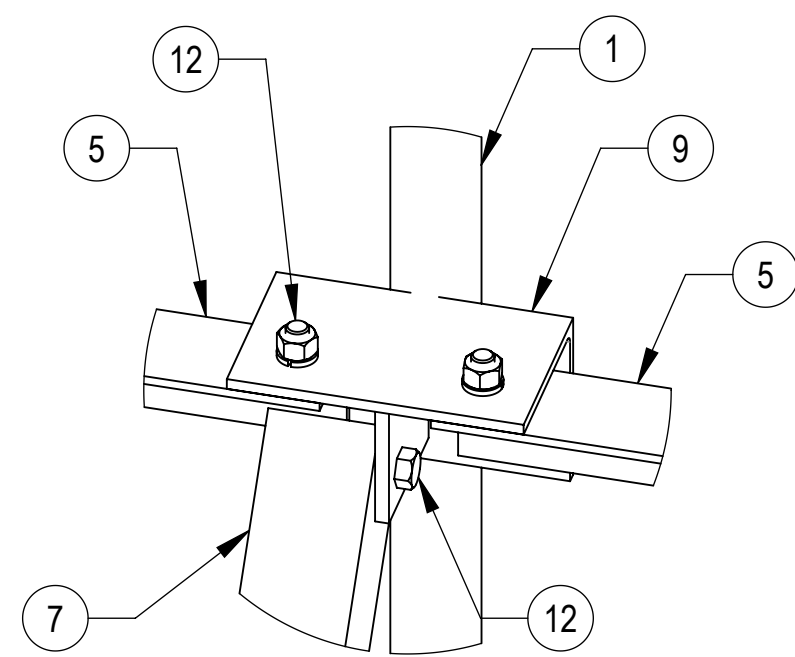

**DETAIL B**  
SCALE 1 : 5

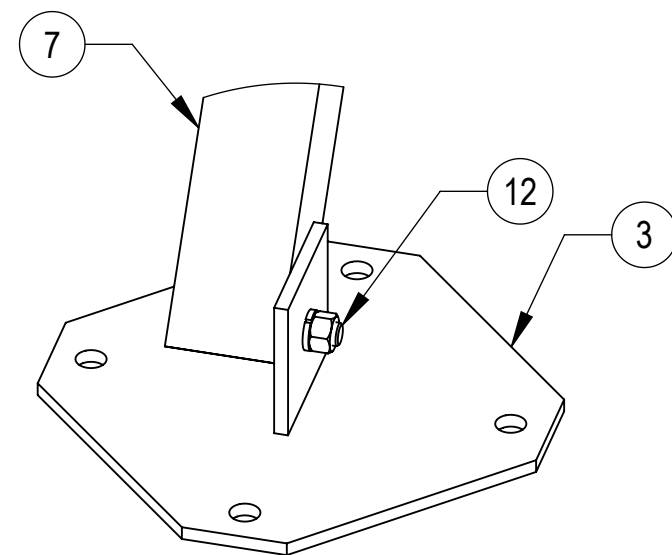

**DETAIL C**  
SCALE 1 : 5

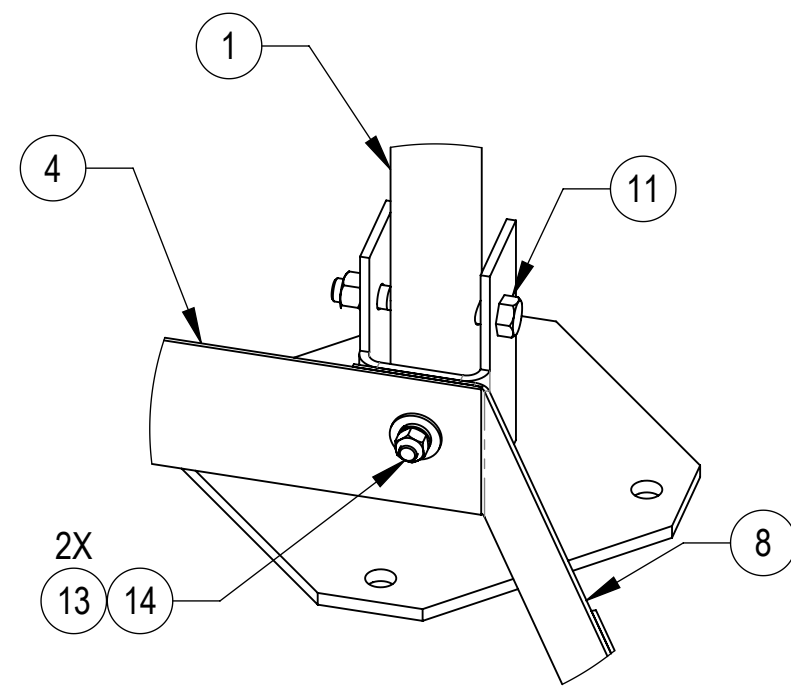

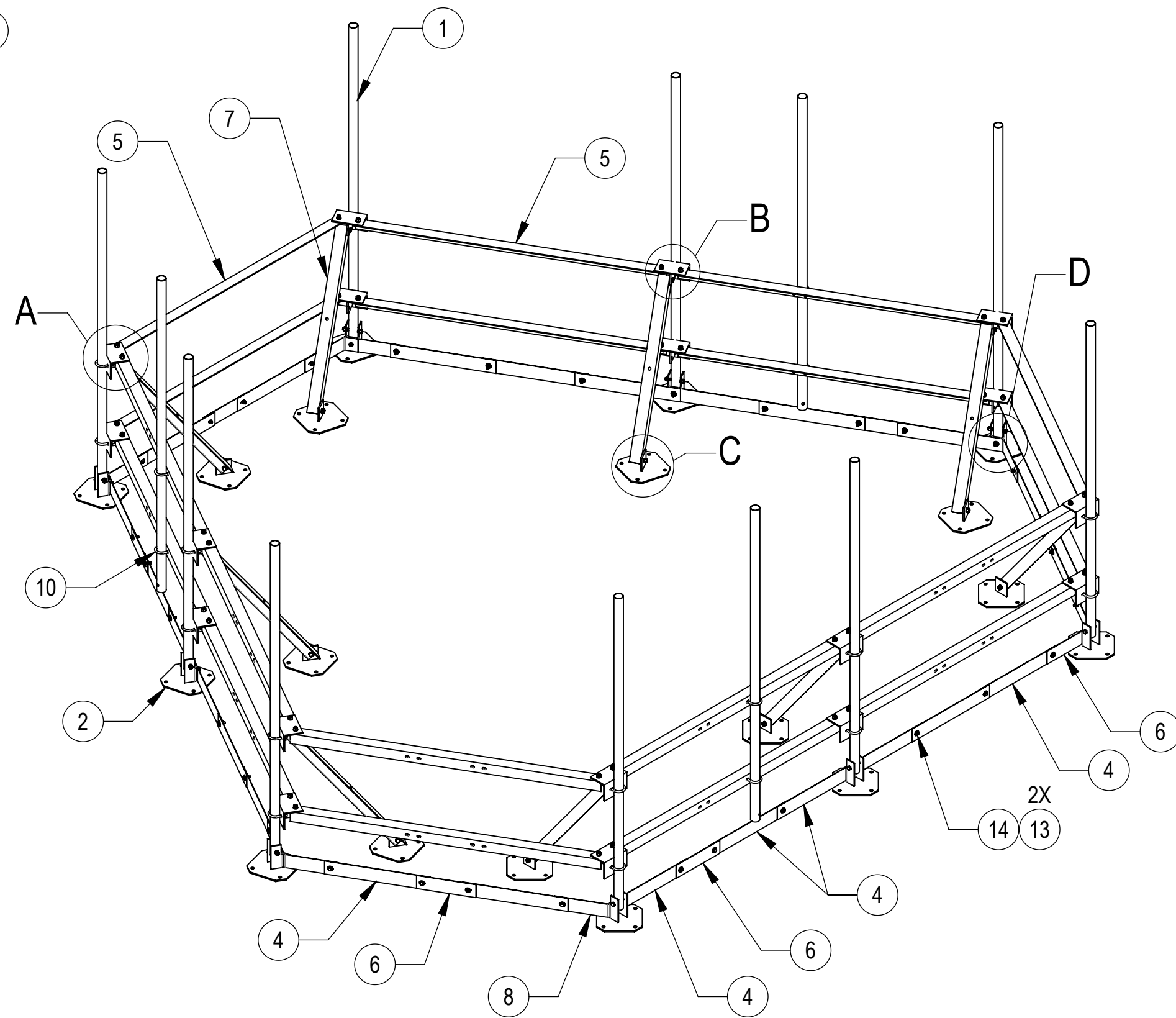

**DETAIL D**  
SCALE 1 : 5



COMPONENT PART NUMBERS PROVIDED FOR ASSEMBLY PURPOSES;  
INDIVIDUAL COMPONENTS MAY BE SHIPPED AS PARTS WITHIN AN INCLUDED KIT.

ITEM	PART NO.	DESCRIPTION	QTY.	WEIGHT	NOTE NO.
1	WTRTA32	PIPE FOR WTRTA SERIES	12	22.97 LBS	
2	WTRTA19	WELDED FOOT	9	16.49 LBS	
3	WTRTA20	REAR FOOT	9	14.56 LBS	
4	WTRTA27	LONG TOE BOARD SECTION	24	3.79 LBS	
5	WTRTA30	ANGLE, 7'	18	32.76 LBS	
6	WTRTA31	SHORT TOE BOARD SECTION	9	2.16 LBS	
7	WTRTA25	KICKER ANGLE	9	19.18 LBS	
8	WTRTA29	ANGLE TOE BOARD SECTION	6	2.43 LBS	
9	WTRTA21	WELDED BRACKET	18	8.34 LBS	
10	GUB-4240	1/2" X 2-1/2" X 4" GALV U-BOLT KIT	24	0.56 LBS	
11	GB-05445	5/8" X 4-1/2" GALV BOLT KIT	9	0.48 LBS	
12	GB-05145	5/8" X 1-1/2" GALV BOLT KIT	54	0.22 LBS	
13	GW-04	1/2" GALV FLAT WASHER	78	0.04 LBS	
14	GB-04145	1/2" X 1-1/2" GALV BOLT KIT	39	0.13 LBS	

COMMScope, INC. OF NORTH CAROLINA				
TITLE ROOF TOP ASMBLY, 14' FACE, 12PIPE MT				
SIZE <b>C</b>	SCALE <b>1:30</b>	DOCUMENT NO. WT-RTA14-12-96		
DRAWING		VERSION	STATUS	REVISION
 		00	RE	E
				SHEET 2 OF 2

© 2024 CommScope, Inc. Confidential

4

3

2

1

