

- 1. GENERAL NOTES
 - 1.1 ALL METRIC DIMENSIONS ARE IN BRACKETS
 - 1.2 FEATURES CRITICAL TO QUALITY ARE INDICATED IN ROUNDED BOX (XX)
- 2. DESIGN NOTES
- 3. MANUFACTURING/SPECIAL REQUIREMENT
 - 3.1 "ANTI-SEIZE" SHALL BE USED ON ALL STAINLESS TO STAINLESS HARDWARE CONNECTIONS
 - 3.2 "NO-OX" SHALL BE USED ON ALL CHASSIS TO GROUND CABLE CONNECTIONS
 - 3.3 INSTALL POLE MOUNT BRACKET ON BACK OF ENCLOSURE USING HARDWARE PROVIDED WITH THE ENCLOSURE
- 4. TEST
- 5. PACKAGING
 - 5.1 PACKAGING SHALL MEET COMMSCOPE REQUIREMENTS PER DOCUMENT IS-PL-3005
 - 5.2 PLACE ITEMS 2,3,4,5,6,7,9 AND 10 IN POLYBAG FOR CUSTOMER INSTALLATION
 - 5.3 PRINTED DOCUMENT TO BE PLACED IN ENCLOSURE FOR CUSTOMER REFERENC
 - 5.4 REFERENCE DOCUMENT PACK-860661823S-XX FOR PACKAGIN REQ.

REVISIONS			
REV.	DESCRIPTION	DATE	APPROVED
A	INSTAL RELEASE	CA1022 15JAN22	CIA 40138941CMO
B	CHANGE MID IN SAP MATERIAL MASTER	CA1022 14FEB22	CIA 40138941CMO
C	ADDED SHEET 2 TO 4 FOR INSTALLATION	LL1090 02FEB22	SH1132 40164198CMO

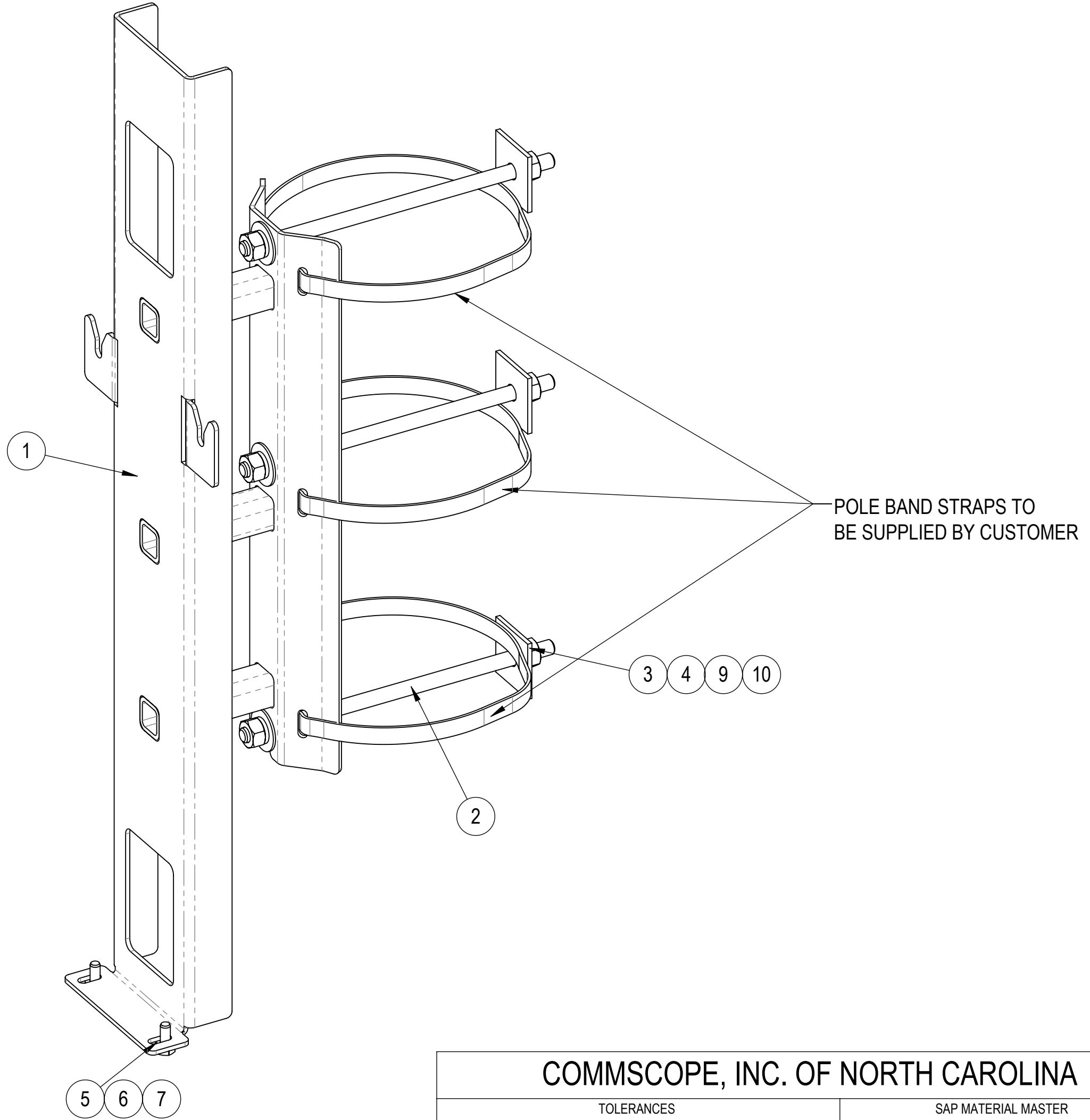

COMPONENT PART NUMBERS PROVIDED FOR ASSEMBLY PURPOSES;
INDIVIDUAL COMPONENTS MAY BE SHIPPED AS PARTS WITHIN AN INCLUDED KIT.

ITEM NO.	PART NUMBER	DESCRIPTION	QTY.	NOTE
1	MTM1149-0100-XX	WELD,ENCLOSURE POLE MOUNT,MV2	1	
2	MT-382-14	5/8" X 14" THREADED ROD	3	5.2
3	SW-58	BACKING PLATE, .188" X 2.5" X 2.5" W/ 11/16" HOLE	3	5.2
4	GWF-05	5/8" GALV FLAT WASHER	6	5.2
5	MTC978706	M10 STAINLESS STEEL FLAT WASHER	2	5.2
6	MTC9416	M10 X 25mm HEX BOLT SS	2	5.2
7	100522-37	WSHR,LK,SPLT, M10,SST, PASS	2	5.2
9	GWL-05	5/8" GALV LOCK WASHER	6	5.2
10	GN-05	5/8" GALV HEX NUT	6	5.2
9000	860661823S-XX	MV2-5" STNDOFF,WOOD-POLE	1	5.3

DENSITY	20.4775	lbs/in ³
MASS	20.4775	lbs
VOLUME	13569159.8262	in ³
SURFACE AREA	4631597.9998	in ²
HEIGHT	43.8	[1111.56]
LENGTH	20.1	[511.30]
WIDTH	10.2	[258.01]

COMMSCOPE, INC. OF NORTH CAROLINA

TOLERANCES		SAP MATERIAL MASTER	
1 PLACE .X[X] ± 0.25[6]	3 PLACE .XXX[XX] ± 0.060[1.50]	860661823S-XX	
2 PLACE .XX[X] ± 0.12[3.0]	ANGLES ± 2°		
FINISH		MATERIAL	
UNLESS OTHERWISE SPECIFIED DIMENSIONS ARE IN INCHES INTERPRET PER ANSI Y 14.5M-1994		TITLE	
CE	LL1090	DATE	02/23/2023
RW	LL1090	DATE	02/23/2023
AD		MV2-XX"-STNDOFF,WOOD-POLE	
RE			
ECN	40164198CMO	SCALE	1:4
SIZE		DOCUMENT NO.	
Auth Group INSL		860661823S-XX	
MODEL		DRAWING	
VERSION	STATUS	REVISION	VERSION
05	RE	C	05
SHEET		REVISION	
1 OF 4		C	

4

3

2

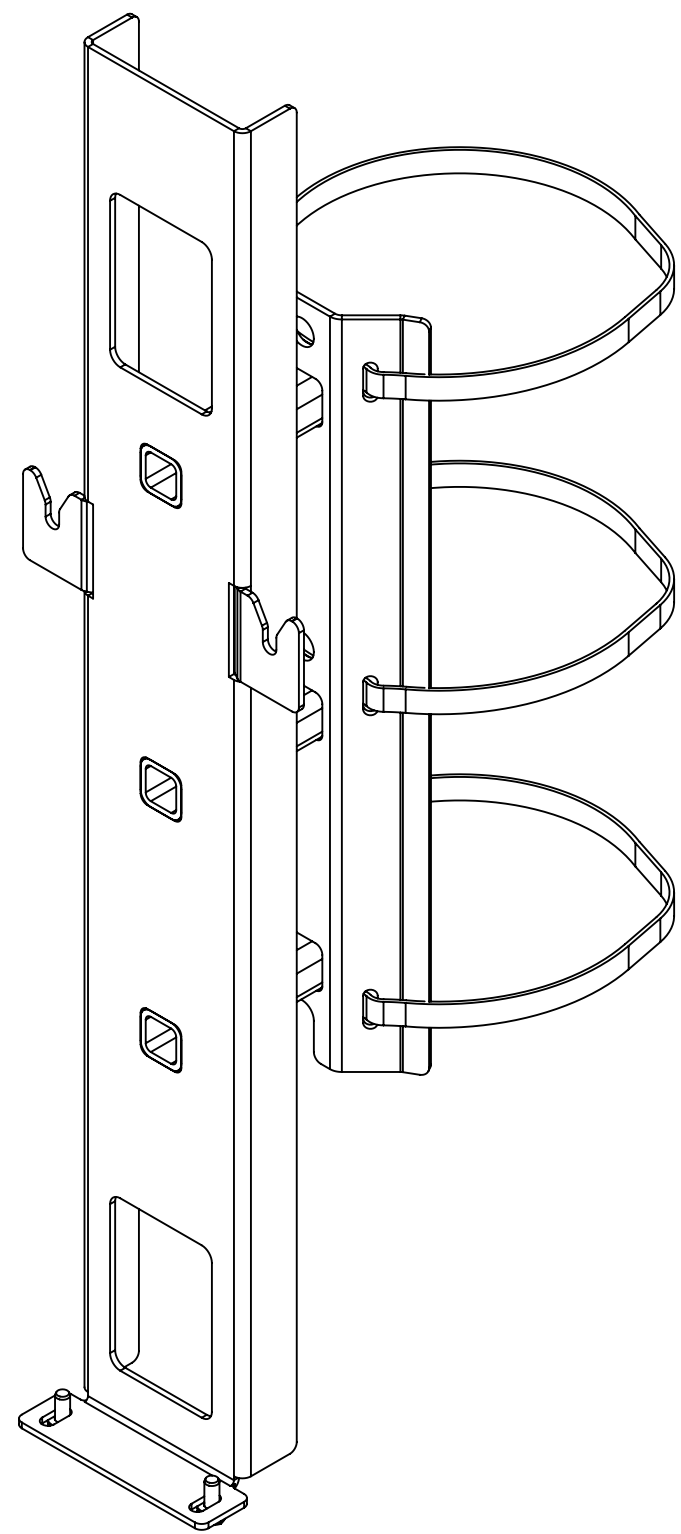
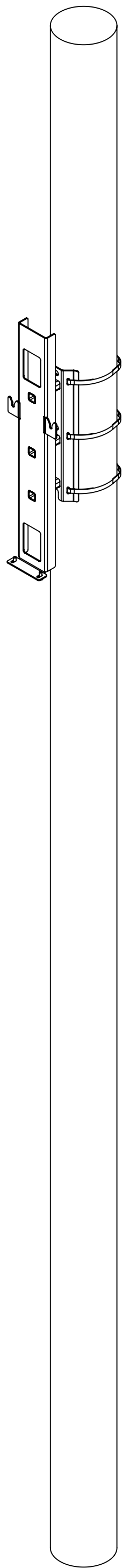

1

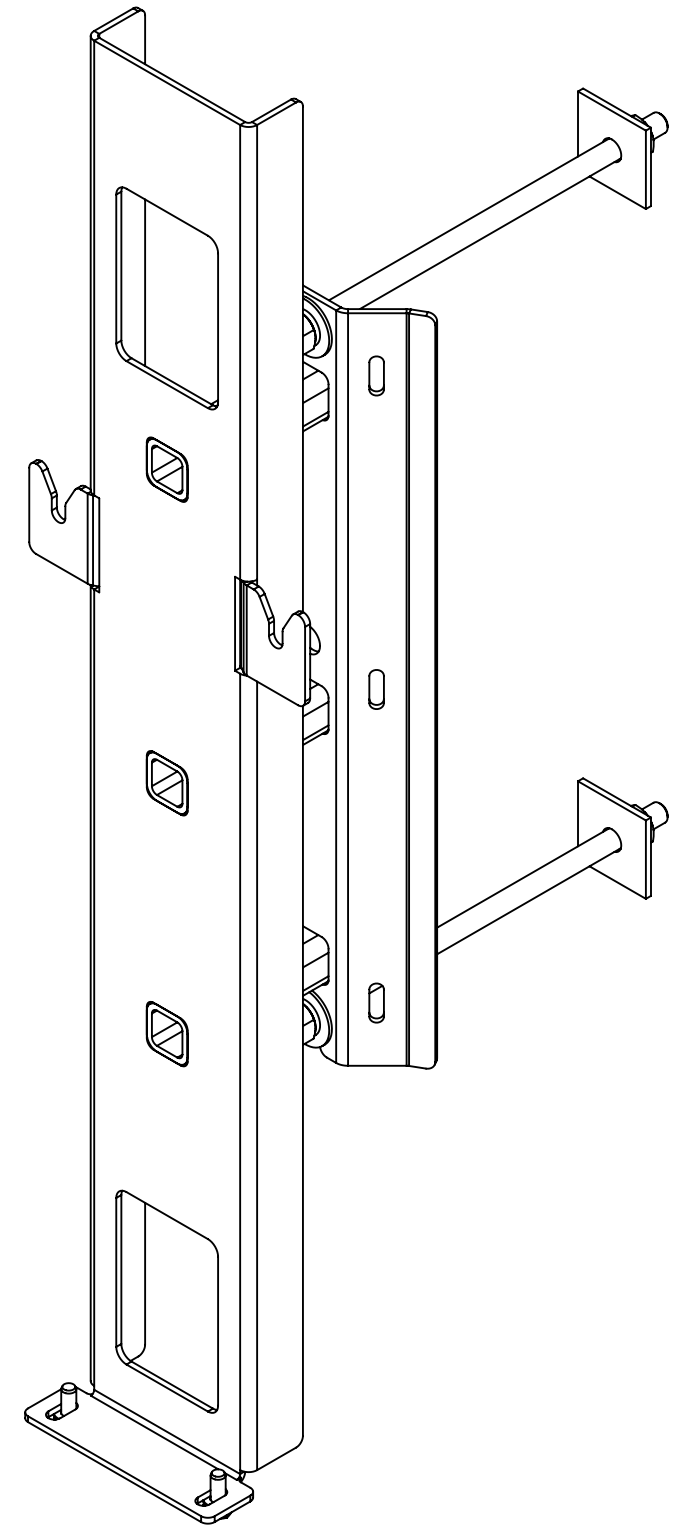
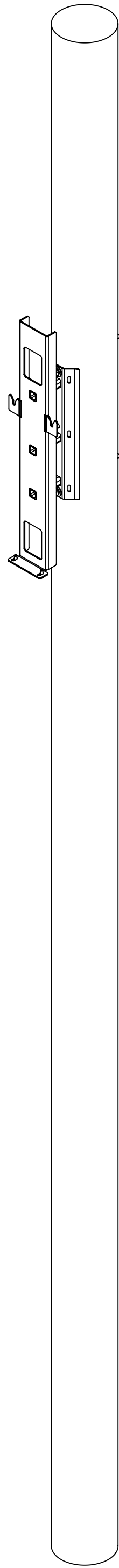

BAND MOUNT



THROUGH BOLT MOUNT

COMMSCOPE, INC. OF NORTH CAROLINA				
TITLE MV2-5"-STNDOFF, WOOD-POLE				
SIZE C	SCALE 1:8	DOCUMENT NO. 860661823S-XX		
 		DRAWING		SHEET 2 OF 4
		VERSION 05	STATUS RE	

4

3

2

1

D

D

C

C

B

B

A

A

4

3

2

1

NOTE
3.1 ALL HARDWARE MUST BE PROPERLY TORQUE.

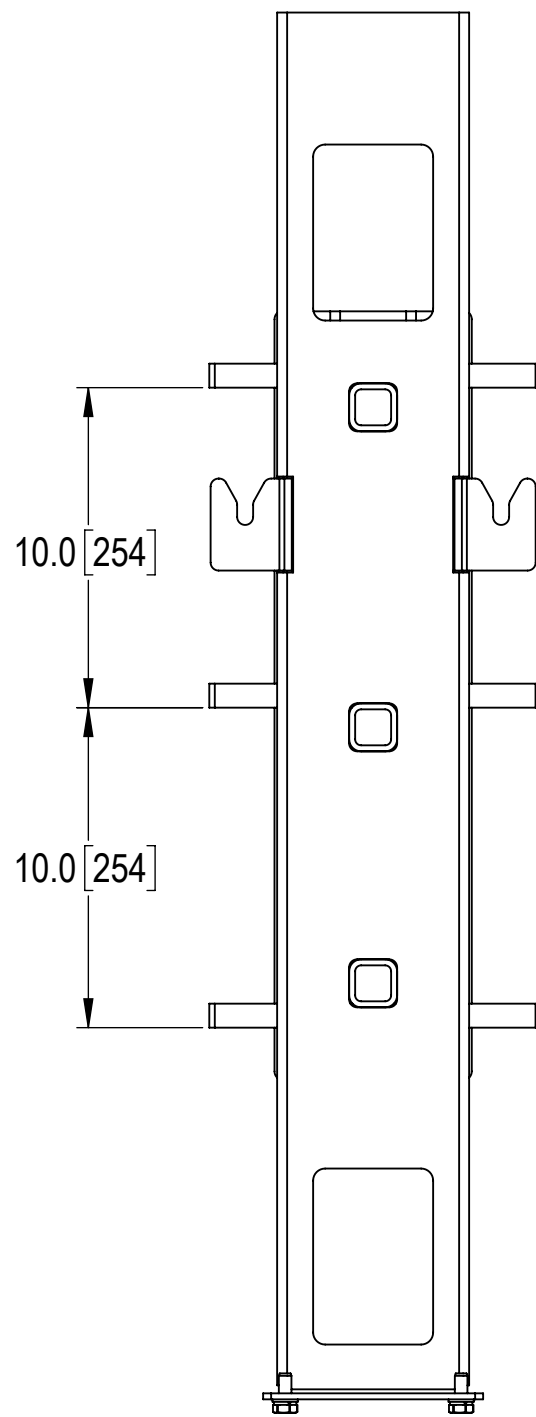
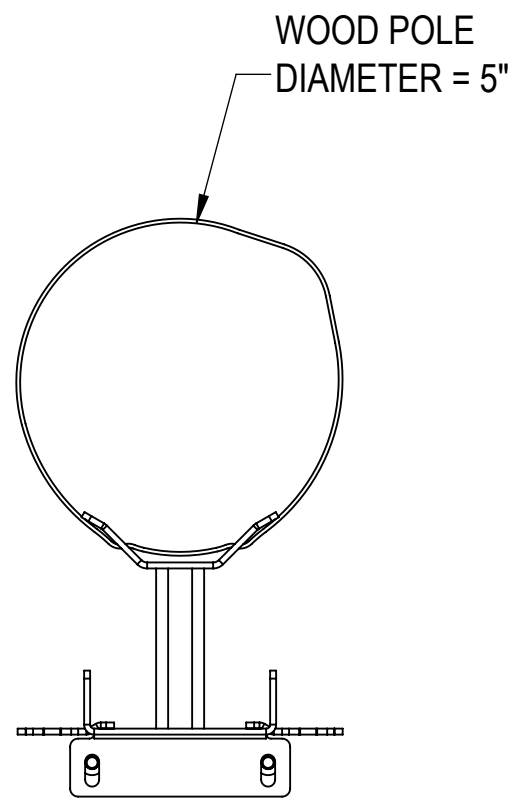
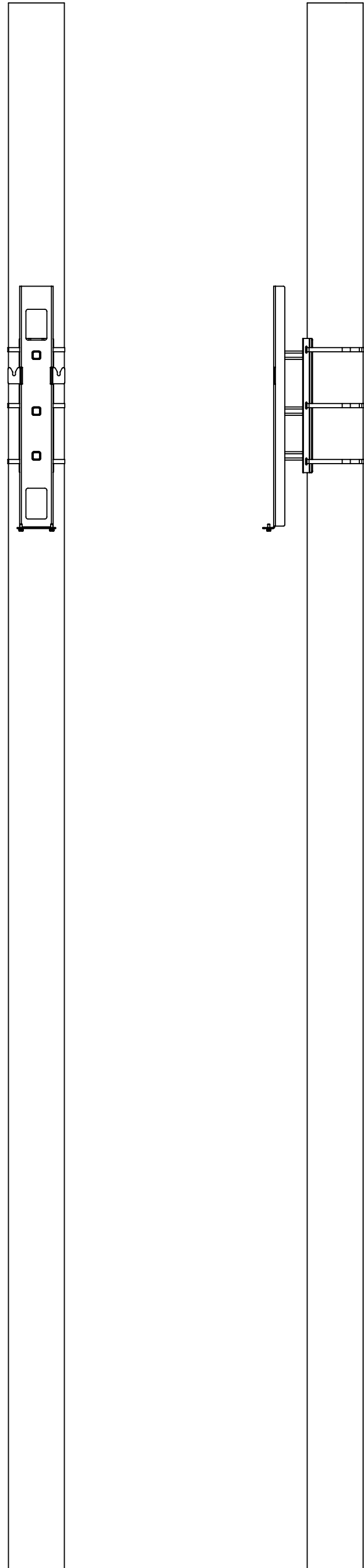

BAND MOUNT

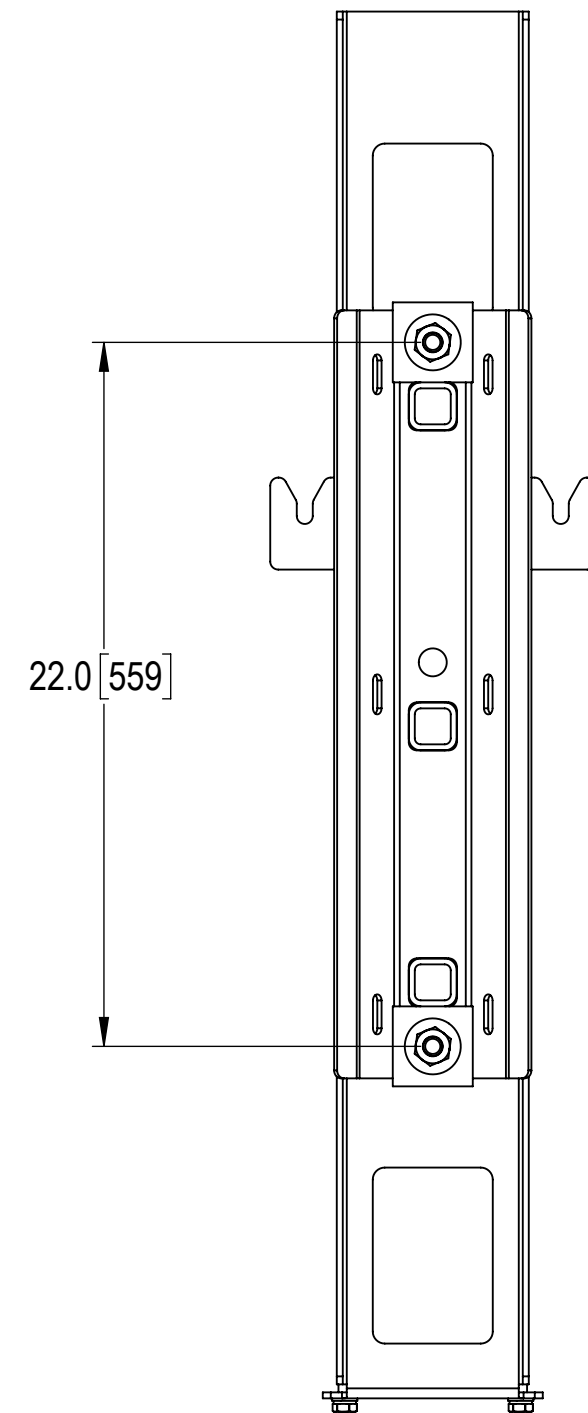
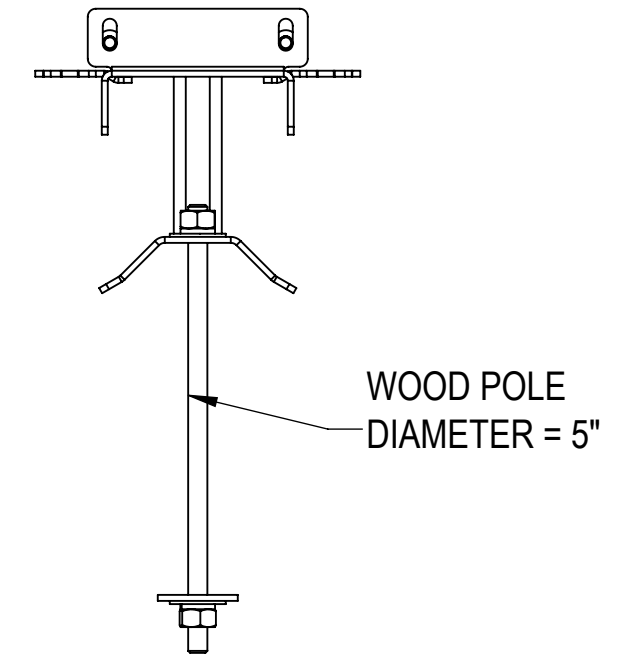
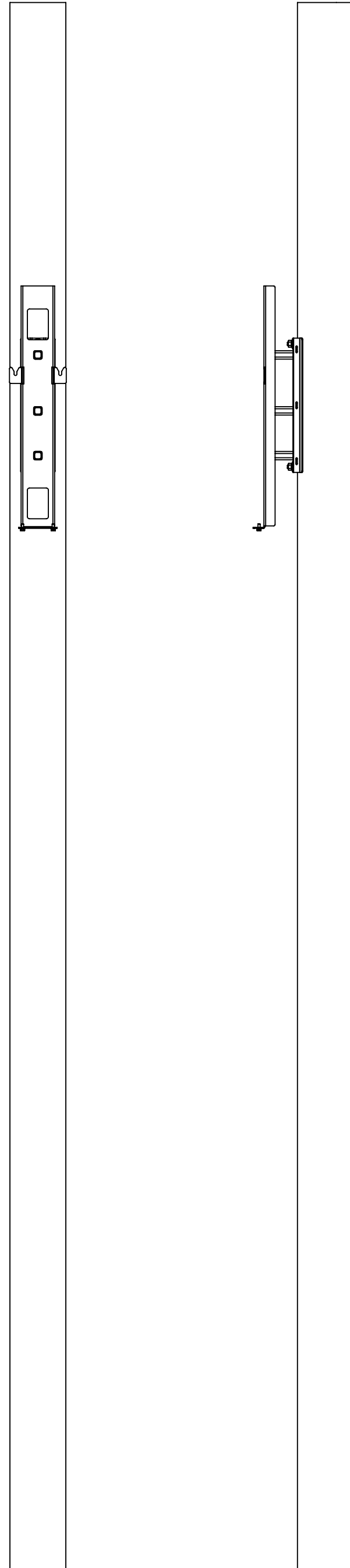

THROUGH BOLT MOUNT

COMMSCOPE, INC. OF NORTH CAROLINA				
TITLE MV2-5"-STNDOFF, WOOD-POLE				
SIZE C	SCALE 1:48	DOCUMENT NO. 860661823S-XX		
DRAWING		VERSION		SHEET
REVISION		05	RE	C
				3 OF 4

4

3

2

1

4

3

2

1

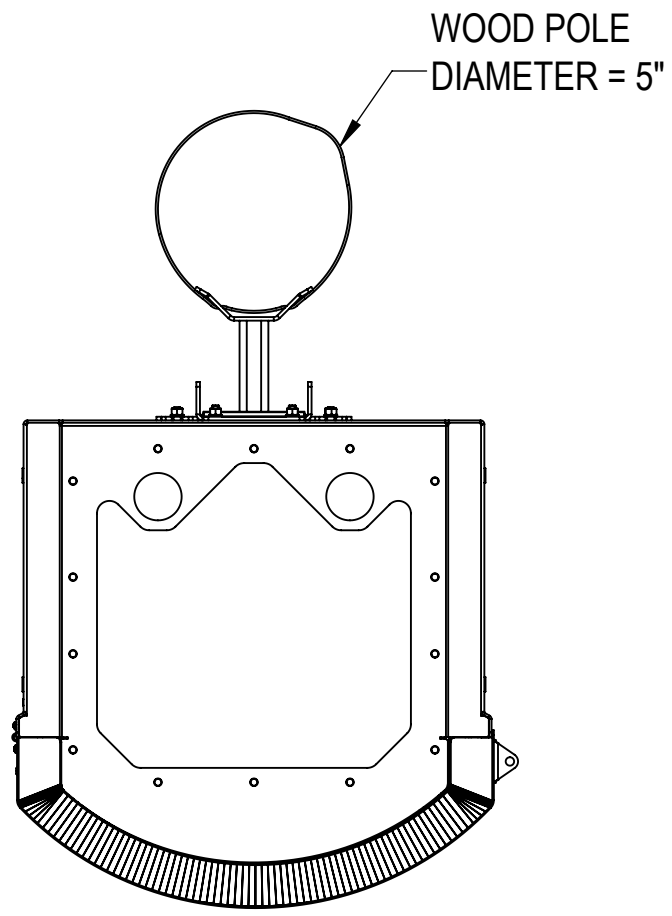

TOP VIEW

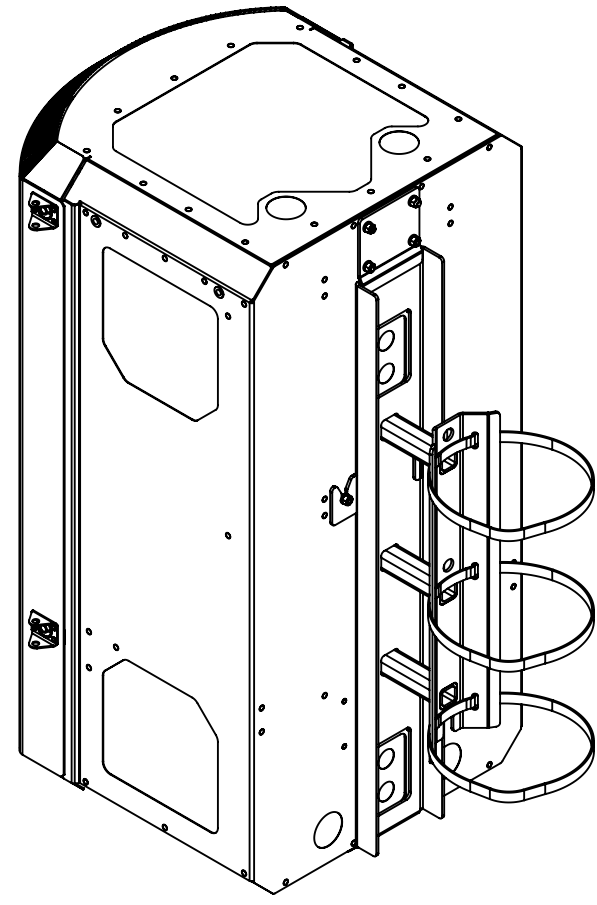

REAR ISOMETRIC VIEW

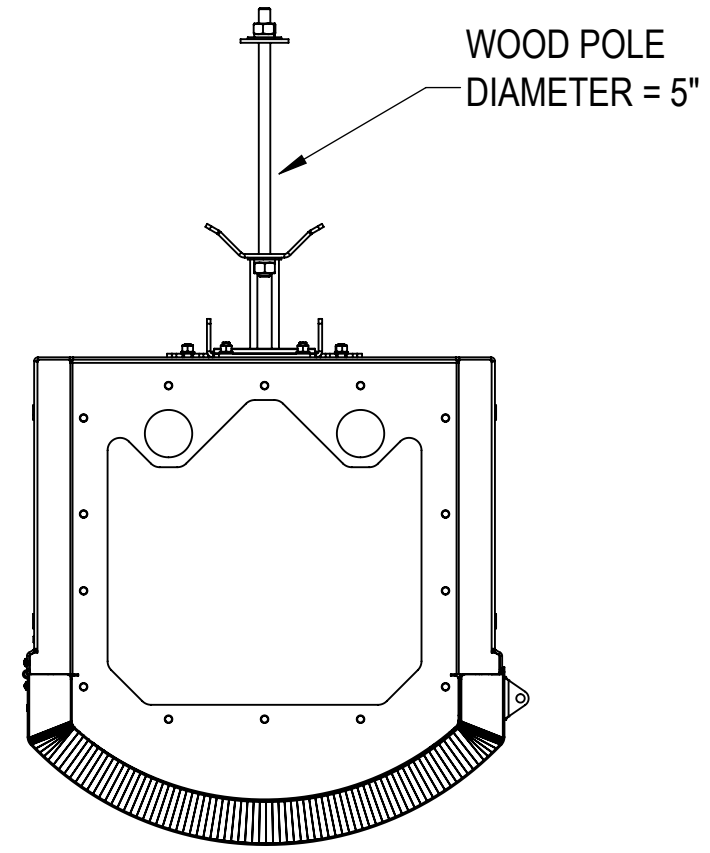

TOP VIEW

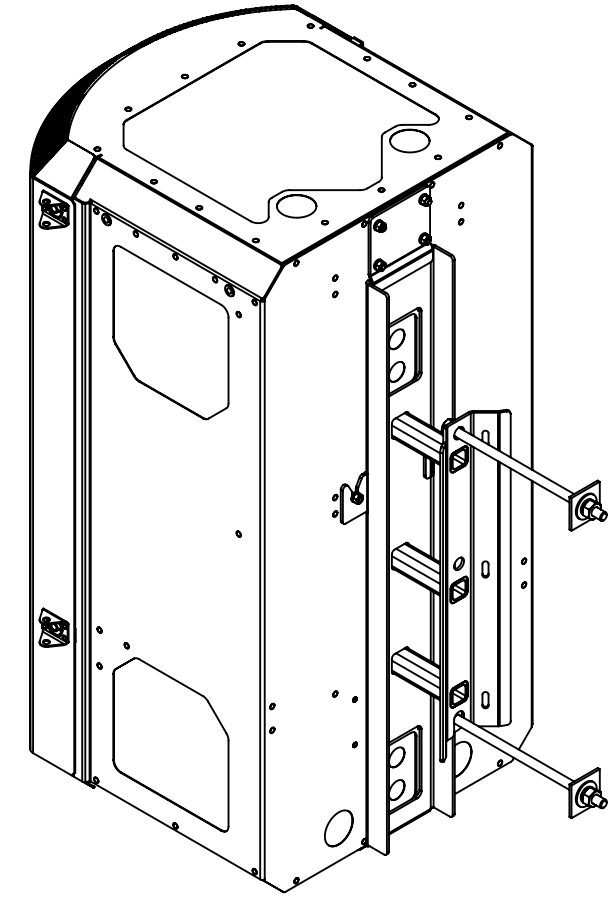

REAR ISOMETRIC VIEW

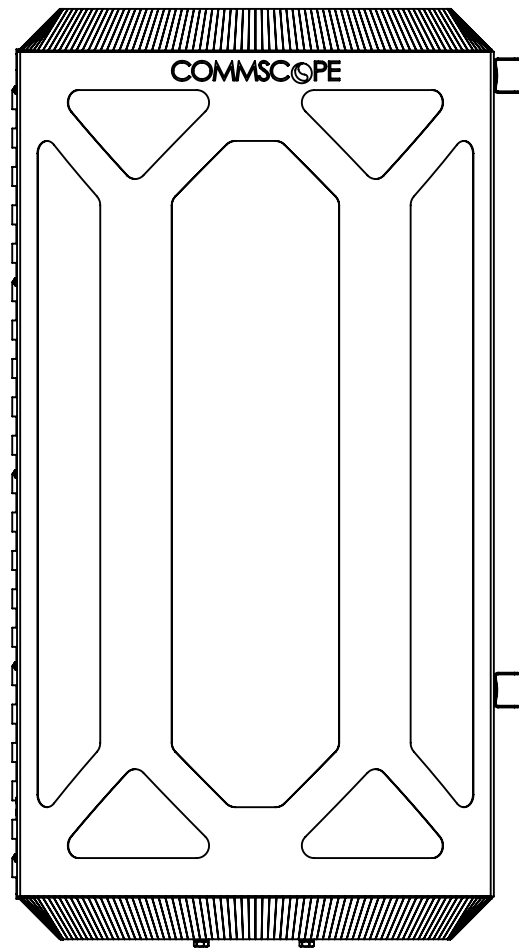

FRONT VIEW

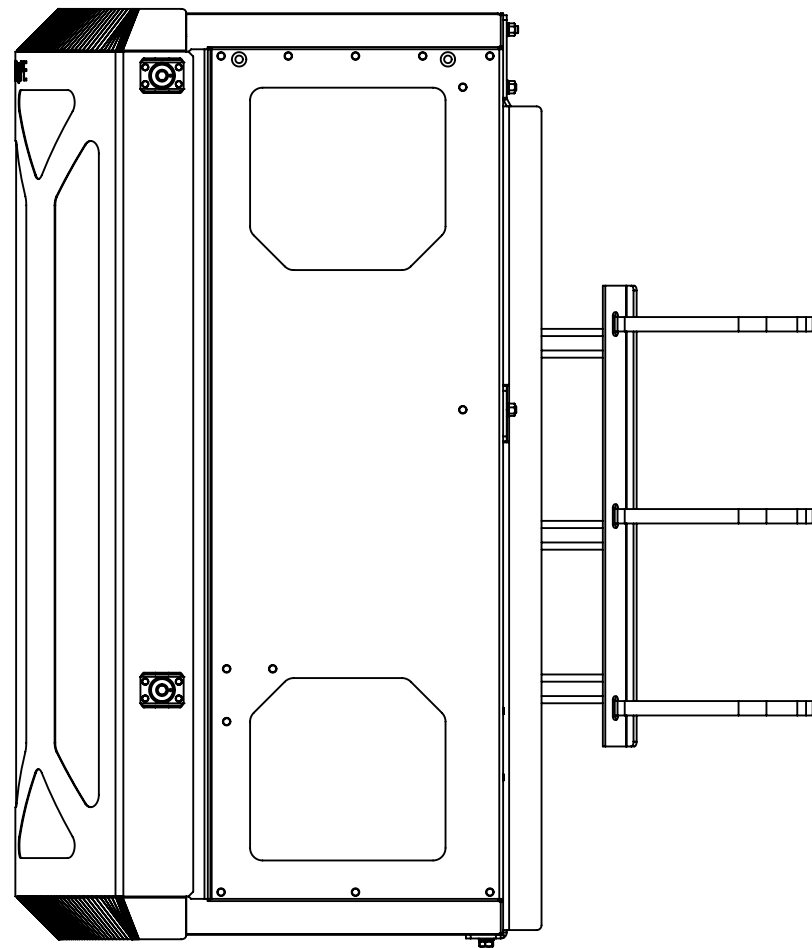

RIGHT VIEW

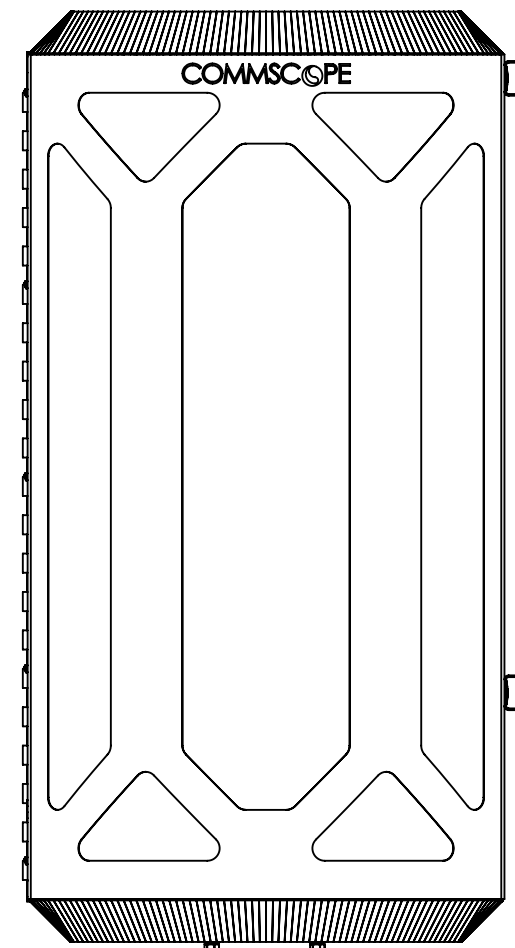

FRONT VIEW

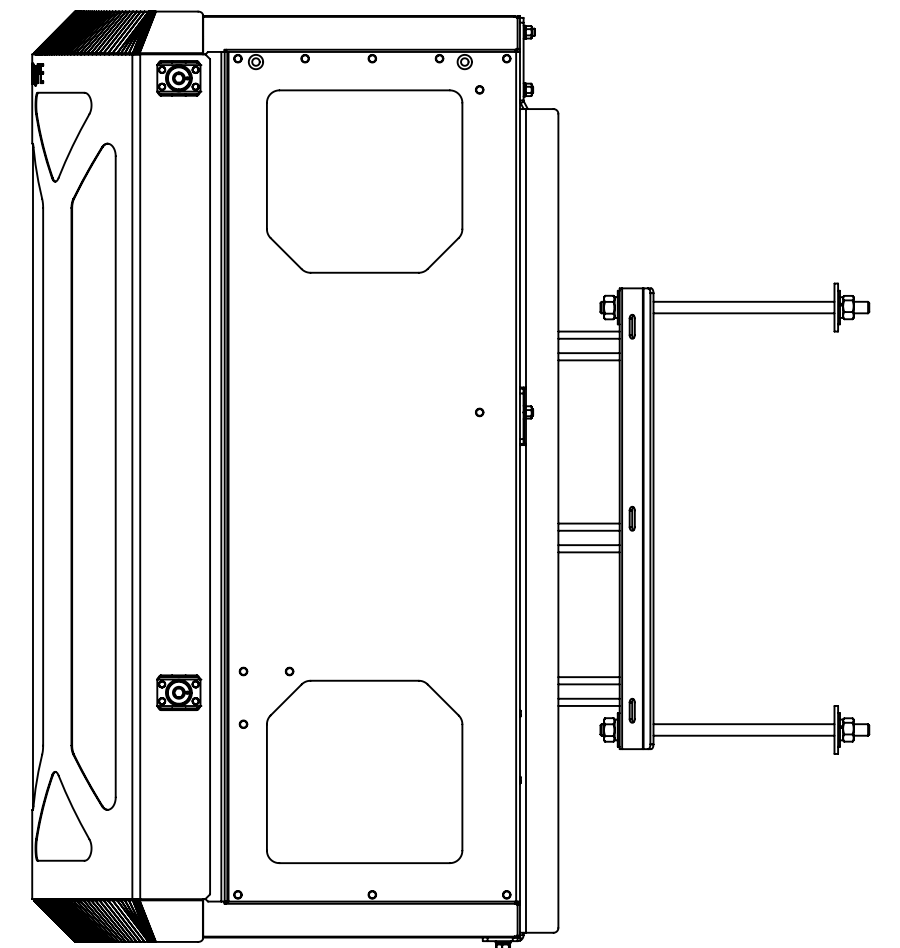

RIGHT VIEW

BAND MOUNT

THROUGH BOLT MOUNT

COMMScope, INC. OF NORTH CAROLINA

TITLE
MV2-5"-STNDOFF, WOOD-POLE

SIZE C	SCALE 1:48	DOCUMENT NO. 860661823S-XX
------------------	----------------------	-------------------------------

DRAWING	VERSION	STATUS	REVISION	SHEET 4 OF 4
	05	RE	C	

4

3

2

1