

OneCell RP5100 Line Datasheet

Version D0.7

June 3, 2020

COMMSCOPE®

OneCell Cloud RAN Small Cell System

Introduction

CommScope's OneCell enables mobile network operators to meet the growing demand for reliable LTE service where it matters most—indoors—and easily transition to 5G services when they're ready. The innovative cloud-RAN small cell architecture creates a single intelligent "super" cell inside commercial buildings and public spaces. No individual cell borders mean no handovers or interference, just high-capacity, ultra-low latency performance. OneCell deploys over standard Ethernet LANs. With OneCell, wireless operators can now meet the soaring demand for mobile data—now and in the future—while offloading traffic from their macro networks.

System Overview

The OneCell system consists of multiple **Radio Points** distributed throughout a building. They are connected via standard Ethernet switches and cabling to a centralized **Baseband Controller**. Together, the Radio Points behave as a single physical cell across the covered space.

Using joint-transmission & reception among the radio points, OneCell provides consistent coverage and high data rates across large offices and public spaces, irrespective of whether UE is under one radio point or between radio points.

Pooled baseband at the controller ensure that the capacity is available to UEs regardless if they are distributed uniformly or concentrated in specific areas (i.e. airport arrival area to departure gates).

OneCell employs Cell virtualization to dynamically sectorize the coverage area based on user location and data demand. This results in increased capacity without consuming additional spectrum resources or creating interference between users.

Indoor & Rugged radio points, powered via standard PoE (IEEE802.3at & IEEE802.3bt) and LAN (Gigabit & Multi-rate) infrastructure simplifies deployment and ensure that same single cell coverage is available indoors and adjacent outdoor spaces (i.e. bowl areas, parking lot)

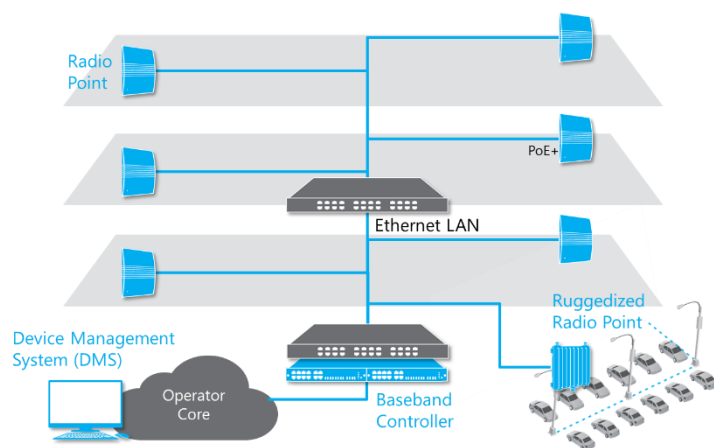

OneCell Components

Baseband controller

The Baseband Controller is responsible for performing all baseband processing, scheduling, and coordination of the transmitter and receiver functions across all Radio Points. By pooling all baseband processing and employing cell virtualization technology, it creates a single physical cell that delivers multi-sector throughput—transmit and receive—without borders, handovers or interference.



Radio Points

Radio Points transmit and receive radio frequency (RF) signals over the air and perform some layer-1 baseband processing. This edge intelligence enables advanced features such as cell virtualization, joint transmit/receive and user location awareness for emergency services. Operators can choose from two Radio Point solutions, both are available in indoor and rugged-form factors.

RP2000 Series is a highly compact, single-carrier, single-frequency solution. The frequency is software-selectable, enabling the operator to change frequency bands without touching the hardware.



RP5000 Series is a multi-carrier, multi-channel solution that supports up to four frequency bands simultaneously. It incorporates programmable logic, allowing operators deploy their LTE services today and support future modulation schemes such as 5G NR—via software upgrade.



Ethernet cabling and switches

OneCell operates on standard Gigabit and multi-rate Ethernet links and off-the-shelf Ethernet switches. As a turnkey partner, CommScope can provide all the cabling, switching and connectivity needed. This enables operators to streamline ordering, deployment and project management, saving time and money.

Device Management System (DMS)

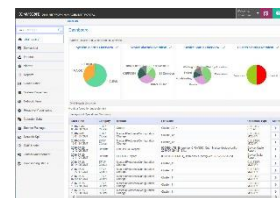

The DMS enables automated provisioning and on-going support for the OneCell solution. The DMS features an easy-to-use dashboard and can automatically configure over 100 key network and RF parameters. Its scalable architecture is capable of supporting thousands of devices.



Features and benefits:

- User-centric design: Optimizes performance based on user behaviors instead of space requirements
- Edge intelligence: Responds to changes in user location and behavior to support value-added services
- Ethernet fronthaul: Deploys as easily as Wi-Fi, using standard Ethernet cabling/switches to eliminate complex configuration and radio frequency planning
- Programmable radios: Migrates from LTE to 5G NR, CBRS and more—with a simple software upgrade
- Cell virtualization: Allows frequency sharing among users that multiplies system capacity
- Macro-/core-network friendly: Streamlines interfaces for better performance, easier deployment

Air Interface																						
Radio Modules (RM)	<ul style="list-style-type: none"> Channel Bandwidth: 5, 10, 15 & 20 MHz 2x2 MIMO One carrier per RM Band specific RM <ul style="list-style-type: none"> B1, B2, B3, B7, B66/B10/B4, B12/17, B14 Integrated antenna optimized for RM band 																					
Multi-carrier	Indoor & Rugged RP5100 Line: <ul style="list-style-type: none"> Number of Carriers/RMs: Up to 4 Indoor RP5100i models: <ul style="list-style-type: none"> Field upgradable RM. Add/Remove/Replace operation supported. 																					
Transmit Power	Indoor RP5100i models: B1/2100MHz 2x24*dBm: 20/15/10MHz CBW, 2x21 dBm: 5MHz CBW B3/1800MHz 2x24 dBm: 20/15/10MHz CBW, 2x21 dBm: 5MHz CBW B7/2600MHz 2x24 dBm: 20/15/10MHz CBW, 2x21 dBm: 5MHz CBW B2/PCS 2x24 dBm: 20/15/10MHz CBW, 2x21 dBm: 5MHz CBW B12/700MHz 2x21 dBm: 15/10/5 MHz CBW B14/700MHz 2x21 dBm: 10/5 MHz CBW B66/AWS 2x24 dBm: 20/15/10 MHz CBW, 2x21 dBm: 5MHz CBW *If 2 Band 1s are adjacent (slots 0 and 1, or slots 2 and 3) power must be reduced to 23dBm (for 10 - 20 MHz) to meet safe-touch requirement else installation must ensure 5 mm or more separation from general public at all time Rugged RP5100r models: <table border="1" style="width: 100%; border-collapse: collapse;"> <tbody> <tr> <td>B1-B3-B7</td> <td>2x20dBm, all CBW</td> <td>2 antenna ports</td> </tr> <tr> <td>B1-B3-B1-B7</td> <td>2x21dBm, all CBW</td> <td>4 antenna ports</td> </tr> <tr> <td>B2-B66-B2-B66</td> <td>2x21 dBm, all CBW</td> <td>4 antenna ports</td> </tr> <tr> <td>B2 + B12 + B14 + B66</td> <td>2x21 B2, B66, all CBW</td> <td rowspan="3">4 antenna ports</td> </tr> <tr> <td>B2 + B66 + B14</td> <td>2x18 dBm B12/B14, 10/5 MHz</td> </tr> <tr> <td>B2 + B2 + B12 + B14</td> <td>CBW</td> </tr> <tr> <td>B2 + B12</td> <td>2x21 B2</td> <td rowspan="2">2 antenna ports</td> </tr> <tr> <td>B2 + B14</td> <td>2x18 dBm B14, 5/10 MHz CBW</td> </tr> </tbody> </table> <ul style="list-style-type: none"> Factory installed diplexers 2 or 4 x 4.3-10 DIN connectors for external antennas -40C-60C operating temperature 	B1-B3-B7	2x20dBm, all CBW	2 antenna ports	B1-B3-B1-B7	2x21dBm, all CBW	4 antenna ports	B2-B66-B2-B66	2x21 dBm, all CBW	4 antenna ports	B2 + B12 + B14 + B66	2x21 B2, B66, all CBW	4 antenna ports	B2 + B66 + B14	2x18 dBm B12/B14, 10/5 MHz	B2 + B2 + B12 + B14	CBW	B2 + B12	2x21 B2	2 antenna ports	B2 + B14	2x18 dBm B14, 5/10 MHz CBW
B1-B3-B7	2x20dBm, all CBW	2 antenna ports																				
B1-B3-B1-B7	2x21dBm, all CBW	4 antenna ports																				
B2-B66-B2-B66	2x21 dBm, all CBW	4 antenna ports																				
B2 + B12 + B14 + B66	2x21 B2, B66, all CBW	4 antenna ports																				
B2 + B66 + B14	2x18 dBm B12/B14, 10/5 MHz																					
B2 + B2 + B12 + B14	CBW																					
B2 + B12	2x21 B2	2 antenna ports																				
B2 + B14	2x18 dBm B14, 5/10 MHz CBW																					
Radio Access	<ul style="list-style-type: none"> Transmission Modes; TM3, TM4 DL Modulation : QPSK, 16QAM, 64 QAM, 256 QAM UL Modulation: QPSK, 16QAM, 64 QAM 																					
Integrated antenna gain	Integrated 2x2 MIMO band specific antenna <ul style="list-style-type: none"> B3, B7, B66, B2: 3 dBi peak gain B1, B12, B4: 4 dBi peak gain 																					
Front-haul																						
Physical Interface	<ul style="list-style-type: none"> Multi-Rate Port: RJ-45 1/2.5 Gbps multi-rate IP/Ethernet (CAT5e/Cat6a/1000Base-T/2500Base-T)/PoE++ (IEEE802.3bt) Single-Rate Port: RJ-45 1 Gbps IP/Ethernet (CAT5e/Cat6a/1000Base-T)/PoE++ (IEEE802.3bt) 																					

	<ul style="list-style-type: none"> • Auto PoE++ detection
LAN/Front haul	<ul style="list-style-type: none"> • All IP Ethernet Connectivity • Baseband Controller Auto Discovery/Configuration • Maximum 4 Switch Hops between BC & RP • Cabling: Greenfield: Cat6a or better. Brownfield: Cat5e* allowed if alien cross-talk conditions met. • Cable gauge: 23AWG or lesser; Total resistive loss ≤ 100mW/meter <p><small>*Cat5e cables are not specified for alien cross talk mitigation. See TIA TSB-5021 and ISO/IEC TR 11801-9904 for guidance on using cat5e cabling for 2.5Gbps & 5Gbps applications.</small></p>
Security & Synchronization	
Security & Synchronization	<ul style="list-style-type: none"> • Secure Boot, Secure Storage (TrE) • Controller - RP Mgmt: HTTPS/SSL PSK • Fronthaul & OTA: PDCP Ciphering • IEEE1588v2 from Baseband controller
Robustness	<ul style="list-style-type: none"> • Self-healing w/Auto-Recovery • Dual Boot Image
Physical & Environmental	
Dimension	<p>Indoor RP5100i models:</p> <ul style="list-style-type: none"> ○ Ceiling, Above Ceiling, Wall, Pole, Flown Mount options ○ Size: 344.0 mm W x 344.0 mm H x 85.0 mm D / 13.54 in W x 13.54 in H x 3.35 in D ○ Weight: 3.6 KG / 7.94 lbs  <p>Rugged RP5100r models:</p> <ul style="list-style-type: none"> ○ Size: 378.7 mm W x 321.1 mm H x 102.5 mm D / 14.9in W x 12.64 in H x 4.06 in D ○ Weight: 9.85 KG / 21.7 lbs 
Environmental:	<p>Indoor RP5100i models:</p> <ul style="list-style-type: none"> • Power Requirements: IEEE802.3bt-type 4 PoE++ • Power Consumption: Up to: 72W (26W + 11.5W per RM) • Operating Temperatures: 0 to 50°C (Plenum rated: UL-2043) • Operating Humidity 10%-95% Non-Condensing • IP Rating: IP20 • MTBF: 364830 hrs @ 25C • Active Cooling/Fans, Sound Pressure Level: 39.5 dBLWAd per GR-3108 (~30.6 dBA at 1 meter) <p>Rugged RP5100r models:</p> <ul style="list-style-type: none"> • Power Requirements: IEEE802.3bt-type4 PoE++ • Power Consumption: Up to: 72W (26W + 11.5W per RM) • Operating Temperatures: -40C to 60°C without solar load • IP Rating: IP66, NEMA4 • MTBF: 495540 hrs @ 25C

Certifications	
Indoor RP5100i models	<p>Radio Equipment Directive 2014/53/EU– 3GPP Release 13 local area base station classification.</p> <ul style="list-style-type: none"> • Health: EN 50385:2002; EN 62479; EN 62311:2008 (Safe touch) • Safety: EN 62368-1:2014+ AC:2015, EN 60950:2006 + A11:2009 + A1:2010 + A12:2011 +A2: 2013/ UL-2043, 60950-1 Second Edition • EMC: EN 301 489-1 V2.2.0 (2017-03) & EN 301 489-50 V2.2.0 (2017-03) /47CFR Part 15 (CFR 47) Class A • Radio: EN 301 908-1 V11.1.1 (2016-07) & EN 301 908-14 V11.1.2 (2017-04) / FCC Part 24 & 27 (CFR 47) • Environmental: ETSI EN 300 019-2-4, Class 3.1
Rugged RP5100r models	<p>Radio Equipment Directive 2014/53/EU – 3GPP Release 13 local area base station classification.</p> <ul style="list-style-type: none"> • Health: EN 50385:2002; EN 62479; • Safety: EN 62368-1:2014+ AC:2015, EN 60950:2006 + A11:2009 + A1:2010 + A12:2011+A2: 2013 /60950-1 Second Edition • EMC: EN 301 489-1 V2.2.0 (2017-03) & EN 301 489-50 V2.2.0 (2017-03)/ 47CFR Part 15 (CFR 47) Class A • Radio: EN 301 908-1 V11.1.1 (2016-07) & EN 301 908-14 V11.1.2 (2017-04)/ FCC Part 24 & 27 (CFR 47) • Environmental: ETSI EN 300 019-2-4, Class4.1E, IP66, NEMA4

CommScope (NASDAQ: COMM) helps companies around the world design, build and manage their wired and wireless networks. Our network infrastructure solutions help customers increase bandwidth; maximize existing capacity; improve network performance and availability; increase energy efficiency; and simplify technology migration. You will find our solutions in the largest buildings, venues and outdoor spaces; in data centers and buildings of all shapes, sizes and complexity; at wireless cell sites and in cable headends; and in airports, trains, and tunnels. Vital networks around the world run on CommScope solutions.



250 Apollo Drive
 Chelmsford, MA 01824 USA
 +1 (978) 250-3000
www.commscope.com

CommScope, OneCell and their respective logos are trademarks of CommScope. This document is for informational and planning purposes only and it is subject to change, error and omission. Not all features are available in all releases or product configurations.