

NOTES:

| REVISIONS | | | |
|-----------|---|-------------|----------|
| REV. | DESCRIPTION | DATE | APPROVED |
| A | ECR 8000037172: REL TO PRODUCTION PER EAO 607253. | 09NOV19 XHX | CHF/REX |
| B | ECR 8000039779: UPDATE DRAWING WITH LATEST MODEL. | 19MAR20 XHX | CHF/REX |

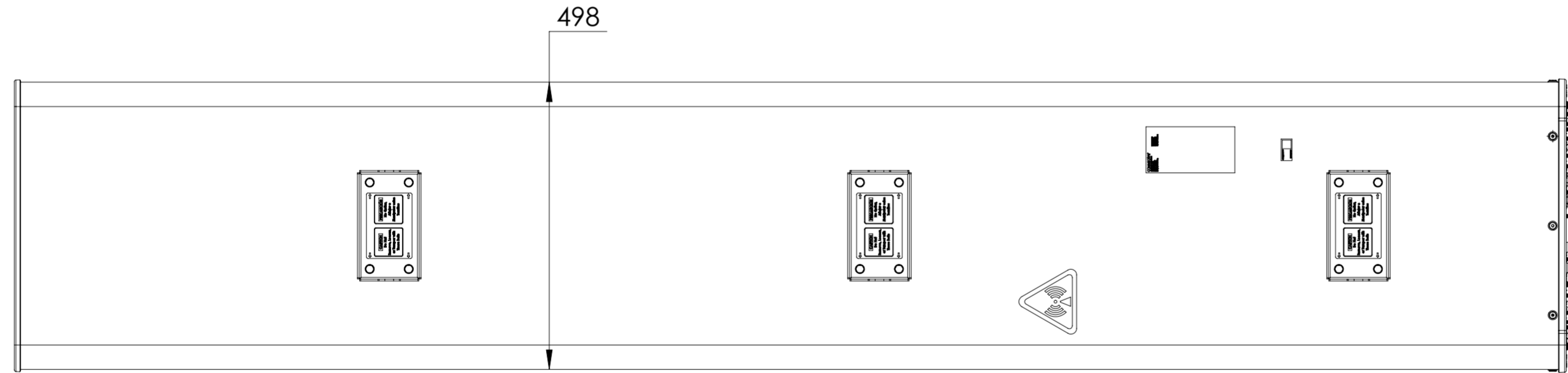
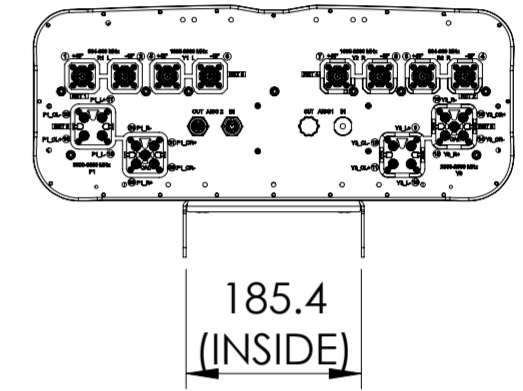
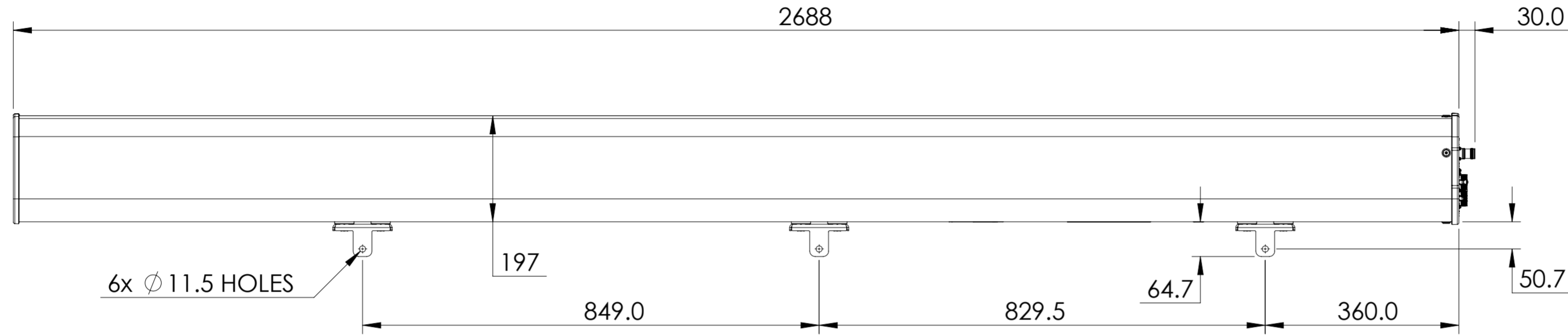

RRVVT4S4-65D-R6

| COMMSCOPE, INC. OF NORTH CAROLINA | | | | | | | | | | | | | | | | | | | | | |
|---|--|-----------|---------------|-------------------|--|---------------------|--|--------|----------|----------|--|--------|--|------------|--|-----------------|--|--|--|--|--|
| TOLERANCES | | | | | | SAP MATERIAL MASTER | | | | | | | | | | | | | | | |
| 0 PLACE X ± | | | 2 PLACE .XX ± | | | 1 PLACE .X ± | | | ANGLES ± | | | | | | | | | | | | |
| FINISH | | | | | | MATERIAL | | | | | | | | | | | | | | | |
| <small>UNLESS OTHERWISE SPECIFIED DIMENSIONS ARE IN MILLIMETERS INTERPRET PER ISO STANDARDS HANDBOOK TECHNICAL DRAWINGS VOLUMES 1 & 2, THIRD EDITION (2002)</small> | | | | | | | | | | | | | | | | | | | | | |
| | | | | | | | | | | | | NAME | | DATE | | TITLE | | | | | |
| | | | | | | | | | | | | HX1004 | | 11/09/2019 | | PRODUCT DRAWING | | | | | |
| | | | | | | | | | | | | RW | | | | | | | | | |
| | | | | | | | | | | | | AD | | | | | | | | | |
| RE | | | | SCALE | | DOCUMENT NO. | | | | | | | | | | | | | | | |
| ECN 8000039779-0 | | 1:8 | | RRVVT4S4-65D-R6-L | | | | | | | | | | | | | | | | | |
| SIZE | | WORK AREA | | MODEL | | DRAWING | | | | SHEET | | | | | | | | | | | |
| A2 | | 23 | | | | VERSION | | STATUS | | REVISION | | | | | | | | | | | |
| | | | | | | 01 | | RE | | B | | | | | | | | | | | |
| | | | | | | 01 | | RE | | B | | | | | | | | | | | |
| | | | | | | | | | | 1 OF 1 | | | | | | | | | | | |

| | |
|--------------|-------------------|
| DENSITY | g/mm ³ |
| MASS | Kg |
| VOLUME | mm ³ |
| SURFACE AREA | mm ² |
| HEIGHT | |
| LENGTH | |
| WIDTH | |

© 2019 CommScope, Inc.