

Mini Pod Installation Guidelines

1.0 General Assembly.

Determine how incoming cables will be grouped & managed entering the enclosure, the enclosure has provision to mount a 32mm (max.) gland/conduit fixing - **not** supplied. Assemble socket to LJ6C adaptor and insert into cover as shown.

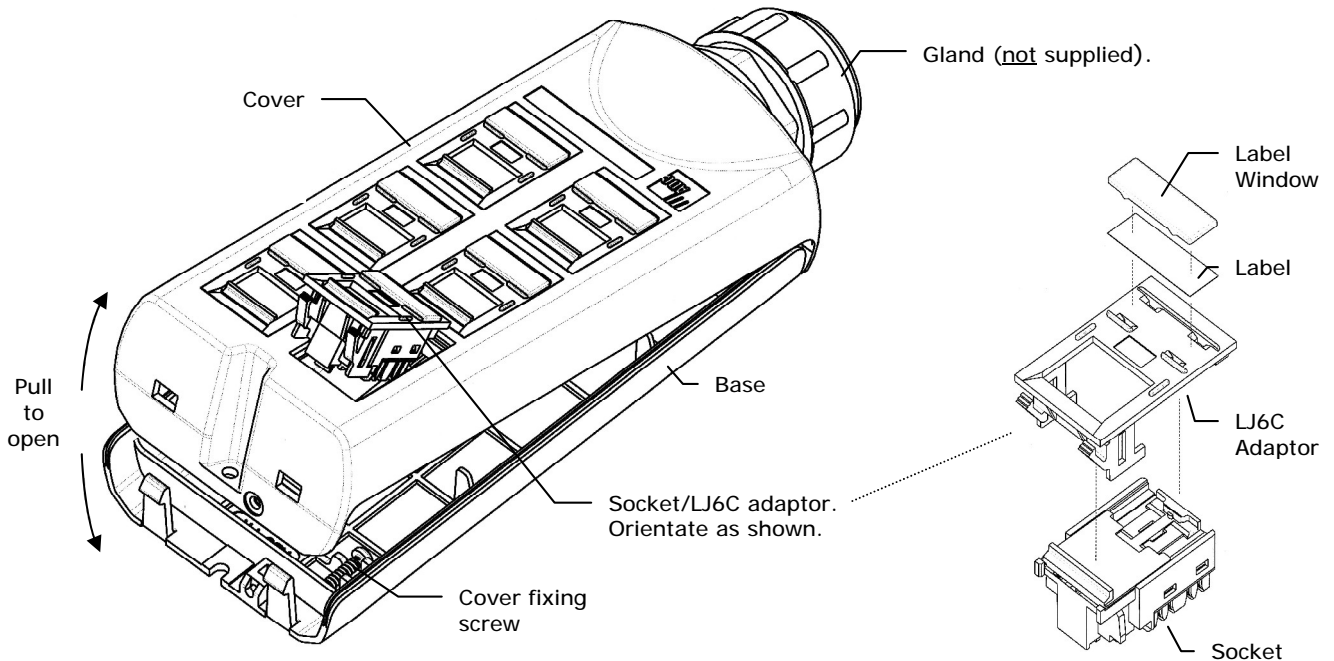

Surface Mount Consideration.

Select relevant surface mount option (1 or 2). Appropriate fixings (**not** supplied) should be used to mount the enclosure to a surface - surfaces must be secure, clean and flat. Max fixing screw size - No. 8, do **not** use countersunk style screws.

If using external mount option (1) assembly of cover fixing screw is optional.

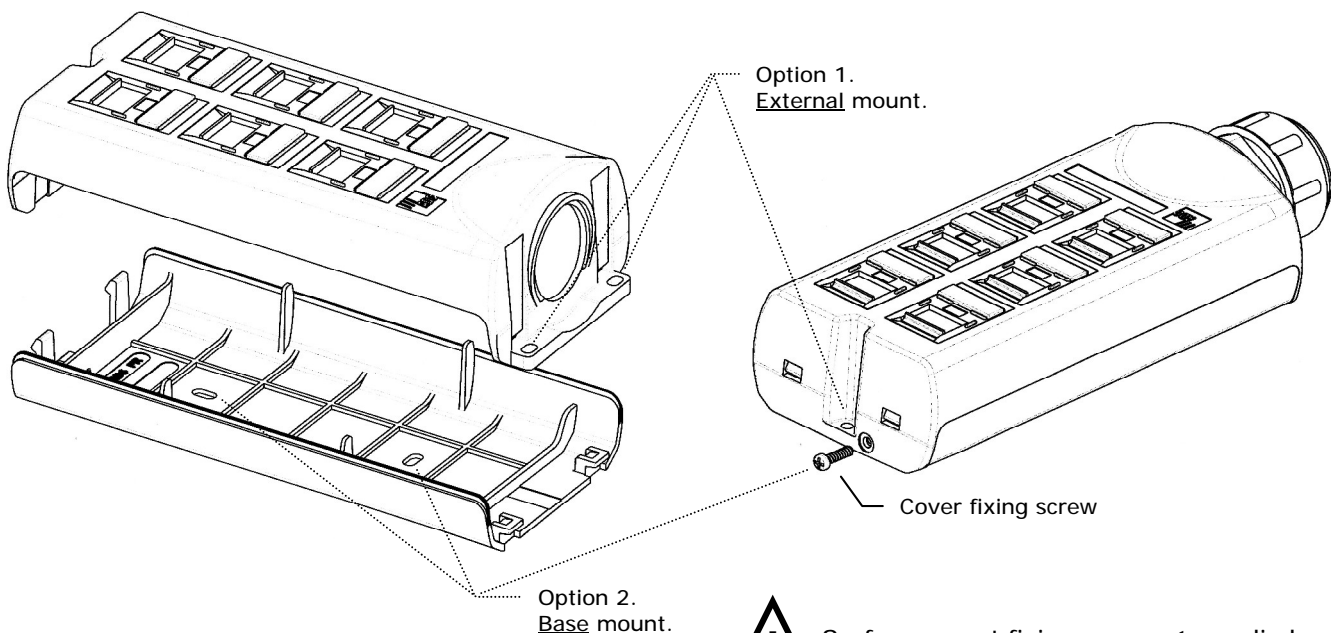

Surface mount fixings are **not** supplied

2.0 Installation

Terminate socket following instructions provided. If required sockets can be terminated while assembled to the cover, in this instance assemble and terminate sockets nearest cable entry position first and work backwards. Replace cover and secure enclosure as described in 1.0.

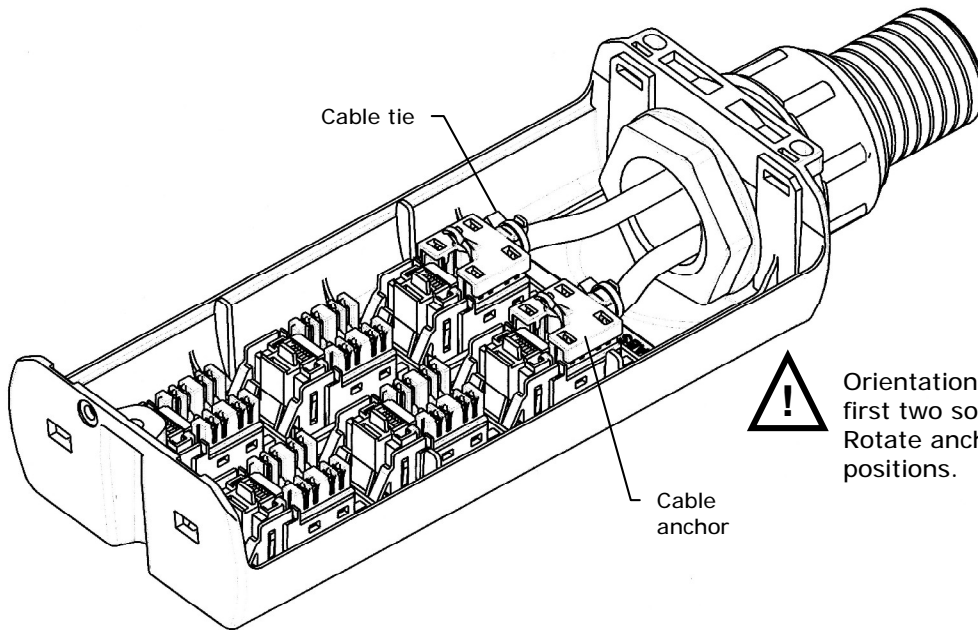

Orientation of cable anchor differs for first two socket positions (as shown). Rotate anchor 180° for remaining positions.

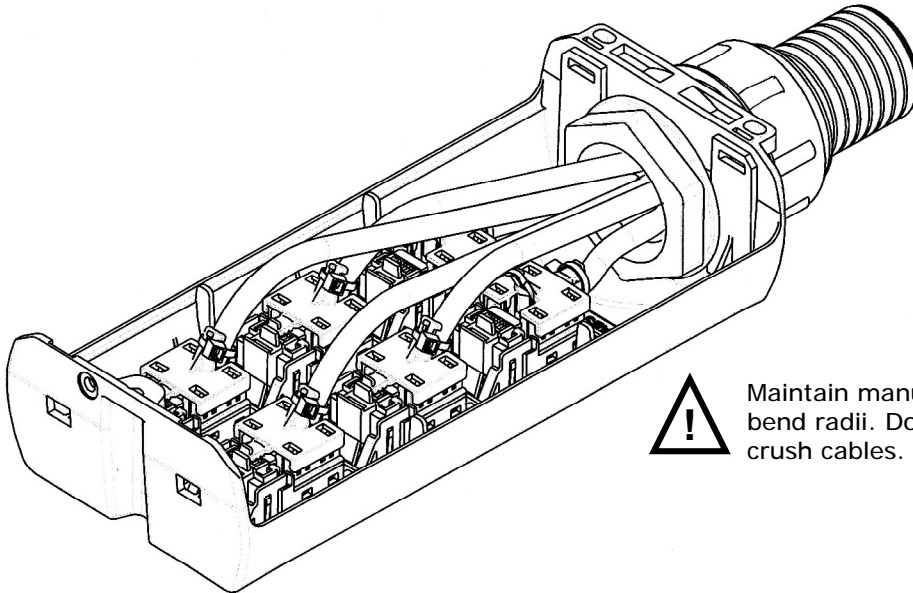

Maintain manufacturers recommended cable bend radii. Do not over-tighten cable ties or crush cables.

ADC Communications (UK) LTD
Running RD
Kingsditch Trading Estate
Cheltenham.
Glos.
Telephone +44 (01242) 264400
Fax +44 (01242) 264488
Email contactuk@adckrone.com

ADC Krone reserves the right to change design details without giving notice