

**INSTALLATION
INSTRUCTIONS**

Right Angle Connectors

for HELIAX® LDF4-50A or LDF4-75A
Foam-dielectric Coaxial Cable



Description

These connectors are designed for connector-flaring of the outer conductor and soldering of the inner connector to the inner conductor of the coaxial cable.

Tools and Materials Required for Assembly

- | | |
|----------------------------|--|
| Scale | Wrenches: Two 13/16" and one 9/16" |
| Knife | Solvent: comothene, vythene, or other nonflammable cleaning fluid |
| Flat file | Garnet cloth, 240 grit or finer |
| Wire brush | Solder, 63/37 RMA flux core |
| Damp cloth | Soldering iron, min. 150 W: |
| Spacing gauge (supplied) | a resistance-type iron is recommended when soldering in low-temperature environments |
| Silicone grease (supplied) | Fine-toothed hacksaw or jeweler's saw |

Notice

The installation, maintenance or removal of antenna systems requires qualified, experienced personnel. Andrew installation instructions have been written for such personnel. Antenna systems should be inspected once a year by qualified personnel to verify proper installation, maintenance and condition of equipment.

Andrew disclaims any liability or responsibility for the results of improper or unsafe installation practices.

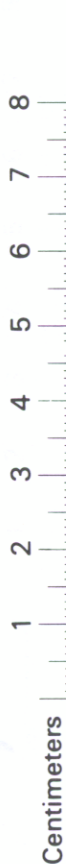
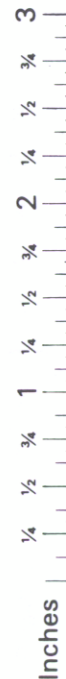
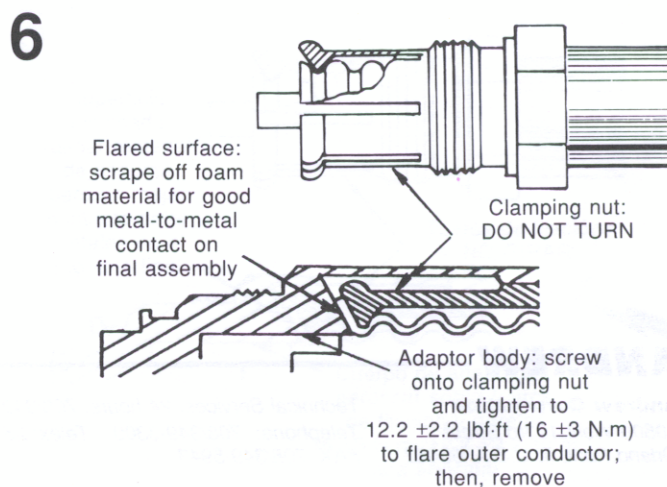
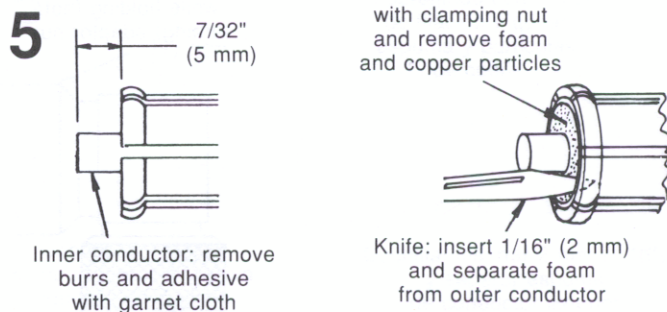
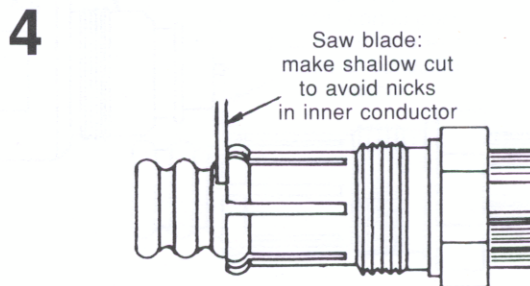
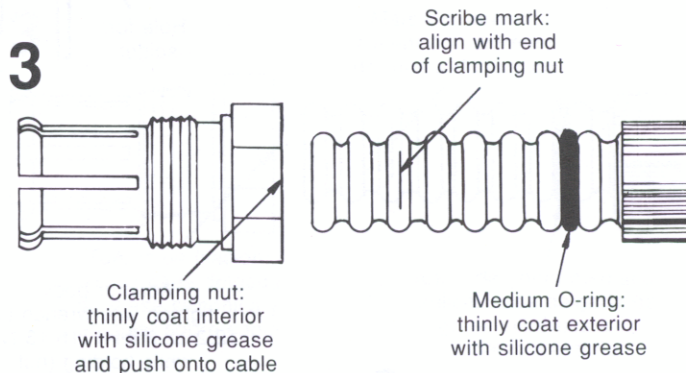
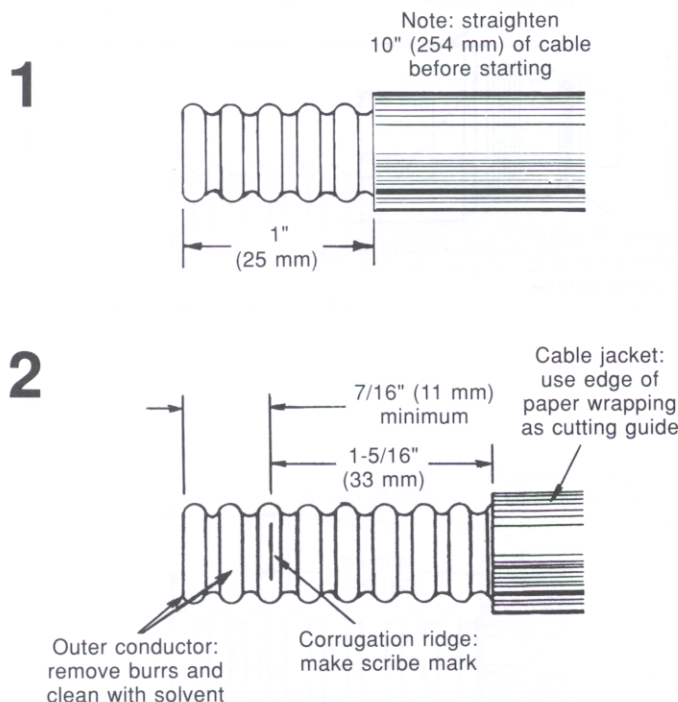

7

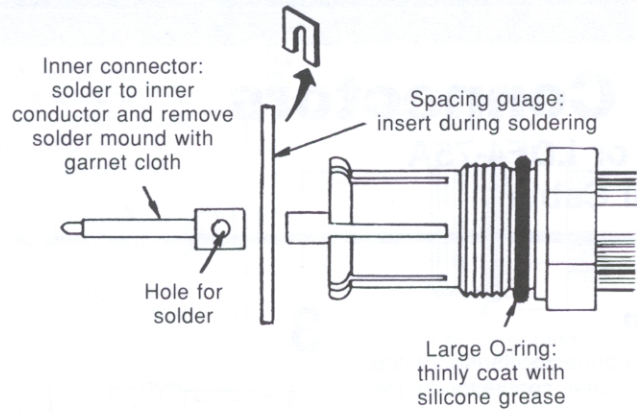

8

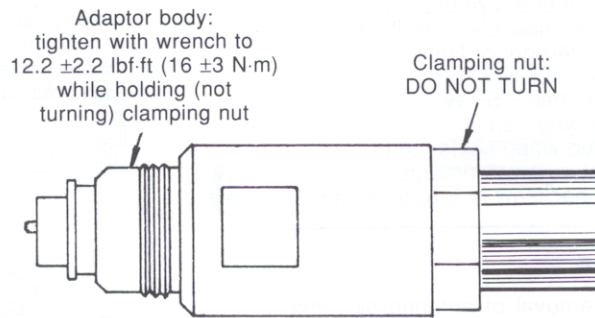

9

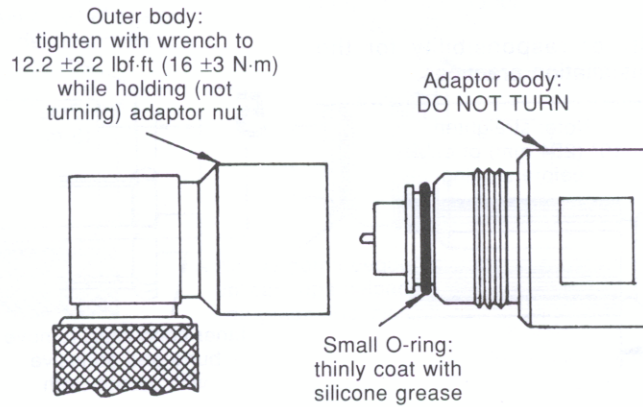

**INSTRUCCIONES
DE INSTALACION**

Conectores en ángulo recto para cables coaxiales de dieléctrico de espuma HELIAX® LDF4-50A ó LDF4-75A



Descripción

Se han diseñado estos conectores de modo que se pueda abocinar el conductor exterior y soldar el conector interno al conductor interior del cable coaxial.

**Herramientas y materiales requeridos
para el montaje**

Regla, escala	Llaves de tuerca: dos de 20,5 mm (13/16") y una de 25,4 mm (1")
Cuchilla	Solvente: comothene, vythene u otro líquido
Lima plana	limpiador no inflamable
Cepillo de alambre	Jerga, arenilla 240 ó más fina
Trapo húmedo	Soldadura, 63/37 RMA con núcleo de fundente
Roldana espaciadora (se suministra)	Cautín, mín. 150 W: se recomienda uno del tipo de resistencia para soldar en ambientes de baja temperatura
Grasa silicónica (se suministra)	Segueta de diente fino o sierra de modelador

Advertencia

Se requiere que la instalación, el mantenimiento o el retiro de los sistemas de antenas sea efectuado por personal calificado y con experiencia. Las instrucciones de instalación de Andrew se han escrito pensando en esta clase de personal. Se deben inspeccionar los sistemas de antenas una vez al año utilizando personal calificado a fin de verificar si la instalación, el mantenimiento y la condición del equipo son adecuados.

Andrew no asume ninguna responsabilidad ni obligación resultante de las prácticas de instalación incorrectas o inseguras.

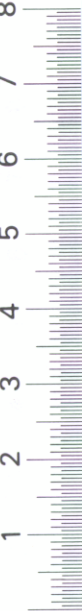
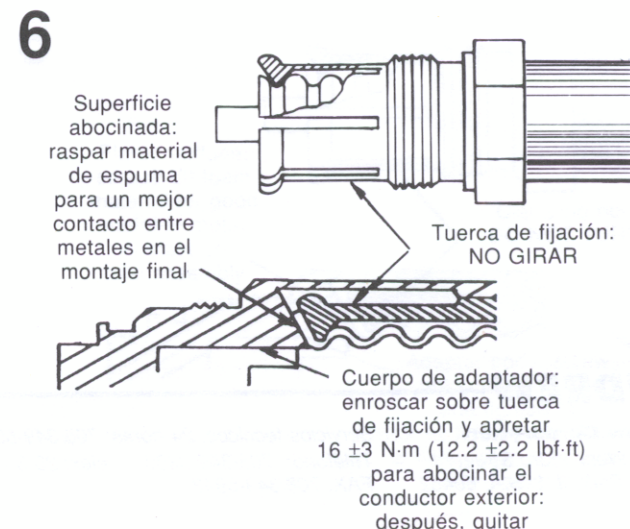
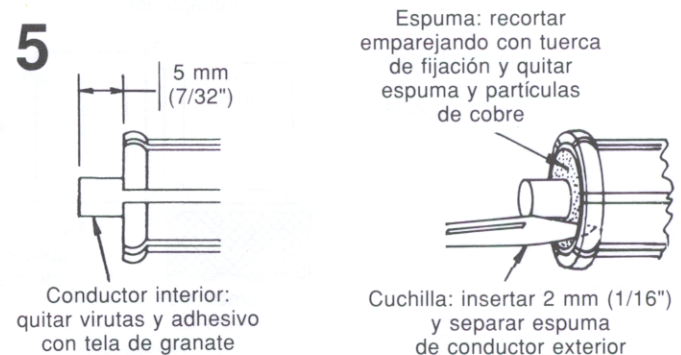
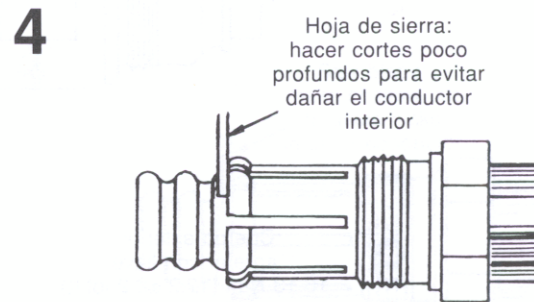
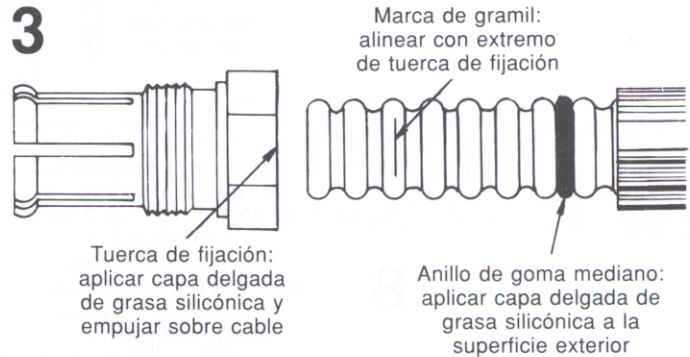
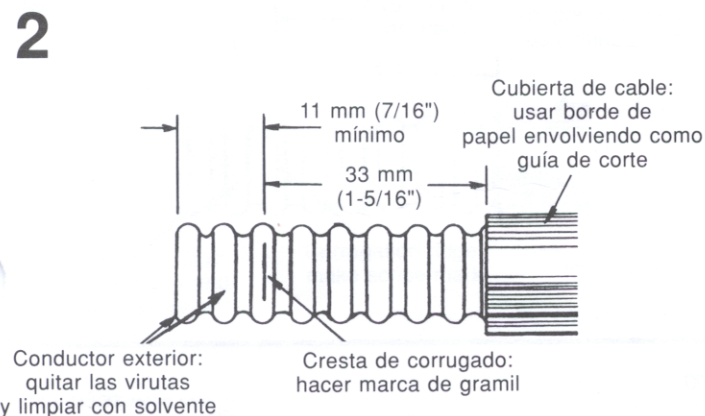
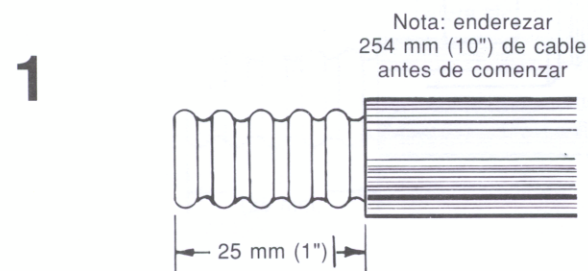

7

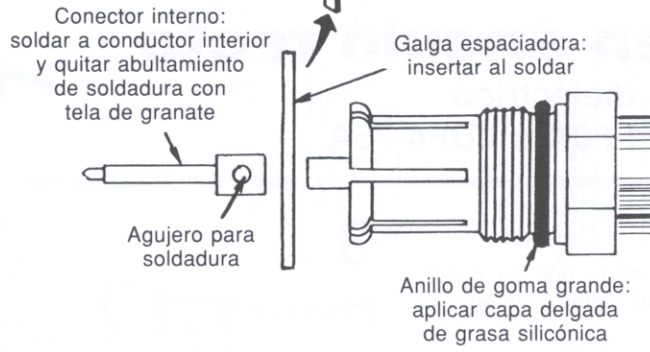

8

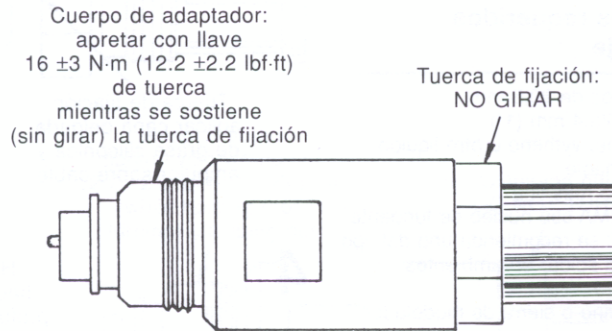

9

