

REV	MCO	DWN	DATE
C	20246204	JM	08-AUG-08
D	BNS_CD_BRAND	GG	10-FEB-17

NOTES:

1.0 SCOPE

THIS SPECIFICATION DEFINES THE REQUIREMENTS FOR A WALL PLATE MODULAR 12 PORT ASSY VARIOUS COLORS

2.0 APPLICABLE DOCUMENTS

- 2.1 UL 94 "TESTS FOR FLAMMABILITY OF PLASTIC MATERIALS"
- 2.2 ORDER OF PRECEDENCE

IN CASE OF CONFLICT, THE FOLLOWING ORDER OF PRECEDENCE SHALL APPLY:
 A. PURCHASE ORDER
 B. THIS DOCUMENT

3.0 REQUIREMENTS

- 3.1 MATERIALS
 - 3.1.1 MATERIAL: ABS POLYLAC PA-765A OR EQUIVALENT.
 - 3.1.2 COLOR: SEE TAB
- 3.2 DIMENSIONAL
 - 3.2.1 SEE DRAWING
 - 3.2.2 PART TO BE FREE OF BURRS, SCRATCHES, SPOTS AND NOTICEABLE SINK.
- 3.3 FLAMMABILITY:
 - 3.3.1 FLAMMABILITY RATING: MATERIAL USED SHALL BE UL94 V-0 LISTED.
- 3.4 MARKING AND MOLDING:
 - 3.4.1 CLASSIFIED U.S. UL LOGO, CLASSIFIED CANADA UL LOGO, UP ARROW DIRECTION, CATALOG NUMBER AND ADC LOGO, SHOULD BE MOLDED INSIDE THE FACE PLATE.

4.0 QUALITY ASSURANCE PROVISIONS:

- 4.1 MANUFACTURING INSPECTION:
THE MANUFACTURER SHALL PREFORM AUDITS TO ENSURE 100% FUNCTIONALITY OF ALL RECEIVED PARTS. ADDITIONAL TESTING AND INSPECTIONS SHALL BE PREFORMED AS NEEDED TO ENSURE THAT ALL REQUIREMENTS ARE MET.
- 4.2 QUALITY CONFORMANCE INSPECTION
BUYER RESERVES THE RIGHT TO RETURN AT THE MANUFACTURER'S EXPENSE ANY NONCONFORMING MATERIALS OR LOTS WHICH DO NOT MEET SAMPLING INSPECTION REQUIREMENTS.
- 4.3 DESIGN AND PROCESS CHANGE:
NO CHANGES IN MATERIAL DESIGN OR PROCESS WHICH WILL AFFECT FORM, FIT OR FUNCTION SHALL BE MADE BY THE MANUFACTURER AFTER SAMPLE APPROVAL WITHOUT WRITTEN AUTHORITY FORM THE BUYER. THE TERM "FUNCTIONAL" IMPLIES SECTION 3.0 PARAMETERS.

5.0 PACKAGING AND HANDLING REQUIREMENTS:

- 5.1 MAXIMUM CONTAINER WEIGHT: 40 LBS.
- 5.2 SHIPPING CONTAINER MARKING(S)

SHIPPING CONTAINERS SHALL BE MARKED WITH THE FOLLOWING AS A MINIMUM:

- 1. MANUFACTURER'S NAME AND/OR LOGO
- 2. ADC PART NUMBER
- 3. ADC PURCHASE ORDER NUMBER
- 4. QUANTITY ENCLOSED
- 5. (PREFERRED BUT OPTIONAL INFORMATION):
NUMBER OF SEPARATE PACKAGES/BOXES
("BOX# ---- OF ---- BOXES")

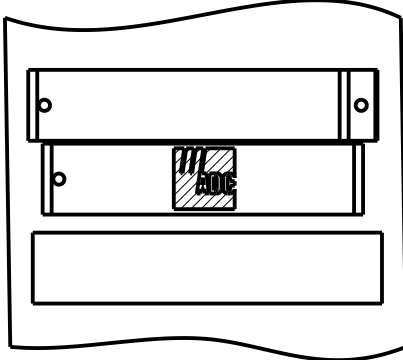
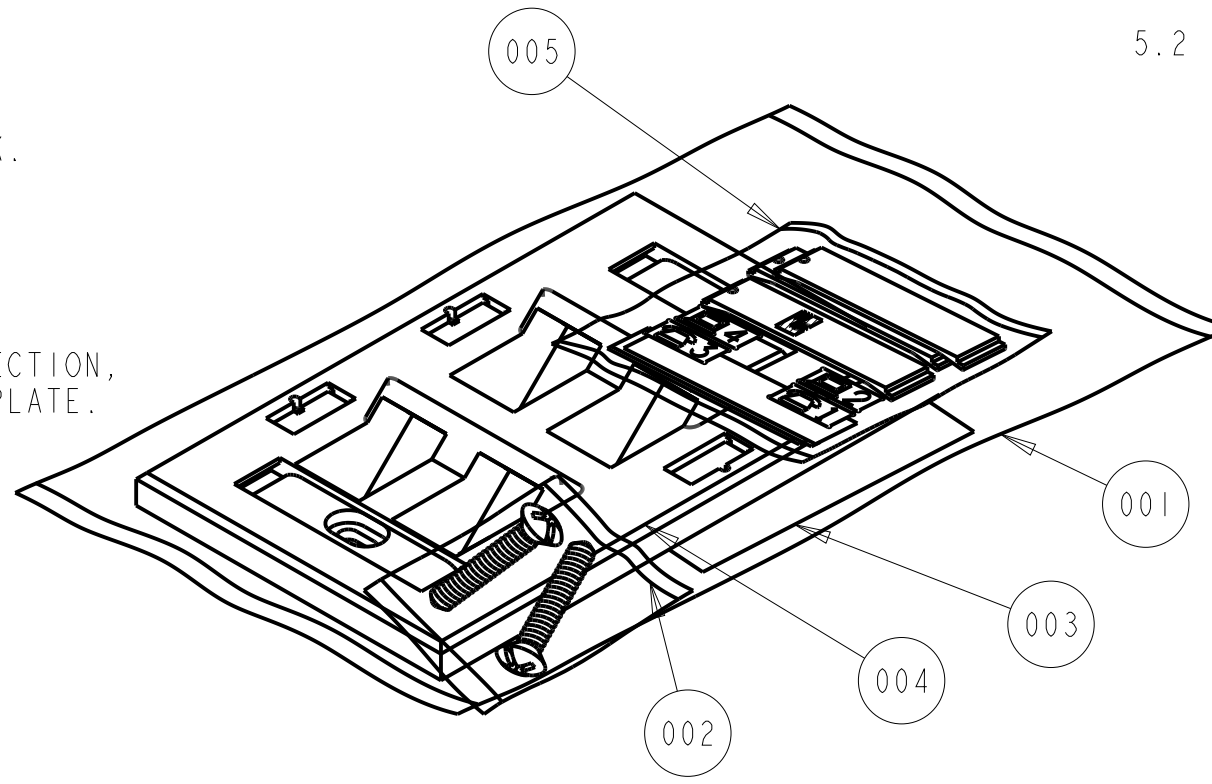

F/N 005 DETAIL

ADC P/N	CATALOG	REV	COMPONENT F/N 002 (DESCRIPTION) QTY 2	COMPONENT F/N 003 INST SHT 4 PORT ANGLED PLATE (COLOR) QTY 1	COMPONENT F/N 004 FACEPLATE, ANGLED MODULAR 4 PORT (COLOR) QTY 1	PANTONE COLOR	FEDERAL STANDAR SPECIFICATION	COMPONENT F/N 005 POLYBAG ID TABS & DESIGNATION (COLOR) QTY 1
6644117401	6644 I 174-01	C	6630 3 105-00 POLYBAG W/2 #6 - 32x15/16 COMBO SCREWS	1436426	6644 3 174-01 (WHITE)	---	FED STD. 37925	6630 3 116-01 (WHITE)
6644117402	6644 I 174-02	C			6644 3 174-02 (IVORY)	---	FED STD. 27886	6630 3 116-02 (IVORY)
6644117403	6644 I 174-03	C			6644 3 174-03 (GRAY)	421C	FED STD. 25630	6630 3 116-03 (GRAY)
6644117404	6644 I 174-04	C			6644 3 174-04 (BLACK)	6C2X	FED STD 27038	6630 3 116-04 (BLACK)
6644117413	6644 I 174-13	C			6644 3 174-13 (GRAPHITE)	---	---	6630 3 116-13 (GRAPHITE)
6644117414	6644 I 174-14	C			6644 3 174-14 (CHARCOAL)	---	---	6630 3 116-14 (CHARCOAL)
6644117422	6644 I 174-22	C			6644 3 174-22 (ELECTRIC IVORY)	4545U	---	6630 3 116-22 (ELECTRIC IVORY)

NOTES:

1. USE POLYBAG CLEAR F/N 001 4 X 7 IN 0.002 THICK FOR PACKAGE ALL THESE COMPONENTS;
IT SHOULD BE SEALED AT BOTH ENDS

COMMSCOPE, INC.

© 2016 COMMSCOPE, INC. CONFIDENTIAL
 NOTICE: THESE DRAWINGS AND SPECIFICATIONS ARE THE PROPRIETARY PROPERTY OF COMMSCOPE, INC. AND MAY BE USED ONLY FOR THE SPECIFIC PURPOSE AUTHORIZED IN WRITING BY COMMSCOPE, INC.

TITLE ASSY FACEPLATE MODULAR ANGLED 4 PORT

ALL DIMS AND TOLERANCES .XX:±N/A ARE INCHES UNLESS .XXX:±N/A OTHERWISE SPECIFIED ANGULAR:±N/A

SIZE C DRAWING NUMBER 66441174XX_ADC D REV

DO NOT SCALE DRAWING

ENGR: T.J. PICKLES SHT. 1 OF 1
DWN: T.J. PICKLES