



EMEA Floor Box Instructions

General

The 600 x 600 floor box is intended for use with industry standard 24 inch x 24 inch (600mm x 600mm) raised floor systems used in information technology (IT) and data center environments. The floor box allows up to 8U of equipment to be installed beneath the raised floor. A separately orderable cover is available for the floor box.

Ordering Information is listed below:

Material ID	Part No.	Description
760161661	600x600-FLOOR-BOX-EMEA	Floor box assembly

How to Contact Us

- To find out more about **CommScope®** products, visit us on the web at <http://www.commscope.com/>
- For technical assistance:
 - Within the United States, contact your local account representative or technical support at 1-800-344-0223. Outside the United States, contact your local account representative or Authorized Business Partner.
 - Within the United States, report any missing/damaged parts or any other issues to **CommScope** Customer Claims at 1-866-539-2795. Outside the United States, contact your local account representative or Authorized Business Partner.

Tools Required

- Sheet metal snips
- Adjustable wrench
- Screwdriver
- Hex wrench

Parts List

Verify parts against the parts list below:

Quantity	Description
1	Floor box assembly
4	Support bracket with mounting screws
4	Bracket mounting clamp
12	Cable aperture grommet
8	M6 screws
16	M6 nuts
1	Instruction sheet

Separately Orderable Parts

Material ID	Part No.	Description
760115782	TOP-PAN-BRUSH-REAR-EMEA	Cable aperture brush entry
760115766	TOP-BLK-PANEL-EMEA	Cable aperture blanking panel
760161679	600x600-FLOOR-BOX-COVER-EMEA	Floor box cover

Minimum Raised Floor Requirements

Verify the minimum dimensions of the raised floor panels as shown. The required minimum raised floor depth is 10 inches (255mm).

Note: At the minimum floor depth, the supplied support brackets do not need to be fitted.

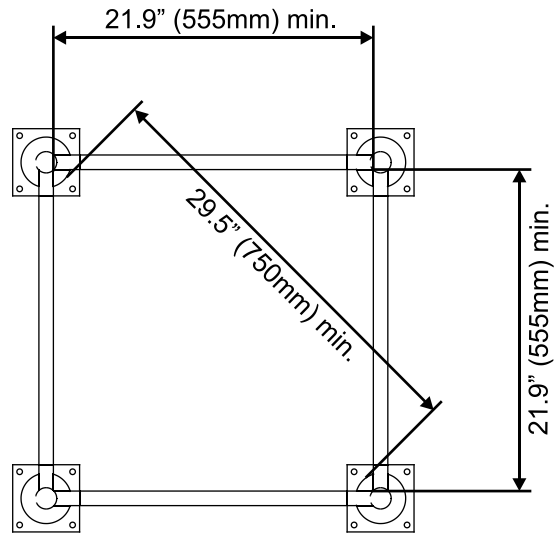

Step 1 – Install Support Brackets

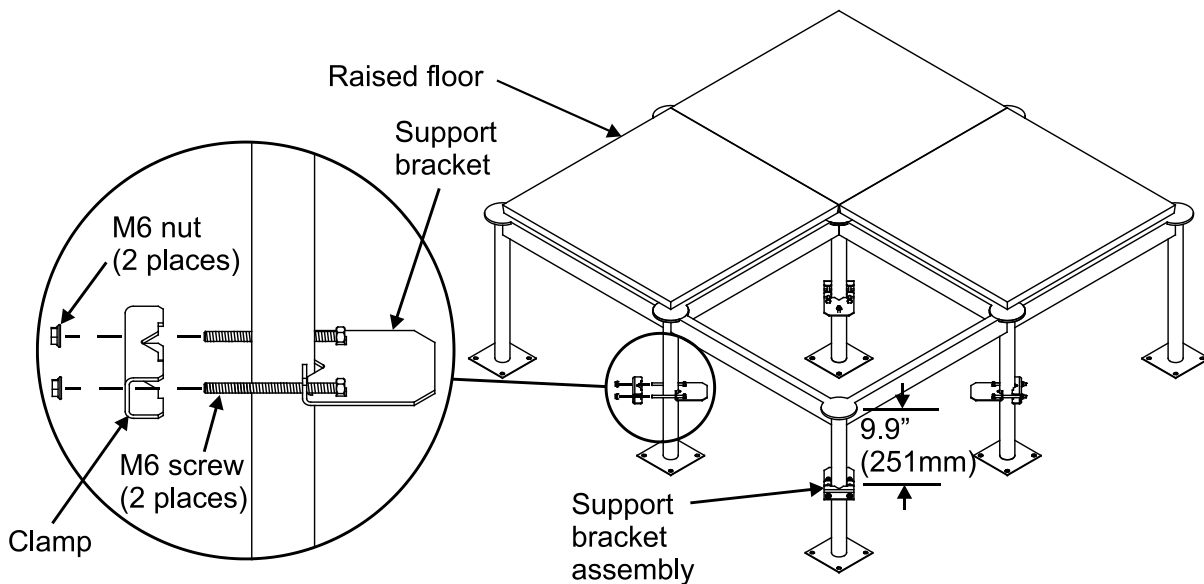

1. Remove floor tile in location where floor box will be mounted.
2. Assemble and attach four support bracket assemblies 9.9 inches (251mm) below the top of floor stringers as shown above.

Step 2 – Install Floor Box

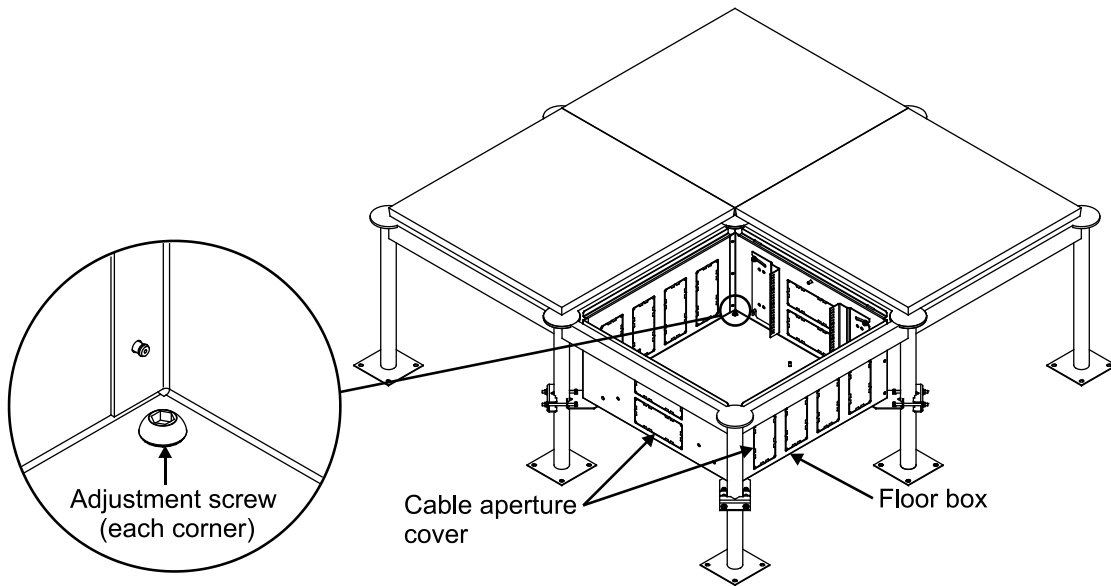

Note: Planning and organizing equipment to be installed in floor box prior to completing box installation will be beneficial. Equipment mounting rails in box can be angled or adjusted to accommodate different size equipment. See Steps 3 and 4 for instructions before completing box installation.

1. Remove required cable aperture covers from floor box using sheet metal snips or similar tool. This should be done before fitting floor box into raised floor.
2. Position floor box on support brackets as shown above.
3. Use four adjustment screws in bottom of the floor box to level box with top of floor stringers.
4. Fit provided grommet strips to all cable apertures removed previously.
5. Install equipment in floor box and replace floor tile.

Step 3 – Adjust Angle of Equipment Mounting Rails

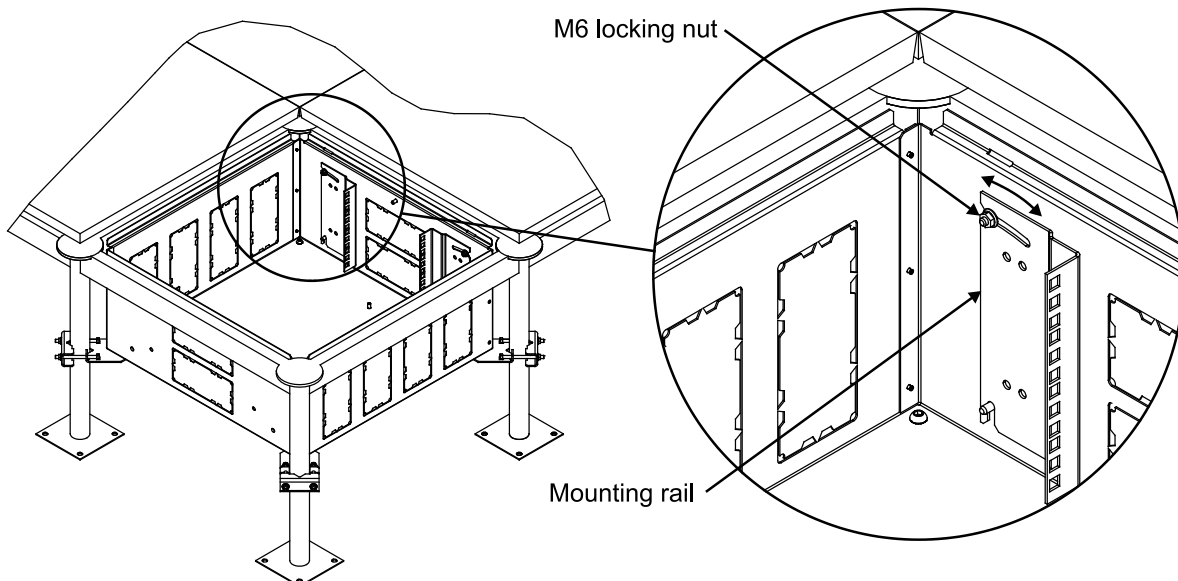

1. To change the angle of equipment mounting rails, loosen the M6 locking nut on each rail as shown.
2. Adjust angle of both rails the same and retighten locking nuts to secure mounting rails to sides of floor box.

Step 4 – Reposition Mounting Rails

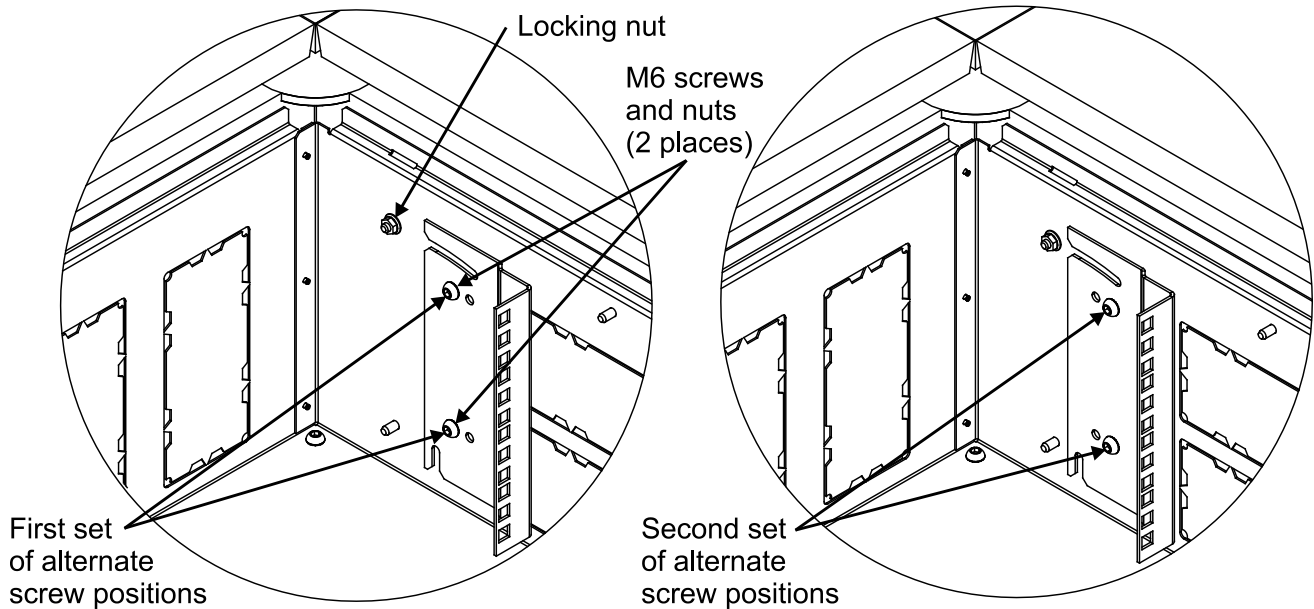

Note: Using M6 screws and nuts provided, the equipment mounting rails may be repositioned to suit deeper equipment. This must be done prior to installing the floor box into the raised floor.

1. Loosen M6 locking nut on each mounting rail as shown.
2. Move rails to alternate position as shown and secure to sides of floor box in either one of two sets of alternate holes using the two M6 screws and nuts provided.
3. Tighten screws and nuts to secure mounting rails.

Step 5 – Install Optional Cover on Floor Box

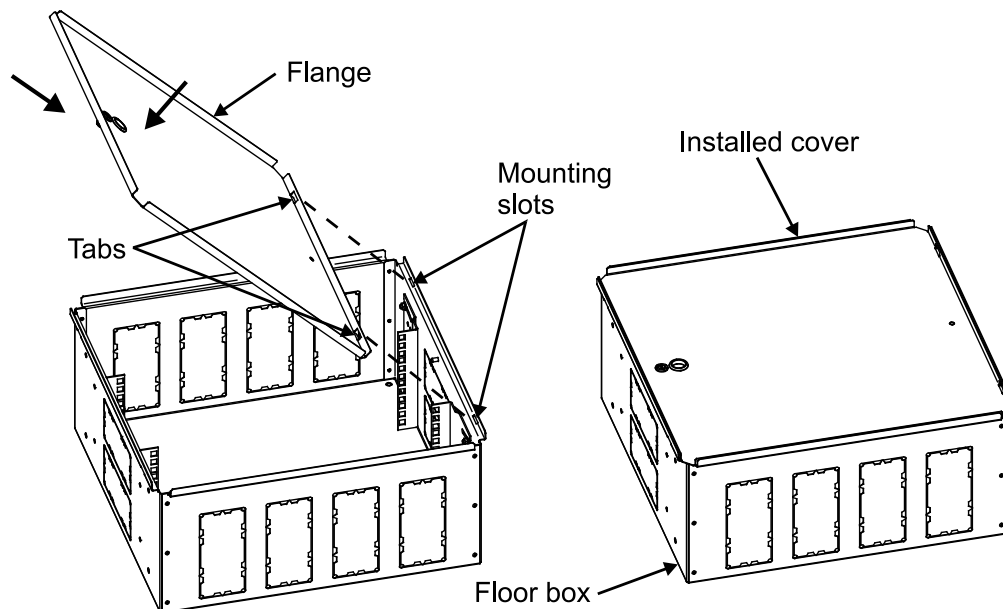

1. Position cover with flanges pointed up and tabs aligned with two mounting slots in floor box.
2. Insert cover tabs into floor box slots and lower cover down on box. The cover flanges should fit inside of the box flanges.