

LGX®-Compatible (LSX) Preterminated Termination/Splice Panel With Pigtails

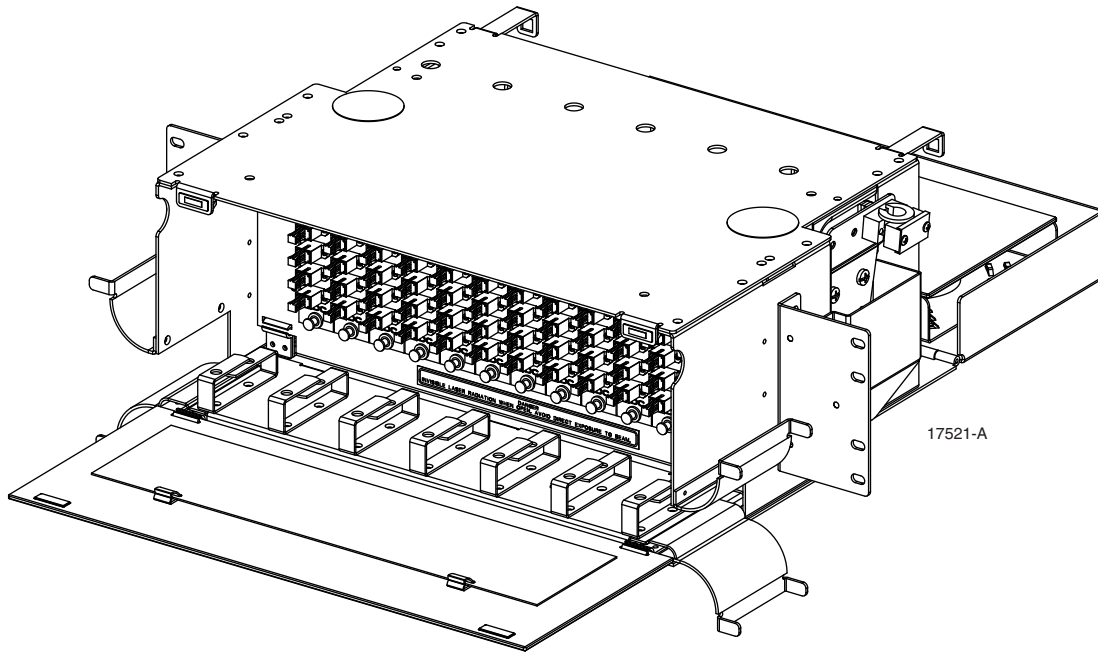

Content	Page
INTRODUCTION	2
1 DESCRIPTION	2
2 DIMENSIONS	6
3 SPECIFICATIONS	8
4 UNPACKING THE PRODUCT	9
5 INSTALLATION	9
5.1 Installing the Combination Module	9
5.2 Grounding an Armored Cable	10
5.3 Breaking Out a Cable for Splicing	11
5.4 Installing a Cable Clamp	12
5.5 Feeder Cable Routing	15
5.5.1 Cable Routing for 7-Inch and 9-Inch High Panels	16
5.5.2 Cable Routing for 1.75 Inch High Panels	17
5.5.3 Cable Routing for 3.5 Inch High Panels	18
6 PATCH CORD ROUTING	19
6.1 Patch Cord Routing Within the LSX Module	19
6.2 Routing Patch Cords on the LGX Bay	20

(Continued)

Content (continued)	Page
6.2.1 Cross-Connecting Within a Stand-Alone Bay	20
6.2.2 Cross-Connecting Between Adjacent Bays	22
6.2.3 Cross-Connecting to Non-Adjacent Bays	23
6.2.4 Routing Patch Cords Starting in the Lower Raceway	24
6.2.5 Routing Patch Cords Starting in the Upper Raceway	26
6.3 Mounting 144-Position Modules Adjacent to 72 or 96 Position Modules	28
7 OPERATION	28
7.1 Removing a Cover for Easier Access	28
7.2 Patching and Testing	28
8 CUSTOMER INFORMATION AND ASSISTANCE	30

INTRODUCTION

This user manual describes the CommScope LGX Compatible (LSX) Preterminated Termination/Splice Panel With Pigtails, and provides instructions for installation and operation.

Revision History

ISSUE	DATE	REASON FOR CHANGE
Issue 1	05/2002	Original.
Rev B	April 2018	Changed to CommScope format.

Trademark Information

LGX and CommScope are trademarks.

Related Publications

(<http://www.commscope.com/SupportCenter>)

Title	ADCP Number
LGX-Compatible (LSX) 288-Position Termination/Splice Panel User Manual	93-103
LGX-Compatible (LSX) Connector Module User Manual	93-089
Armored Plenum Compact Building Cable Ground Clamp Kit (GND-STPKIT) Installation Instructions	90-382

1 DESCRIPTION

The LSX Preterminated Termination/Splice Panel With Pigtails is an LGX style, rack-mounted panel that provides a splicing transition between one or more fiber optic cables and a termination bulkhead for fiber optic patch cords.

In a typical application, the LSX panel serves as a splicing and distribution point to transition from Outside Plant (OSP) or Intra Facility Cable (IFC) to inbuilding circuits connected to with patch cords. The panel may be used in either an interconnect or cross-connect configuration, and in either singlemode or multimode applications.

Figure 1 summarizes the functional components of the LSX termination panel. As shown, an OSP or IFC cable is routed through the panel to the splice area access door, which serves as a splice deck. On the splice area rear access door, located on the rear of the panel, the component fibers are spliced to the internal pigtailed. The factory-terminated internal pigtailed transition to the bulkhead, located on the front of the panel. Patch cords installed from the front side of the panel provide the connection to fiber optic terminal equipment.

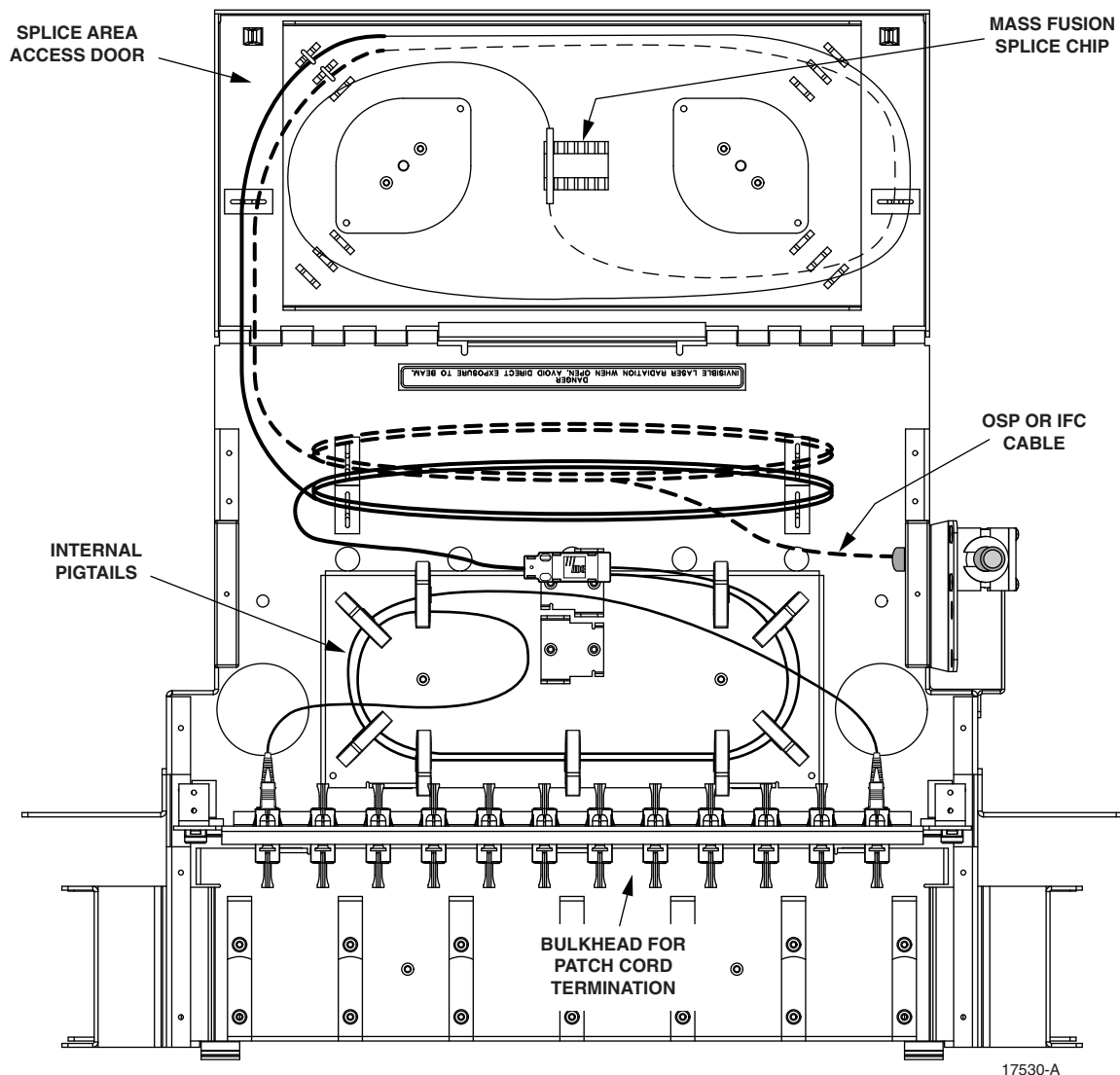

Figure 1. Functional Components of LSX Preterminated Termination/Splice Panel (Cut-Away Top View)

The LSX panel is shipped with pre-terminated, factory-installed ribbon or stranded pigtails. The panel is available in five chassis heights with different numbers of termination positions, as follows: 1.75-inch high with 12 or 24 termination positions; 3.5-inch high with 48 termination positions; 7-inch high with 72 or 96 positions; 9-inch high with 144 positions; and 11-inch high with 288 positions (documented in a separate manual). [Figure 2](#) shows the main external features of the 7-inch high panel. The 1.75-inch, 3.5-inch, and 9-inch high panels have analogous features.

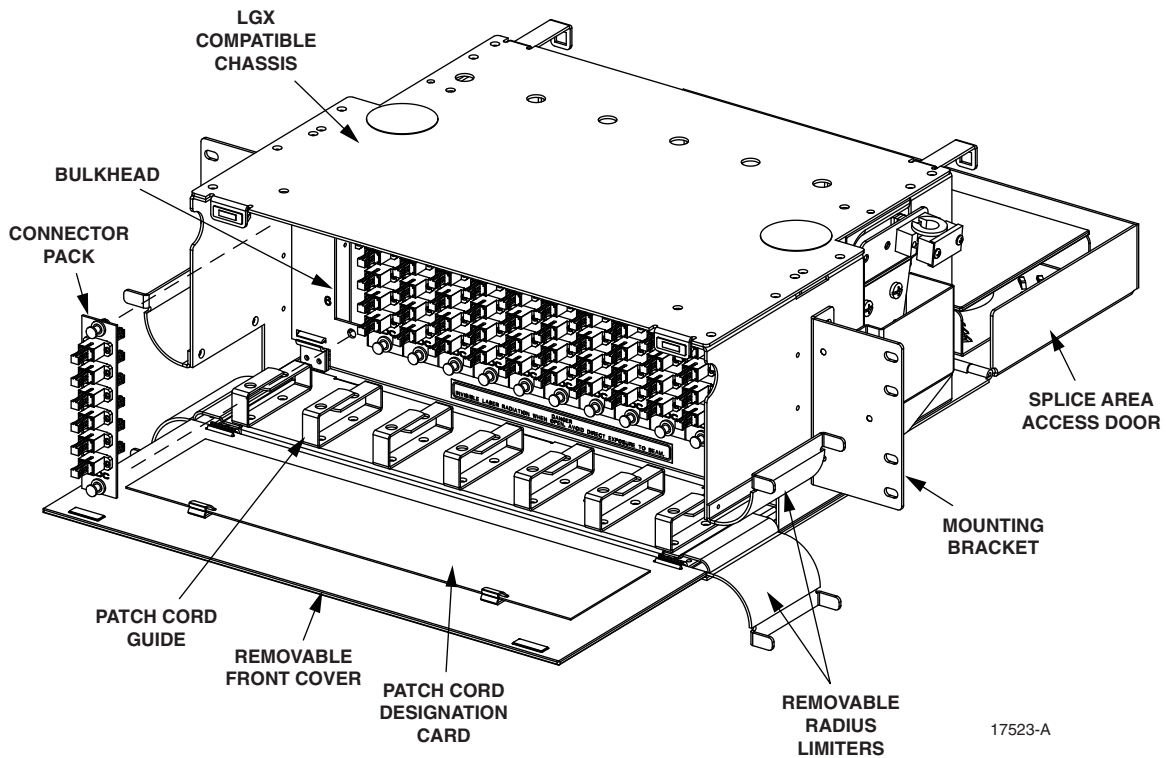

Figure 2. Main External Features of 7-Inch High LSX Termination/Splice Panel (Front View)

The features shown are as follows (see [Figure 2](#)):

- **LGX-Compatible Chassis**—is of solid metal construction and painted white. Nine 7-inch chassis or seven 9-inch chassis may be installed on an LGX frame.
- **Bulkhead**—holds the pass-through adapters that provide the physical interface between the connector ends of internal pigtails and patch cords installed on the bulkhead.
- **Adapter Pack**—6-, 8-, 12- or 24-pack depending on model; mounts in the bulkhead providing one column of adapters/connectors for terminating patch cords. Connector types available include singlemode USC, ASC, and UFC, and multimode SC.
- **Patch Cord Guides**—provide cable management in routing patch cords.
- **Removable Front Cover**—provides unimpeded access for installation of patch cords.
- **Patch Cord Designation Card**—is used to record patch cord usage.
- **Removable Radius Limiter**—provides bend radius protection for the fibers.

- **Mounting Brackets**—may be oriented for either 19-inch or 23-inch rack mount.

Every LSX Termination/Splice Panel has a rear splice area such as shown in [Figure 3](#) for the 7-inch panel. The other height panels have analogous features.

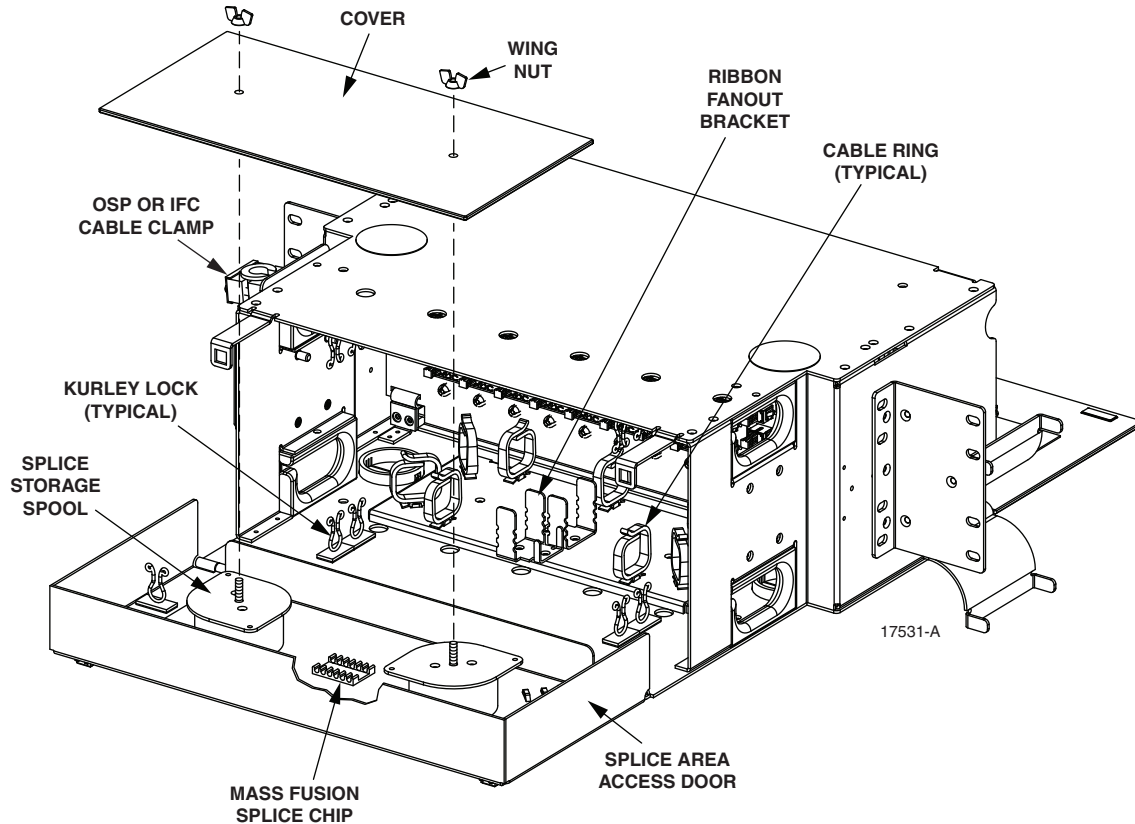

Figure 3. LSX Termination/Splice Panel (Rear View)

The main features in the rear splice area are as follows:

- **OSP or IFC Cable Clamp**—secures cable to chassis.
- **Kurley Locks**—route and secure cable fibers and internal pigtails.
- **Splice Storage Spools**—provides service loop storage for cable fibers and pigtails.
- **Mass Fusion Splice Chip**—splices 24 fiber/pigtail interfaces.
- **Splice Area Access Door**—folds down providing a horizontal splice deck.
- **Cable Ring**—routes and secures cable on entry into splice area.
- **Ribbon Fanout Bracket**—holds one stack of four ribbon fanout chips (if ribbon rather than stranded pigtails are present).
- **Wing Nut**—secures the cover (next item) to hold it in place.
- **Cover**—protects splices once completed.

Each panel is shipped with a cable clamp.

2 DIMENSIONS

Figure 4 shows dimensions for the most common chassis heights, 7-inch and 9-inch. Figure 5 shows dimensions for 1.75-inch high panel. Figure 6 shows the 3.75-inch high panel.

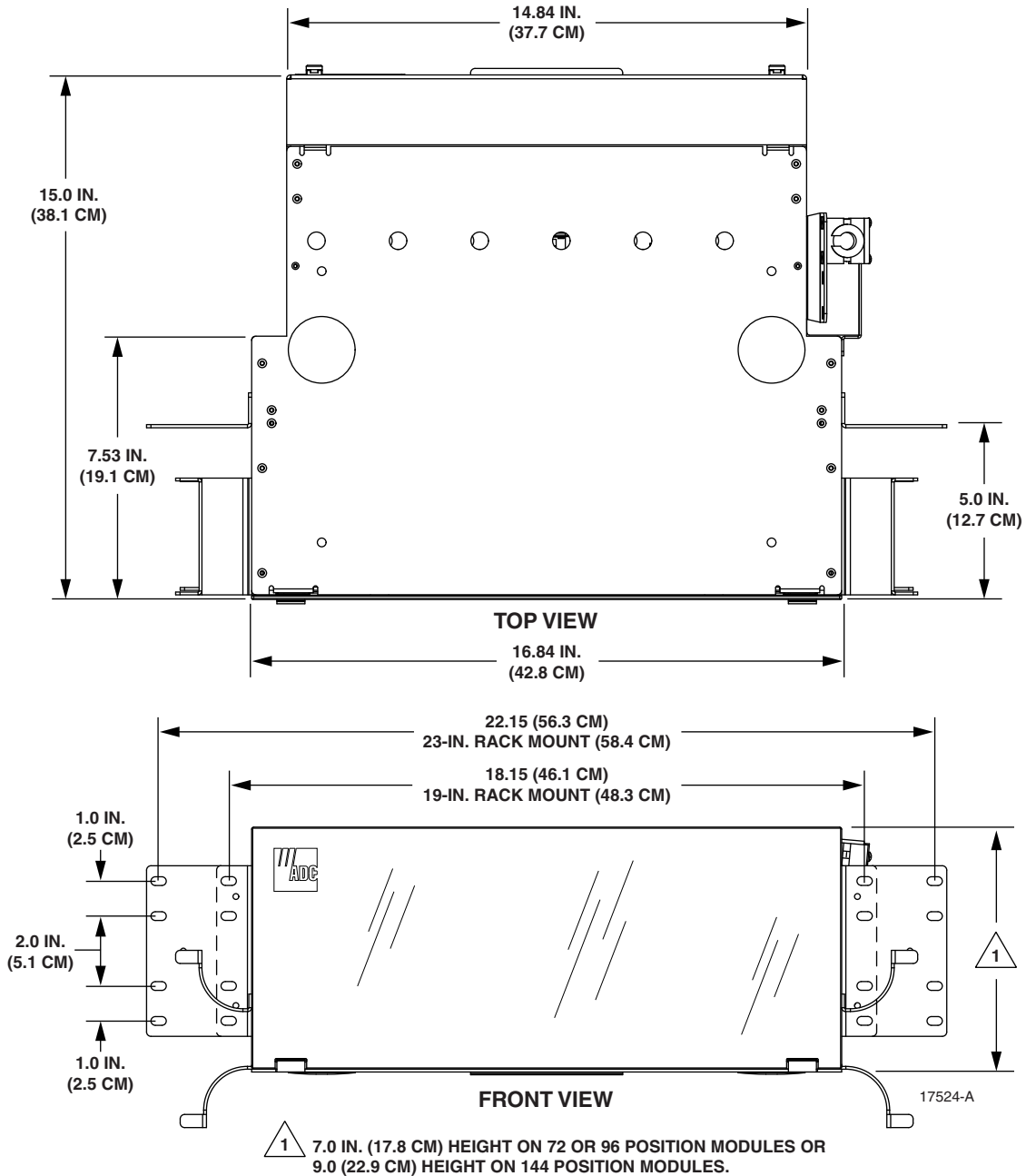

Figure 4. Dimensions for 7-Inch and 9-Inch High Panel

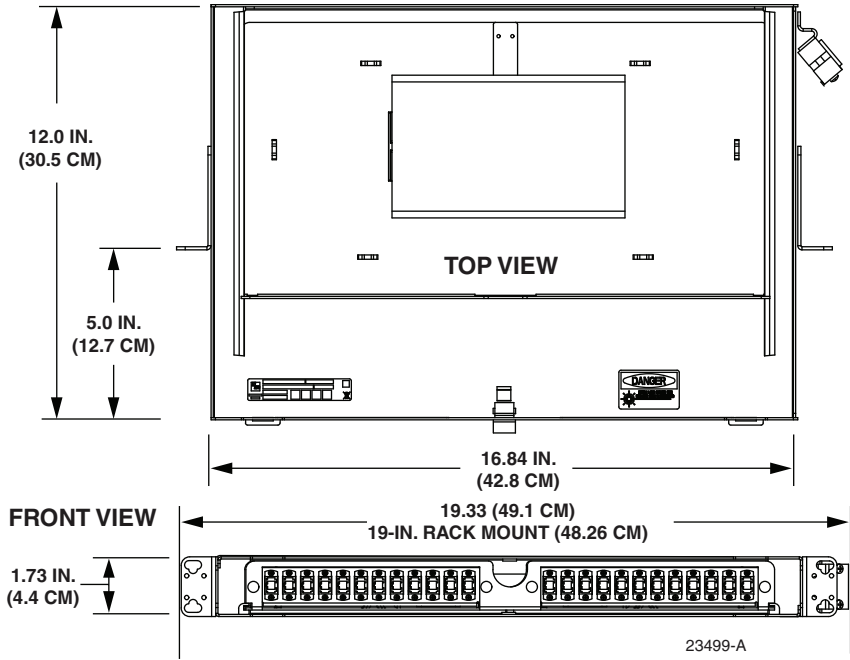

Figure 5. Dimensions for 1.75-inch High Panel

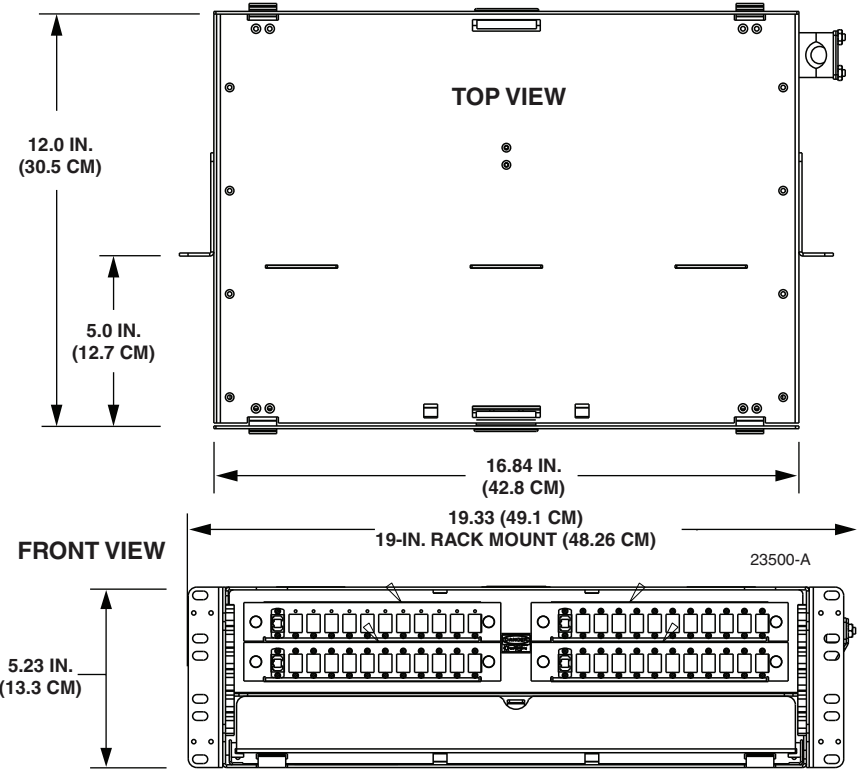

Figure 6. Dimensions for 3.50-inch High Panel

3 SPECIFICATIONS

Table 1 lists specifications for the LSX panel.

Table 1. LSX Combination Module Specifications

PARAMETER	SPECIFICATION	REMARKS
General		
Color	Putty white	
Rack mounting	19- or 23-inch	EIA or WECO hole spacing
Connector Types	Singlemode ASC, USC, UFC Multimode USC	
7-Inch High Panel		
Number of Terminations	72 or 96	
Dimensions (HxWxD)	7.0 x 17.0 x 12.0 inches (17.8 x 435 x 281.7 mm)	See Figure 4
Weight	25 lbs. (11.34 kg)	
9-Inch High Panel		
Number of Terminations	144	
Dimensions (HxWxD)	9.0 x 17.0 x 12.0 inches (22.9 x 435 x 281.7 mm)	See Figure 4
Weight	25 lbs. (11.34 kg)	
1.75-Inch High Panel		
Number of Terminations	12 or 24	
Dimensions (HxWxD)	1.73 x 17.0 x 12.0 inches (4.4 x 43.1 x 30.5 cm)	See Figure 5
Weight	10 lbs. (4.53 kg)	
3.5-Inch High Panel		
Number of Terminations	48	
Dimensions (HxWxD)	5.22 x 17.0 x 12.0 inches (13.3 x 43.1 x 30.5 cm)	See Figure 6
Weight	15 lbs. (6.8 kg)	

4 UNPACKING THE PRODUCT

Unpack and inspect the LSX panel as follows:

1. Inspect the exterior of the shipping container for evidence of rough handling that may have damaged the contents of the container.
2. Unpack the panel and associated components and check for possible damage.
3. If damage is detected or if parts are missing, file a claim with the commercial carrier and then notify CommScope Customer Service. Save the damaged carton for inspection by the carrier.

► **Note:** For information on how to contact CommScope Customer Service, if needed, refer to [Section 8](#) in this manual.

4. Save the shipping container for use in case the equipment requires shipment at a future date.

5 INSTALLATION

The main steps in installing an LSX panel are:

- Mounting the panel on the frame,
- Breaking out the cable to be spliced within the panel,
- Installing the cable on the outside of the panel, and
- Routing the cable within the panel from the cable clamp to the splice deck.

For instructions, refer to the following subsections.

5.1 Installing the Combination Module

► **Note:** Because of its extra depth due to its rear splice area, the LSX panel should be installed on an LGX fiber distribution frame with a depth of at least 15 inches (38.1 cm).

Install the panel from the front side of the rack, using the following procedure. Refer to [Figure 7](#).

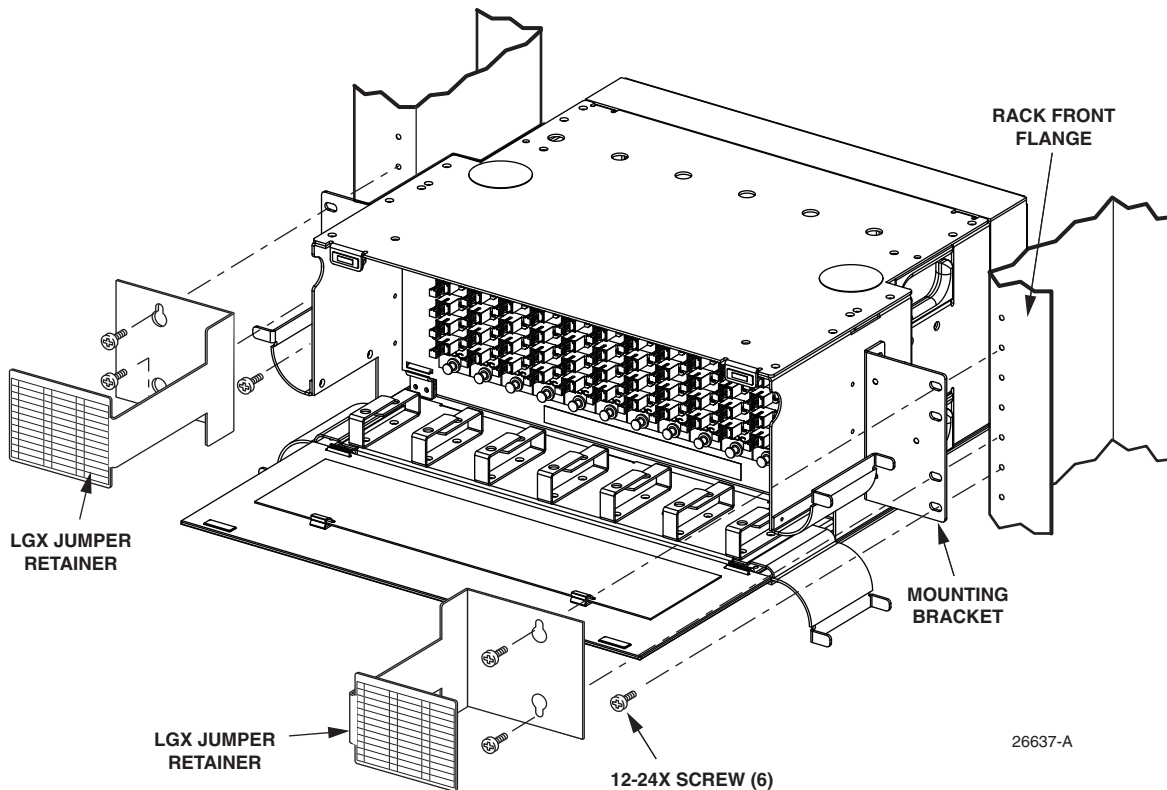

Figure 7. Installing the Connector Module (23-Inch Rack Shown)

1. Determine the mounting location and rack width, and reposition the mounting brackets if required:
 - a. If installing the panel on a 19-inch rack, remove the two mounting brackets and re-install them using the 19-inch orientation (refer to [Figure 4](#)).
 - b. If installing the panel on a 23-inch rack, install the chassis with the mounting brackets positioned as shipped.
2. Secure the mounting brackets to the rack front flange using six #12-24 mounting screws.

► **Note:** If jumper retainers are present on the rack, remove the jumper retainers and reinstall them with the chassis as shown in [Figure 7](#). The jumper retainers may be either LGX or the CommScope equivalent product.

5.2 Grounding an Armored Cable

When installing an armored cable, a procedure is required, before breaking out the cable, to sever and ground the armor. A CommScope kit is available for grounding the armor (catalog # GND-STPKIT). For details, refer to the instructions shipped with the kit (ADCP-90-382).

5.3 Breaking Out a Cable for Splicing

When preparing a cable for installation, break out and prepare the cable corresponding to [Figure 8](#) for stranded cable and [Figure 9](#) for ribbon cable.

- ▶ **Note:** [Figure 8](#) and [Figure 9](#) depict an IFC cable. For OSP cable, blocking and grounding kits (not shown) may be required, but breakout dimensions are otherwise the same. Kits are available from CommScope. For information on installing blocking and grounding kits, if required, refer to the instructions contained in the kits.
- ▶ **Note:** Kits for stranded cable breakouts are available from CommScope. Refer to catalog # 804, or contact CommScope Customer Assistance. For contact information, see [Section 8](#).

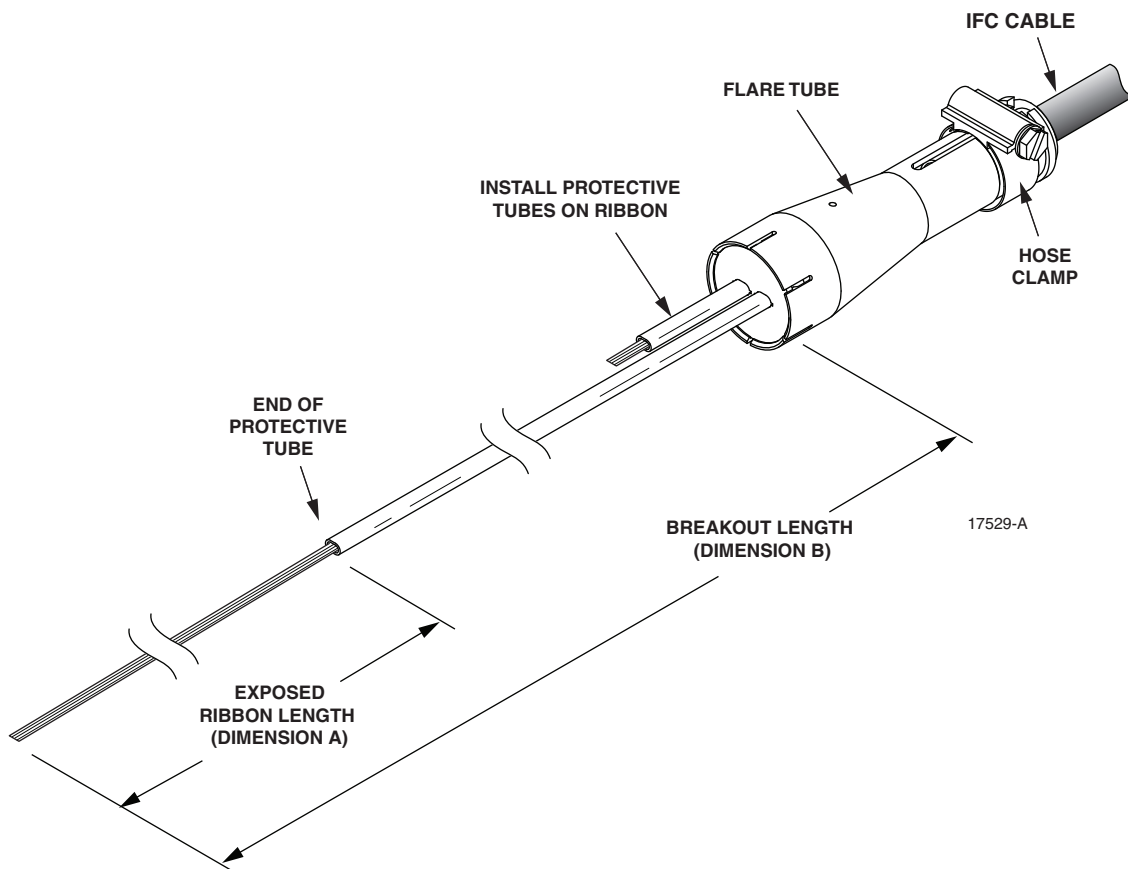

Chassis Height	Dimension A	Dimension B
1.75 in.	12.0 in. (+0.0/-1.0 in.) 30.5 cm (+0.0/-2.5 cm)	38.6 in. (+0.0/-6.0 in.) 96.5 cm (+0.0/-15.0 cm)
3.5 in.	12.0 in. (+0.0/-1.0 in.) 30.5 cm (+0.0/-2.5 cm)	45.5 in. (+0.0/-6.0 in.) 113.75 cm (+0.0/-15.0 cm)
7 in., 9 in.	31.0 in. (+0.0/-1.0 in.) 78.7 cm (+0.0/-2.5 cm)	137.0 in. (+0.0/-6.0 in.) 1372.5 cm (+0.0/-15.2 cm)

Figure 8. Recommended Breakout Dimensions for Ribbon Cable

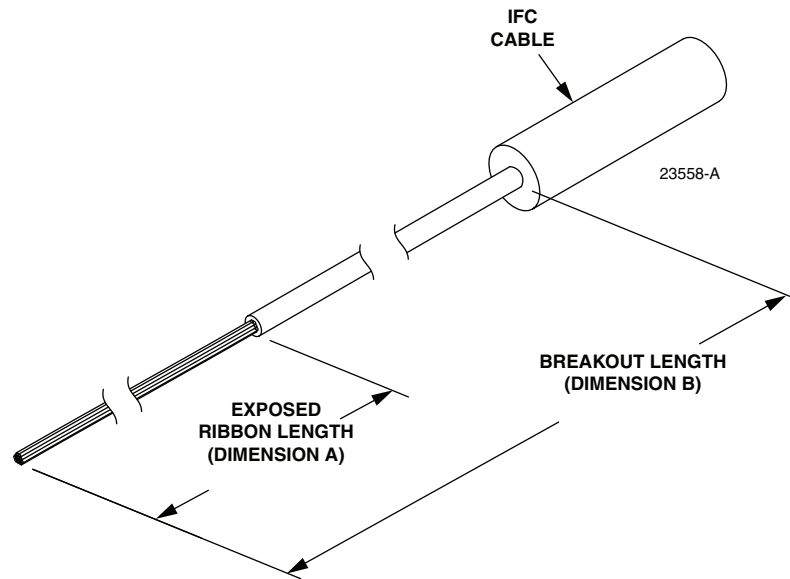

Chassis Height	Dimension A	Dimension B
1.75 in.	12.0 in. (+0.0/-1.0 in.) 30.5 cm (+0.0/-2.5 cm)	38.6 in. (+0.0/-6.0 in.) 96.5 cm (+0.0/-15.0 cm)
3.5 in.	12.0 in. (+0.0/-1.0 in.) 30.5 cm (+0.0/-2.5 cm)	45.5 in. (+0.0/-6.0 in.) 113.75 cm (+0.0/-15.0 cm)
7 in., 9 in.	12.0 in. (+0.0/-1.0 in.) 30.5 cm (+0.0/-2.5 cm)	94.0 in. (+0.0/-1.0 in.) 238.8 cm (+0.0/-2.5 cm)

Figure 9. Recommended Breakout Dimensions for Stranded Cable

5.4 Installing a Cable Clamp

Every LSX panel is shipped with a cable clamp that can be used to secure a cable to the chassis. This section contains instructions for the 7-inch and 9-inch high panels. For other panel heights, refer to the instructions provided in the cable clamp kit.

To install the cable clamp, use the following procedure. Refer to [Figure 10](#) for the 7-inch panel and [Figure 11](#) for the 9-inch panel.

► **Note:** The figures show the cable clamp bracket positioned for cable routing from above the panel. For cable routing from below the panel, turn the cable clamp bracket upside down compared to how it is shown in the figure and use the mounting holes designated in the figure as “for under floor cable entry.”

1. Install the cable clamp bracket on the clamp mount plate using two #12-24 screws. Be sure to position the cable clamp bracket corresponding to the note above.
2. Place the two standoffs in the standoff mounting holes in the cable clamp bracket.

► **Note:** There are four standoff mounting holes. Either the two left holes or two right holes can be used together, not the two in the middle. Do not mount two cables side by side.

- Two rubber yokes and either three or four grommets (depending on the kit) are provided with the cable clamp kit for securing the cable to the panel. Select the grommet that, when fitted on the cable, as shown in [Figure 12](#), provides the gap width shown.

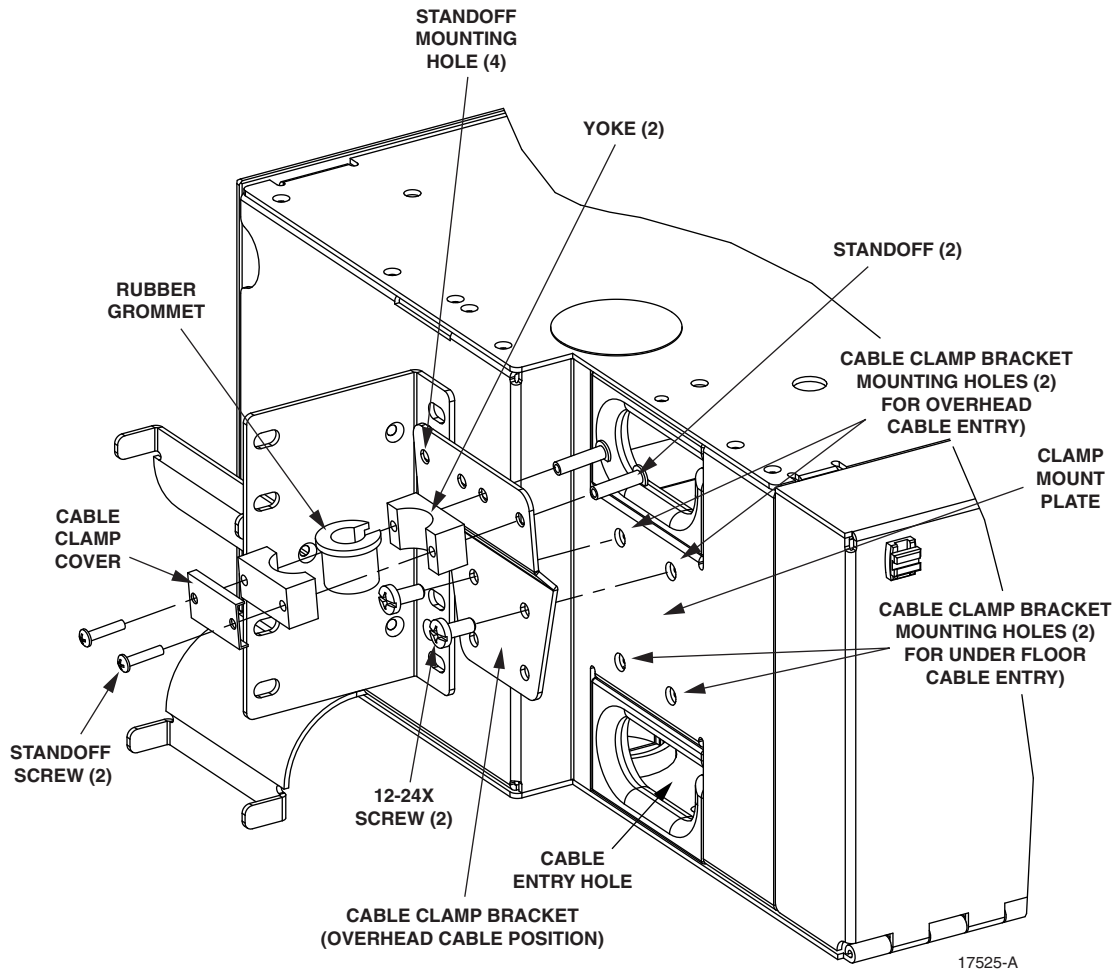

Figure 10. Installing a Cable Clamp (7-Inch Module)

- Open the splice area access door on the rear of the panel and direct the broken out section of the cable through the cable entry hole into the rear storage area of the panel. Allow the cable to remain in that position for later routing within the rear storage area.
- Working on the outside of the panel, where the cable bracket was installed, stack the cable clamp components on the standoffs, as shown in [Figure 10](#) and [Figure 11](#), with the cable secured within the rubber grommet. Position the cable so that the breakout point shown in [Figure 8](#) and [Figure 9](#) occurs just beyond the rubber grommet.
- Secure the cable clamp components to the standoffs using standoff screws, as shown in [Figure 10](#) and [Figure 11](#).
- If desired, install a cable shield using any of the three shields shipped with the panel. The purpose of the shield is to protect the cable where it enters the panel. [Figure 13](#) shows the

shield used for overhead cable. The package also contains an alternate shield used for under-floor cable and a box-shaped shield used with either overhead or under-floor cable.

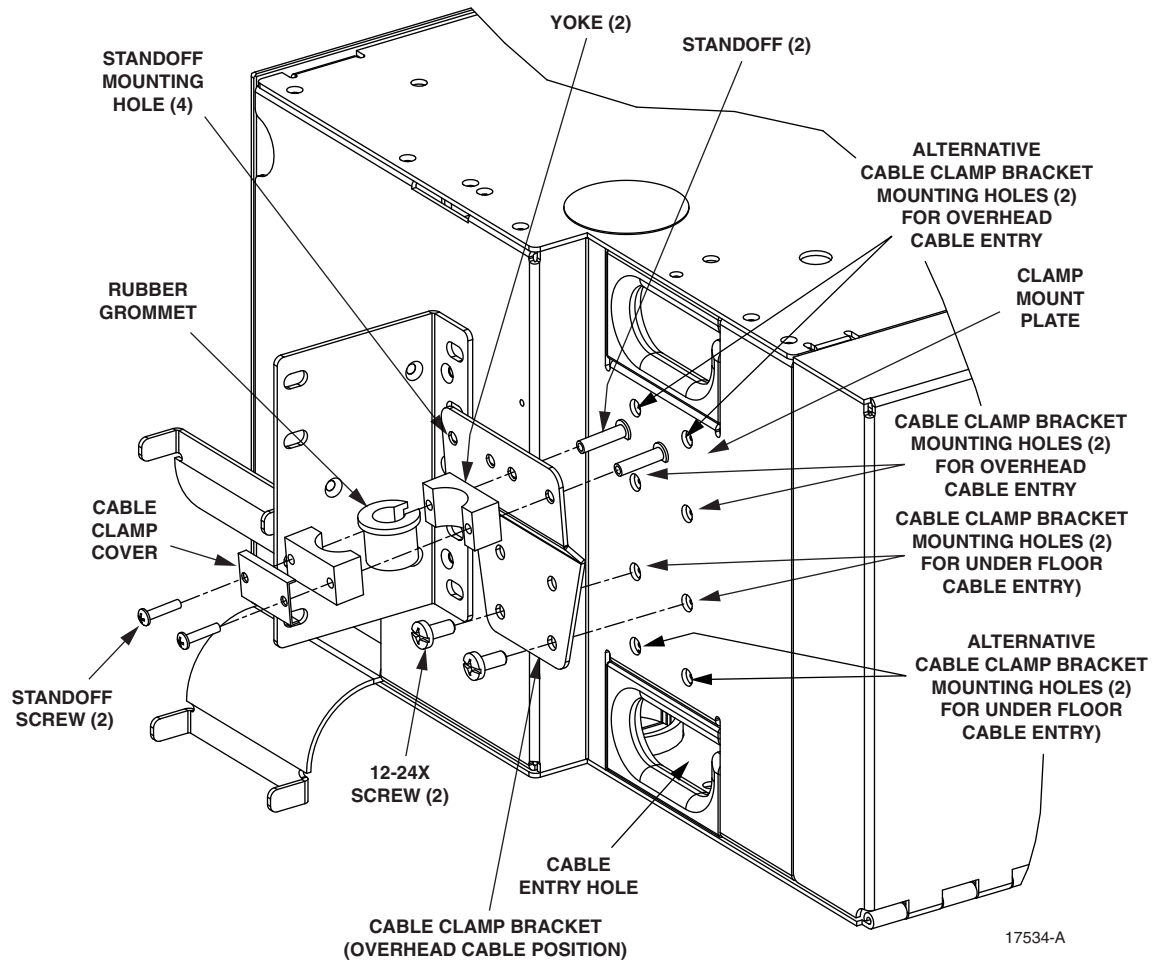

Figure 11. Installing a Cable Clamp (9-Inch Module)

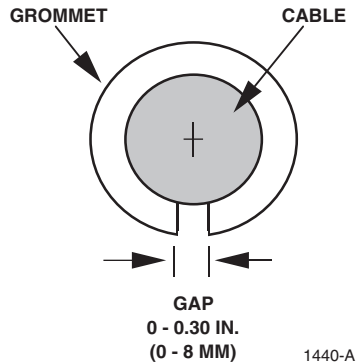
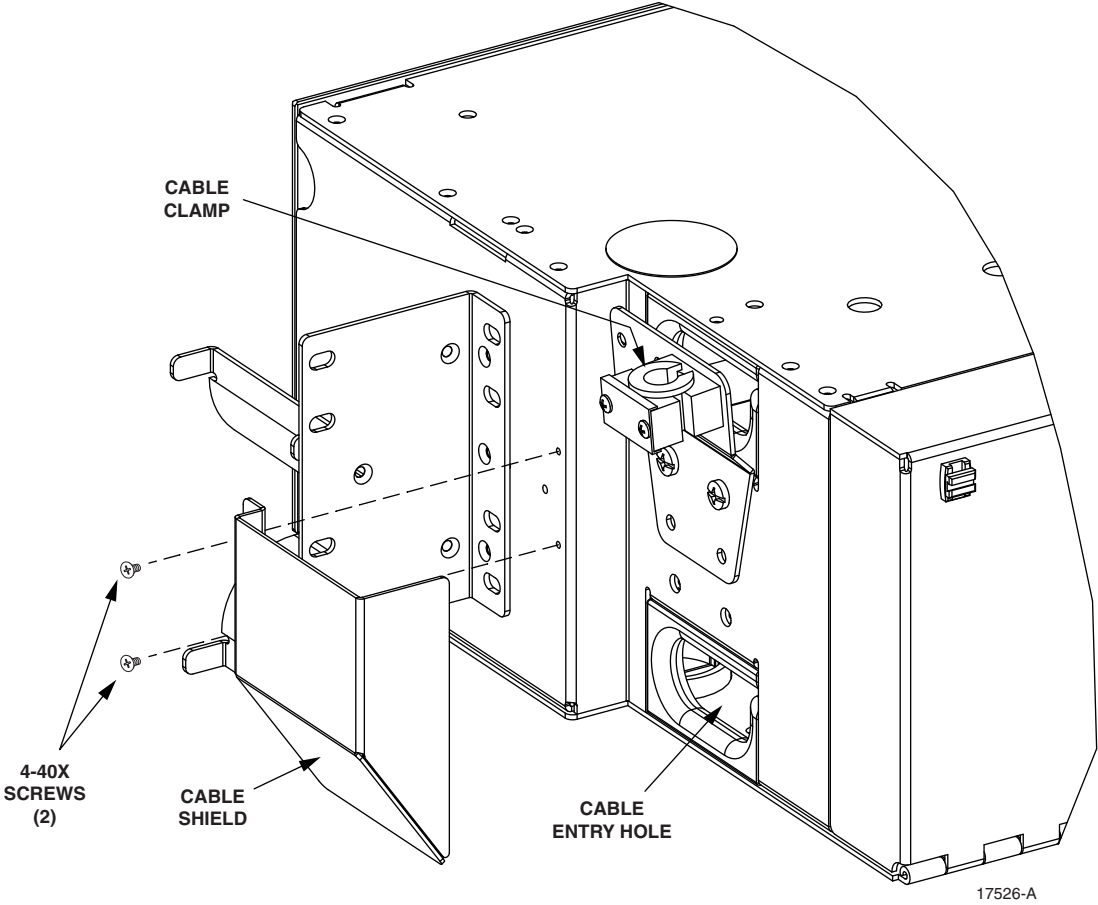

Figure 12. Grommet Selection



**Figure 13. Cable Shield Components
(Shield Shown is Used With Overhead Cable)**

5.5 Feeder Cable Routing

Separate procedures are provided in this section for different panel heights. For 7-inch and 9-inch high panels, refer to [Section 5.5.1 on Page 16](#). For 1.75-inch and 3.5-inch high panels, refer to [Section 5.5.2 on Page 17](#).

5.5.1 Cable Routing for 7-Inch and 9-Inch High Panels

Use the following procedure to route the feeder cable within the rear storage area and on the rear door splice deck. Refer to [Figure 14](#).

1. Route the cable from the entry hole horizontally across the rear storage area and form a single vertical loop by looping the cable twice through the rear set of curleyloks (following the same route as the internal pigtails in the front set of curleyloks).
2. Route the cable to the splice area access door.
3. Tie down the cable at the point where the exposed fibers emerge from the breakout per the breakout dimensions provided in [subsection 5.3](#).

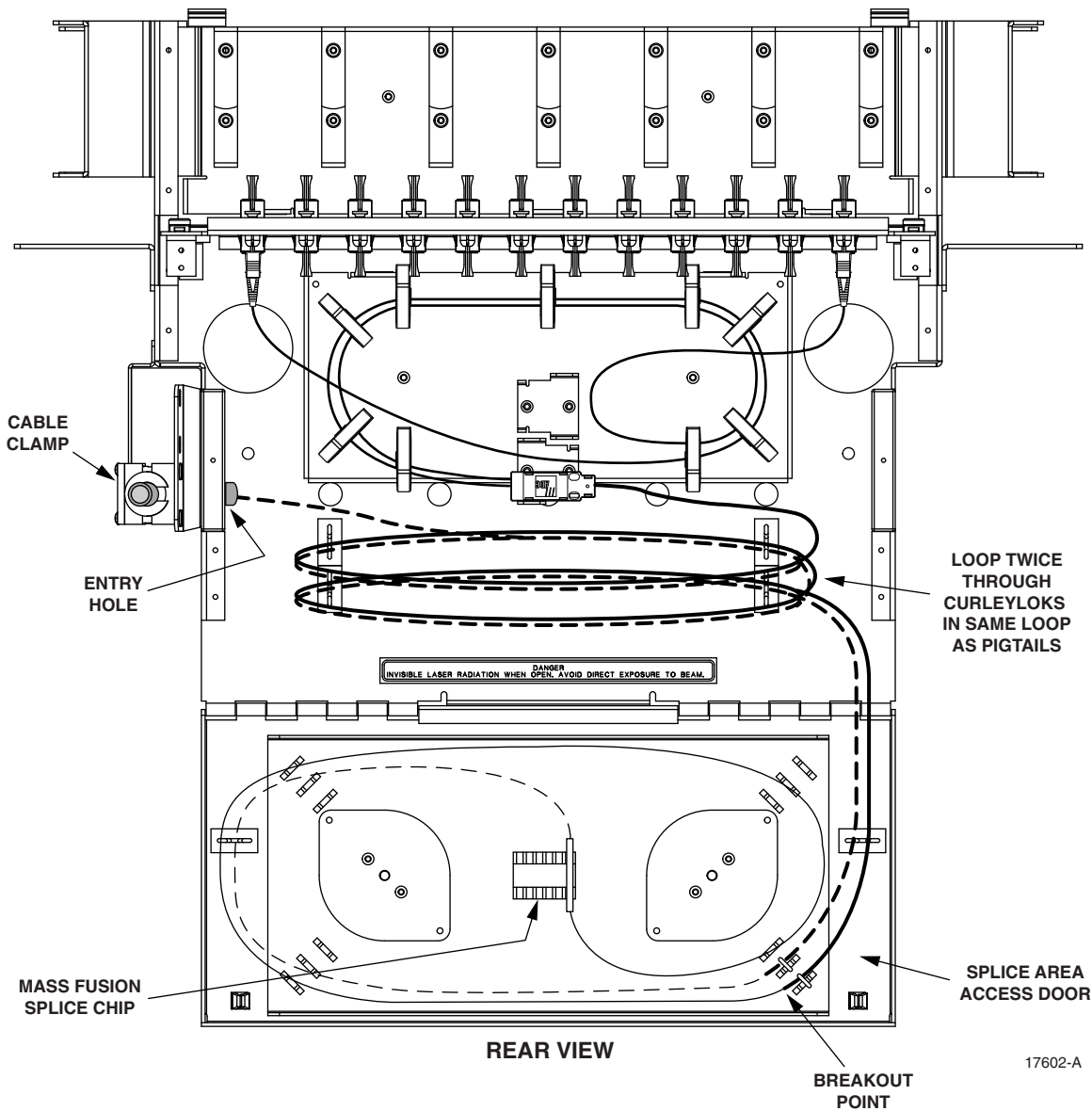

Figure 14. Cable Routing (7- and 9-Inch High Panel)

5.5.2 Cable Routing for 1.75 Inch High Panels

To route a cable into a 1.75 high panel, use the following procedure. [Figure 15](#) shows routing with the panel drawer extended.

1. Route the cable from the entry hole horizontally across the rear storage area and into the extended drawer.
2. Loop the cable around twice on the drawer and tie it down with lacing in the locations shown.
3. Route the cable to the splice tray as shown.
4. Tie down the cable at the point where the exposed fibers emerge from the breakout per the breakout dimensions provided in [subsection 5.3](#).

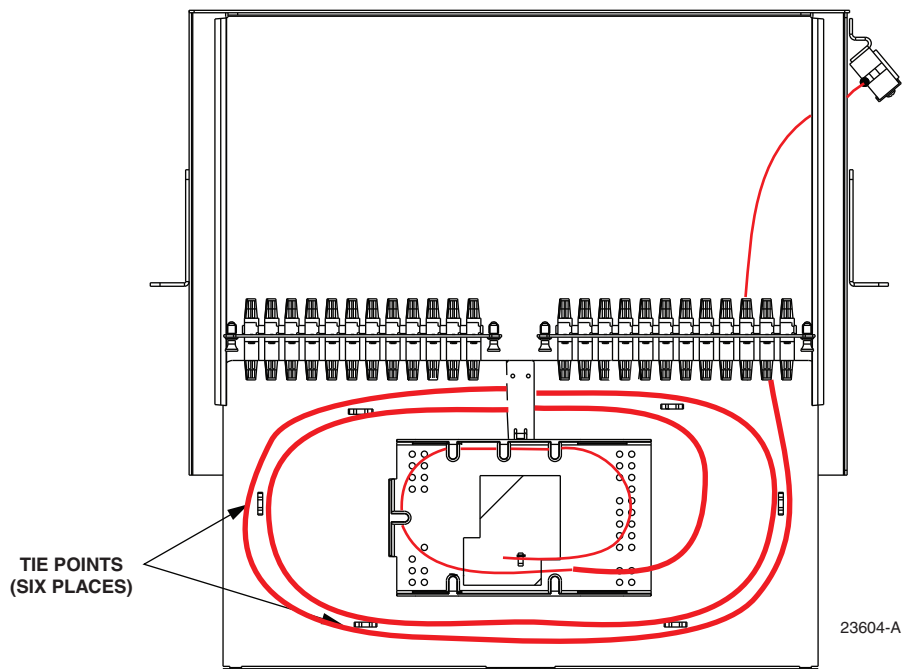

Figure 15. Cable Routing (1.75 Inch High Panel)

5.5.3 Cable Routing for 3.5 Inch High Panels

To route a cable into a 3.5 high panel, use the following procedure. [Figure 16](#) shows routing with the panel drawer extended.

1. Route the cable from the entry hole horizontally across the rear storage area and into the extended drawer.
2. Loop the cable around twice on the drawer and tie it down with lacing in the locations shown.
3. Route the cable to the splice tray as shown.
4. Tie down the cable at the point where the exposed fibers emerge from the breakout per the breakout dimensions provided in [subsection 5.3](#).

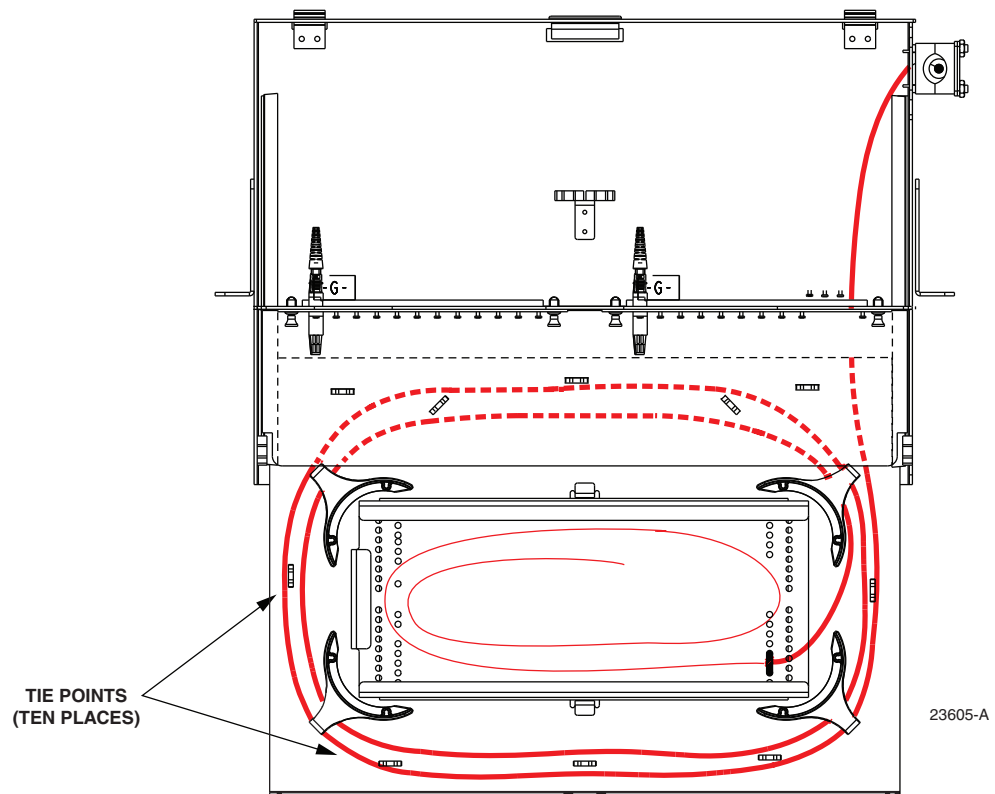

Figure 16. Cable Routing (3.5 Inch High Panel)

6 PATCH CORD ROUTING

Cross-connect patch cords on the LSX panels and LGX frame must be carefully routed to ensure they are properly protected. For details, refer to the following subsections.



Danger: *Infrared radiation is invisible and can seriously damage the retina of the eye. Do not look into the ends of any optical fiber. Do not look directly into the optical adapters of the adapter packs. Exposure to invisible laser radiation may result. An optical power meter should be used to verify active fibers. A protective cap or hood MUST be immediately placed over any radiating adapter or optical fiber connector to avoid the potential of dangerous amounts of radiation exposure. This practice also prevents dirt particles from entering the adapter or connector.*

6.1 Patch Cord Routing Within the LSX Module

Route patch cords vertically down the front of the adapter pack on each panel then left or right through the guides and radius limiters on the LSX panel (see [Figure 17](#)).

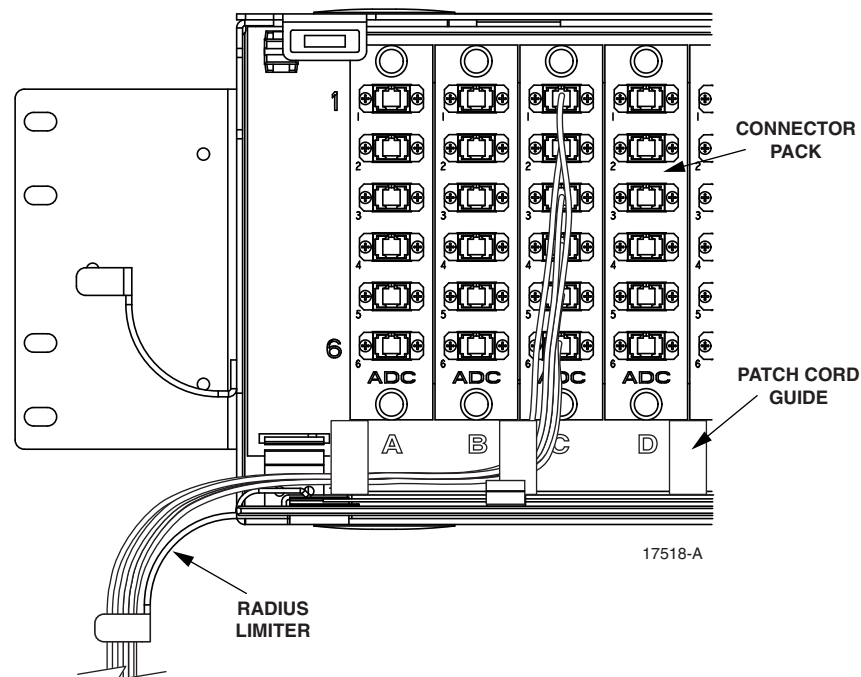

Figure 17. LSX Module Patch Cord Guides and Radius Limiters

6.2 Routing Patch Cords on the LGX Bay

When routing patch cords on the LGX bay, allow for a minimum of 6 in. (152 mm) of slack loop in the vertical trough. This loop aids in the tracing of patch cords and also facilitates removing a patch cord from the bundle. Additional fiber slack should be expected when installing a set of pre-connectorized patch cords. Refer to the following topics for patch cord details for a stand-alone bay, adjacent bays, and non-adjacent bays.

6.2.1 Cross-Connecting Within a Stand-Alone Bay

Cross-connecting within a stand-alone bay (shown in [Figure 18](#)) may be required when facility and equipment terminations are intermixed.

Most cross-connection routing within a stand-alone bay should be done with 5 meter (16.5 ft.) patch cords. Shorter 3 meter (9.9 ft.) patch cords can be used when both ends are terminated in the top half of the bay.

Use the following procedure to route patch cords on a stand-alone bay.

1. Loop the patch cord across the upper raceway.
 2. Route the right side of the patch cord down through the right vertical trough to the LSX panel where the right side of the patch cord will be terminated.
 3. Route the left side of the patch cord down through the left vertical trough to the LSX panel where the left side of the patch cord will be terminated.
 4. Route the ends of the patch cords inward from the vertical troughs to the respective points of termination. Connect the two ends of the patch cord at the desired adapters.
- **Note:** On same side terminations, one end of the patch cord will extend across the midline of the bay, as shown in [Figure 18](#) for patch cords 2 and 3. On opposite side terminations, the patch cord will not extend across the midline of the bay.
5. Adjust the slack length at both ends of the patch cord to about equal length and dress the excess length within the jumper retainers.

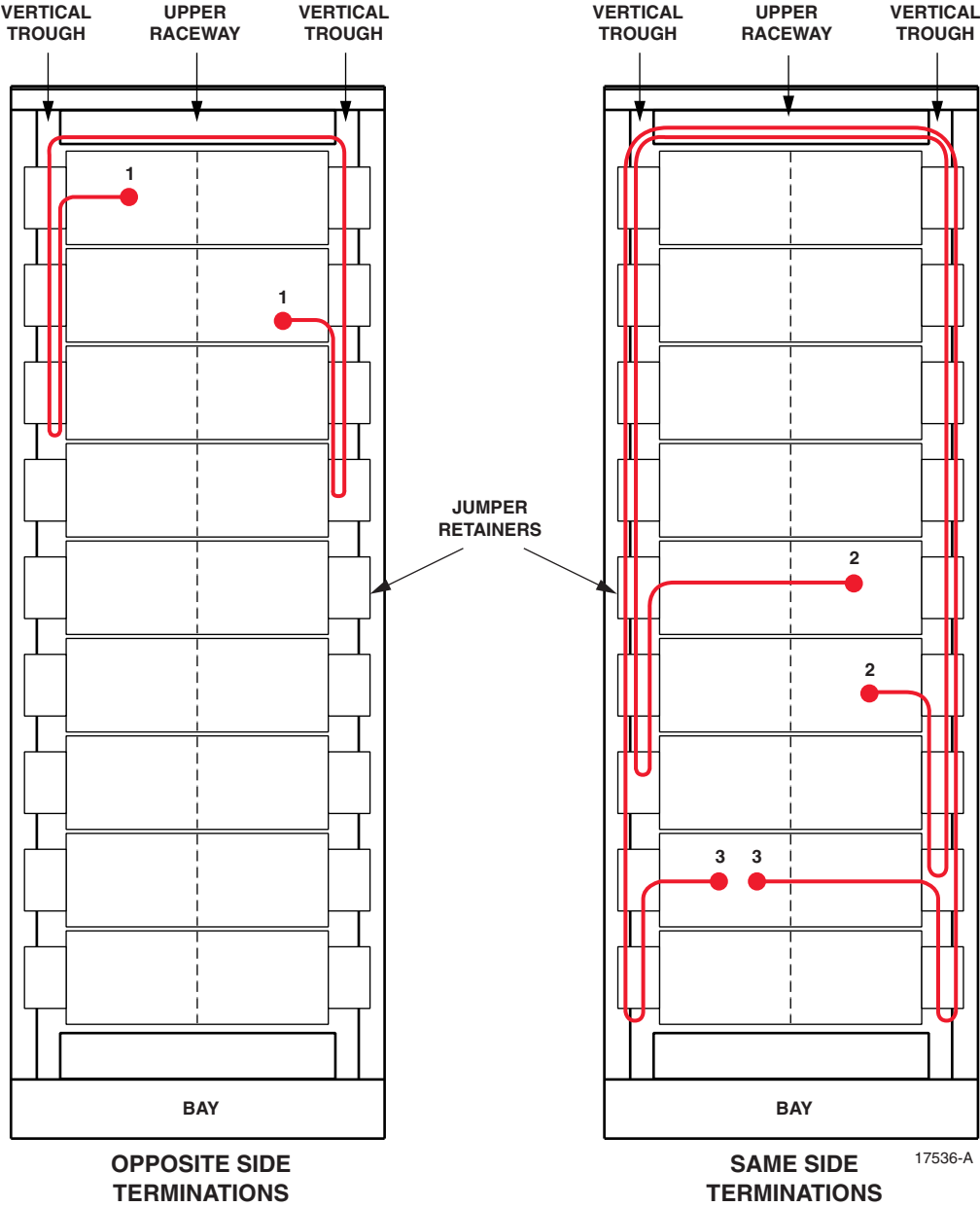
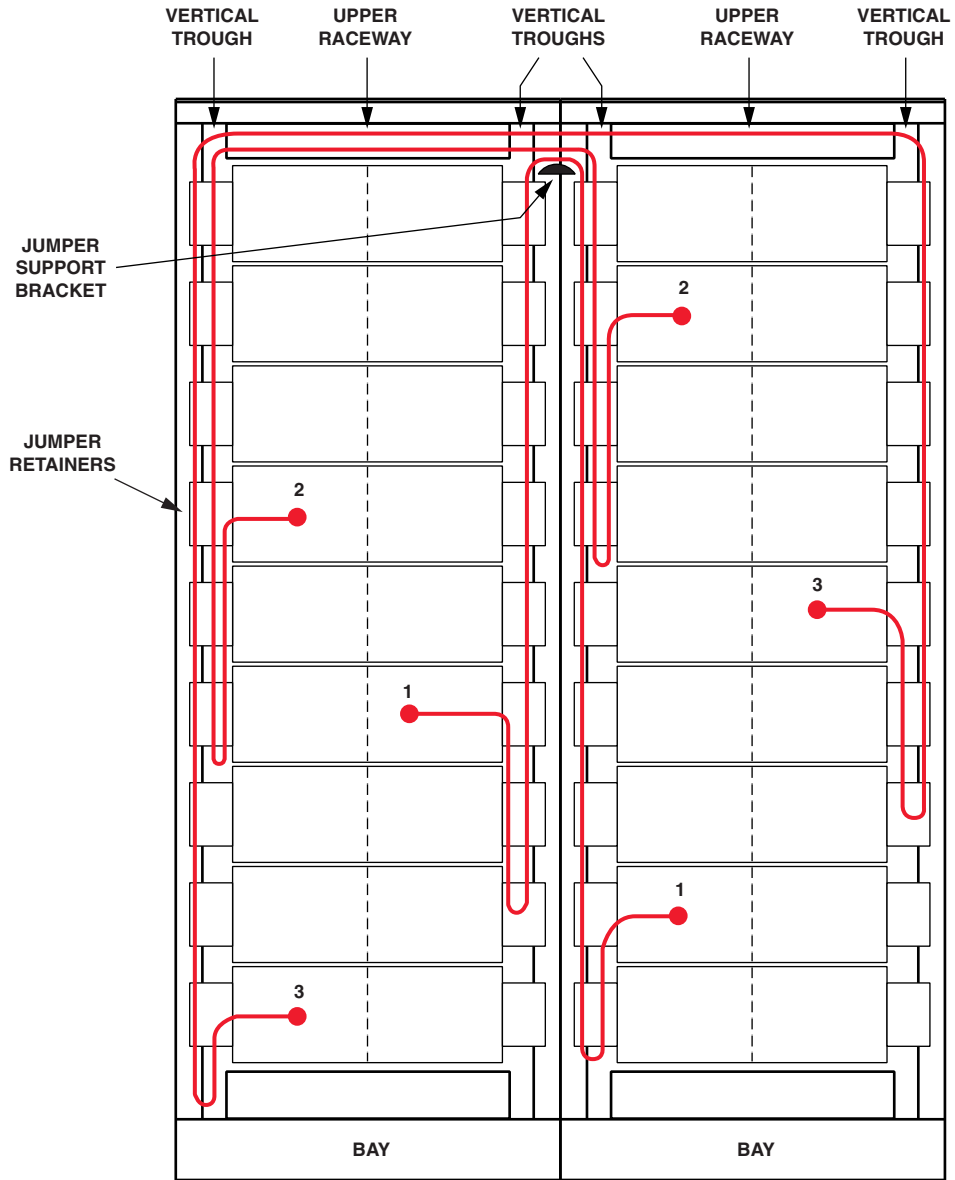

Figure 18. Routing Patch Cords on a Stand-Alone Bay

6.2.2 Cross-Connecting Between Adjacent Bays

Most cross-connection routing between adjacent racks should be done with 6 meter (19.8 ft.) patch cords. Shorter 4 meter (13.2 ft.) patch cords can be used when both ends are terminated in the top left of the frame. To route patch cords between adjacent bays (shown in Figure 19), use the following procedure.



17537-A

Figure 19. Routing Patch Cords Between Adjacent Bays

1. Terminate one end of the patch cord on the originating LSX panel and bay, then route the patch cord left or right to the nearest vertical trough.

2. At the destination panel and bay, terminate the opposite end of the patch cord, then route the patch cord left or right to the nearest vertical trough.
3. Loop the patch cord over the upper raceway or jumper support bracket to the adjacent rack.
4. Adjust the slack length at both ends of the patch cord to about equal length and dress the excess length within the jumper retainers.

6.2.3 Cross-Connecting to Non-Adjacent Bays

Patch cords may be routed through upper or lower raceways to non-adjacent bays in an LGX or LSX lineup. As a general rule, patch cords originating in LSX panels located in the upper half of an originating bay are routed to the upper raceway. Conversely, patch cords originating in panels located in the lower half of an originating bay are routed to the lower raceway.

6.2.3.1 Patch Cord Length Selection

Patch cord length is a concern when cross-connecting to non-adjacent bays because the bays may be at various distances from one another. To select the correct patch cord length, you must take into account the number of bays to be traversed and which raceways will be used to route the patch cord. To select a patch cord based on these factors, refer to [Table 2](#).

Table 2. Patch Cord Selection Table

BOTTOM HALF ORIGIN/BOTTOM HALF DESTINATION (LOWER TO LOWER RACEWAY)									
NUMBER OF BAYS	3, 4	5, 6	7, 8, 9	10, 11, 12	13	14, 15, 16	17, 18	19, 20, 21	N/A
JUMPER LENGTH	7.6 m (25 ft.)	9.2 m (30 ft.)	10.7 m (35 ft.)	12.2 m (40 ft.)	13.6 m (45 ft.)	15.2 m (50 ft.)	16.6 m (55 ft.)	18.1 m (60 ft.)	N/A
BOTTOM HALF ORIGIN/TOP HALF DESTINATION (LOWER TO UPPER RACEWAY)									
NUMBER OF BAYS	3	4, 5	6, 7	8, 9, 10	11, 12	13, 14	15, 16, 17	18, 19, 20	21
JUMPER LENGTH	6.1 m (20 ft.)	7.6 m (25 ft.)	9.2 m (30 ft.)	10.7 m (35 ft.)	12.2 m (40 ft.)	13.6 m (45 ft.)	15.2 m (50 ft.)	16.6 m (55 ft.)	18.1 m (60 ft.)
TOP HALF ORIGIN/TOP HALF DESTINATION (UPPER TO UPPER RACEWAY)									
NUMBER OF BAYS	3	4, 5	6, 7, 8	9, 10	11, 12	13, 14	15, 16, 17	18, 19	20, 21
JUMPER LENGTH	4.9 m (16 ft.)	6.1 m (20 ft.)	7.6 m (25 ft.)	9.2 m (30 ft.)	10.7 m (35 ft.)	12.2 m (40 ft.)	13.6 mm (45 ft.)	15.2 m (50 ft.)	16.6 m (55 ft.)
TOP HALF ORIGIN/BOTTOM HALF DESTINATION (UPPER TO LOWER RACEWAY)									
NUMBER OF BAYS	3, 4	5, 6, 7	8, 9	10, 11	12, 13	14, 15, 16	17, 18	19, 20, 21	N/A
JUMPER LENGTH	6.1 m (20 ft.)	7.6 m (25 ft.)	9.2 m (30 ft.)	10.7 m (35 ft.)	12.2 m (40 ft.)	13.6 m (45 ft.)	15.2 m (50 ft.)	16.6 m (55 ft.)	N/A

N/A: Not applicable

6.2.4 Routing Patch Cords Starting in the Lower Raceway

To cross-connect starting in the lower raceway, use the following procedure. Refer to [Figure 20](#) and [Figure 21](#).

1. Terminate one end of each patch cord at the originating panel and bay, then route the patch cord left or right to the nearest vertical trough.
2. Route the end of the patch cord terminated in step 1 down the left or right vertical trough to the lower raceway.

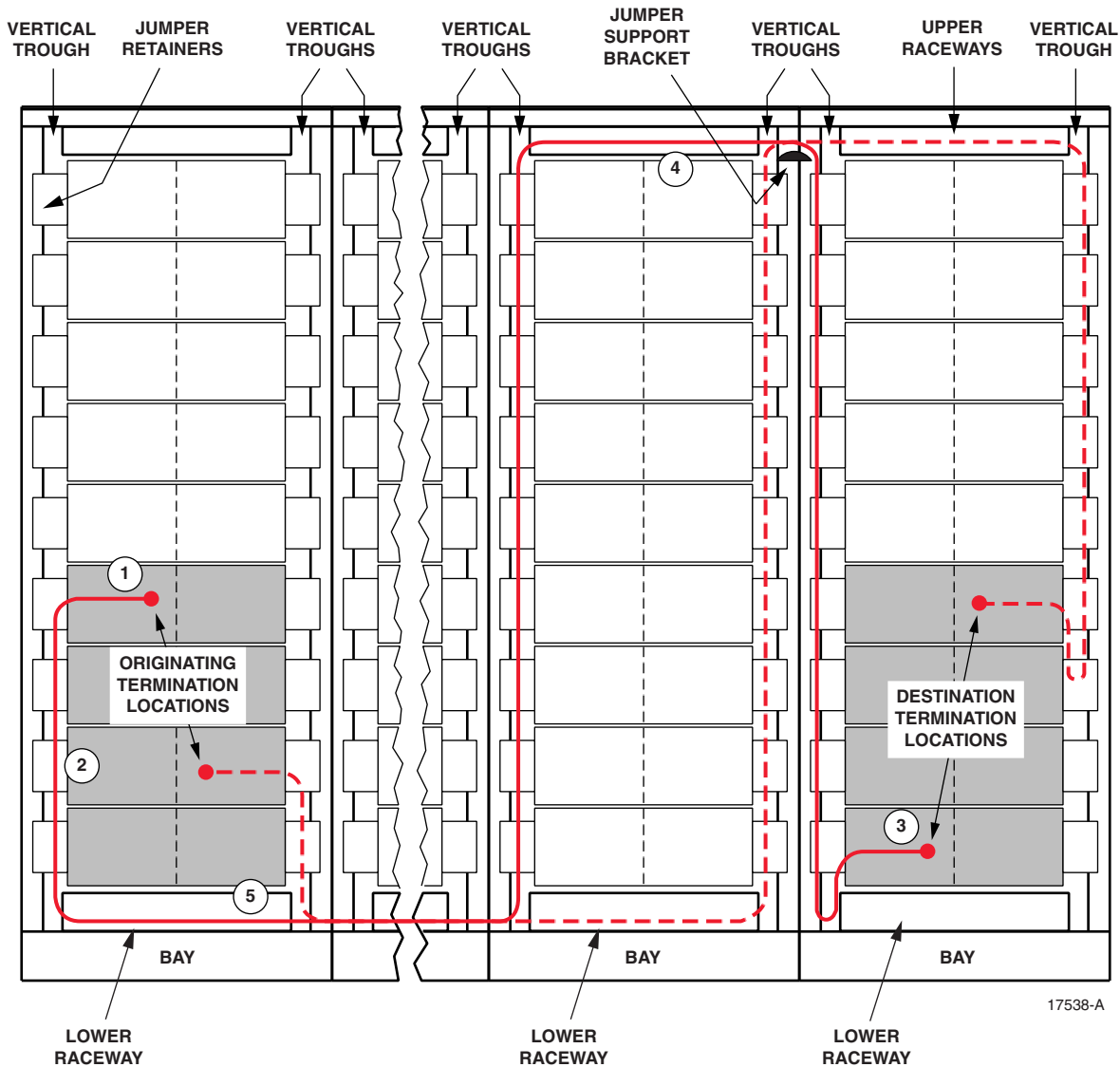
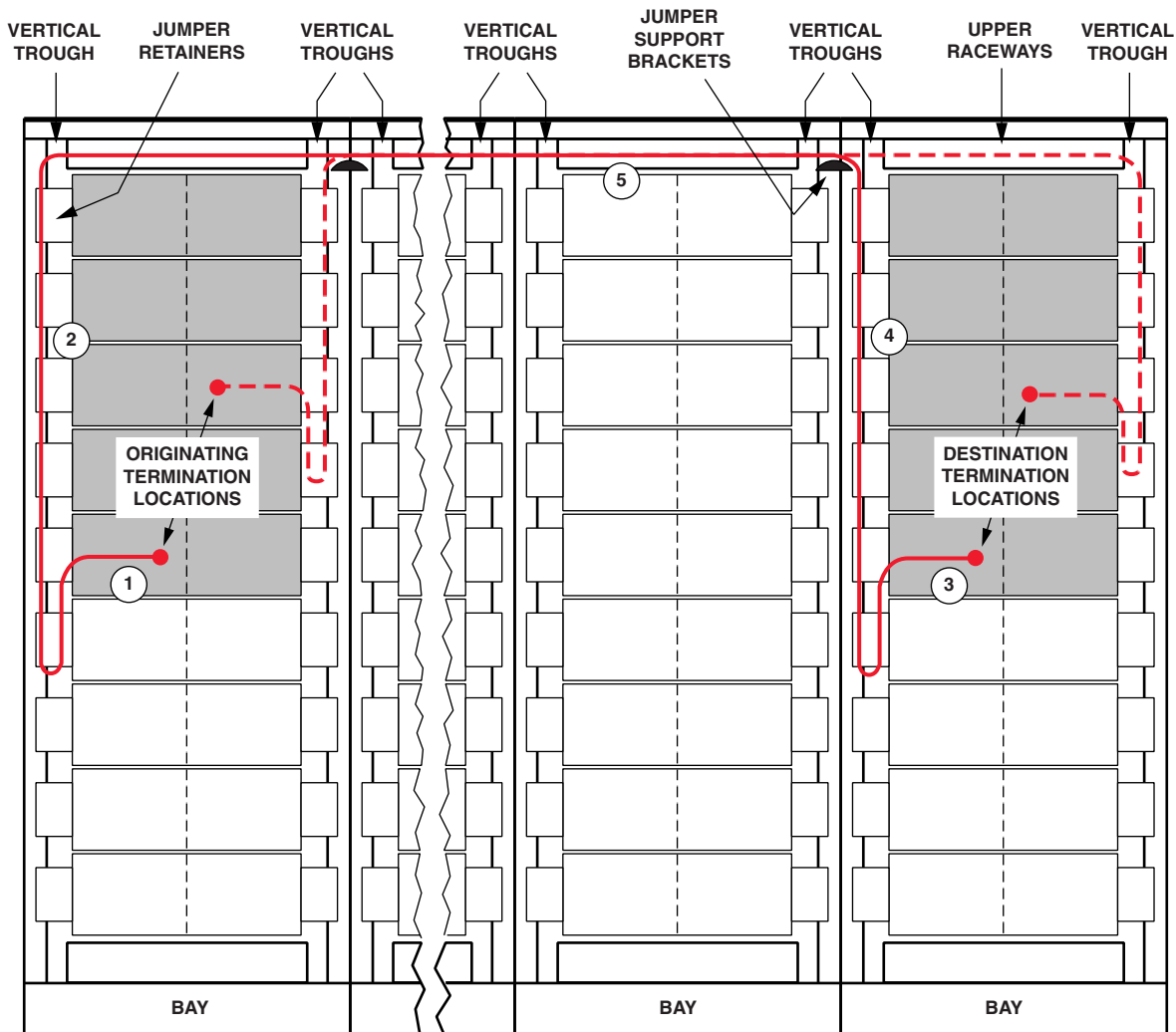

Figure 20. Routing Patch Cords Starting in the Lower Raceway (Bottom to Bottom)

3. At the destination panel and bay, terminate the opposite end of the patch cord, then route the patch cord left or right to the nearest vertical trough.
 4. Route the end of the patch cord terminated in step 3 up the left or right vertical trough and over the upper raceway across the top of one bay as shown in [Figure 20](#) and [Figure 21](#).
- **Note:** Use the lower trough as the main raceway since it tends to be less congested. Route the patch cord through the upper raceway for one bay length only.
5. Insert the patch cords in the lower raceway between the origin and destination bays. Adjust the slack loops in the vertical troughs to prevent buildup within the raceway.



17540-A

Figure 21. Routing Patch Cords Starting in the Lower Raceway (Bottom to Top)

6.2.5 Routing Patch Cords Starting in the Upper Raceway

To cross-connect starting in the upper raceway, use the following procedure. Refer to [Figure 22](#) and [Figure 23](#).

1. Terminate one end of each patch cord on the originating panel and bay and then route the patch cord left or right to the nearest vertical trough.
2. Route the end of the patch cord terminated in step 1 up the left or right vertical trough to the upper raceway.
3. At the destination panel and bay, terminate the opposite end of the patch cord and then route the patch cord left or right to the nearest vertical trough.
4. Route the patch cord terminated in step 3 up the left or right vertical trough as shown in [Figure 22](#) and [Figure 23](#).

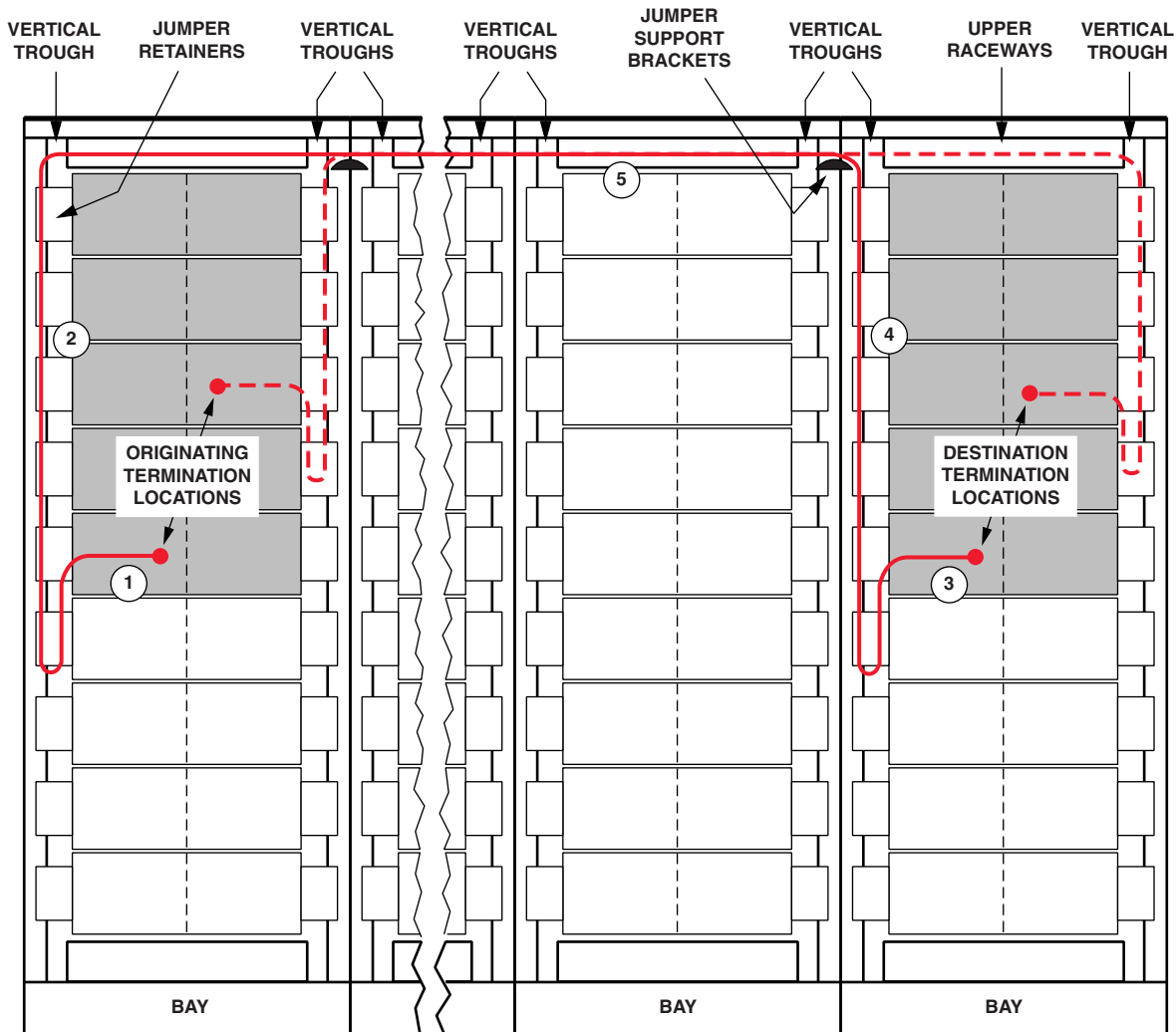

17540-A

Figure 22. Routing Patch Cords in the Upper Raceway (Top to Top)

- 5. Insert the patch cords in the upper raceway between the origin and destination bays. Adjust the slack loops in the vertical troughs to prevent buildup within the raceway.

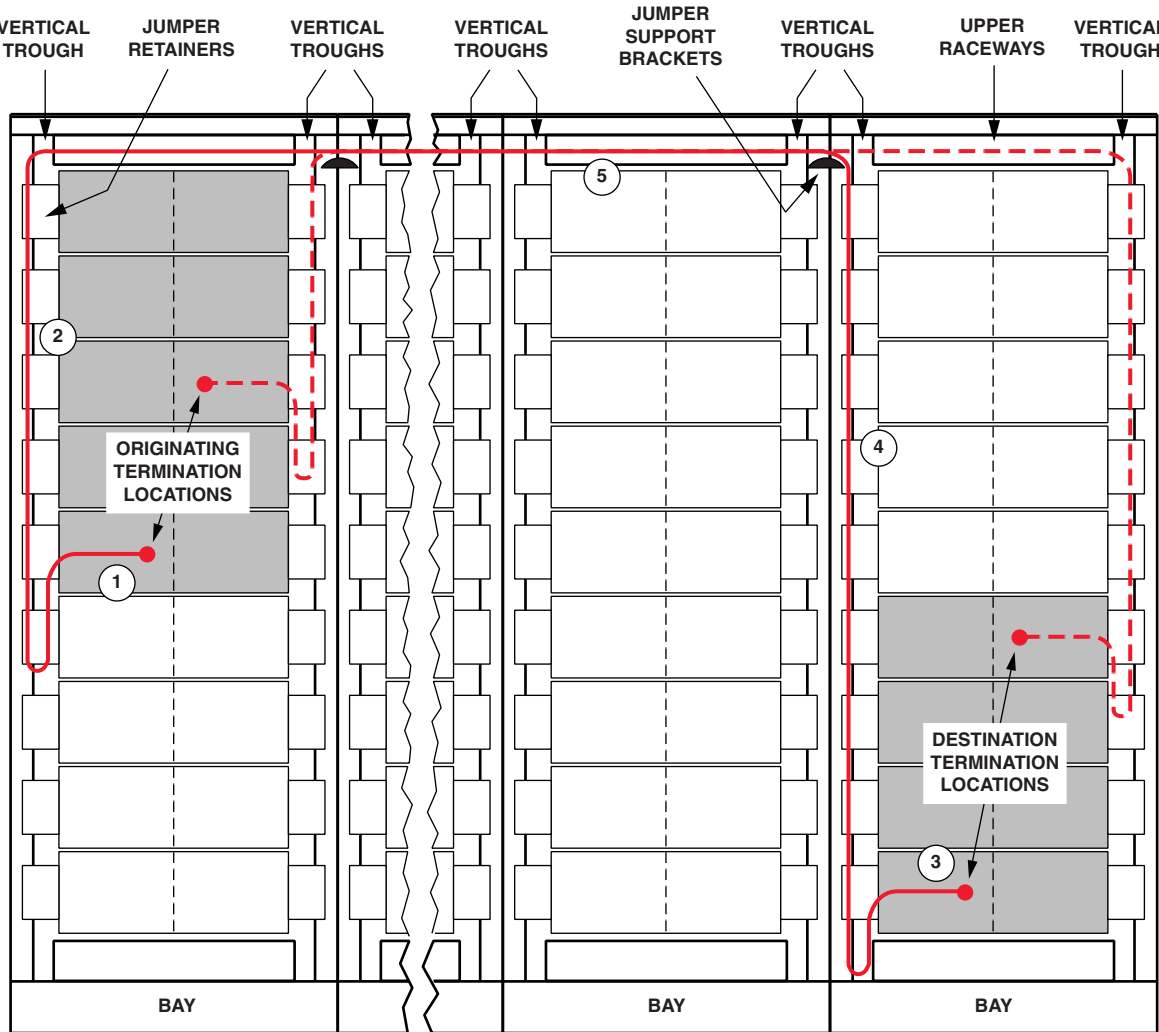

17541-A

Figure 23. Routing Patch Cords in the Upper Raceway (Top to Bottom)

6.3 Mounting 144-Position Modules Adjacent to 72 or 96 Position Modules

Frames with a depth of 15 inches (38.1 cm) are recommended to accommodate the 15 inch depth of the LSX termination/splice panel. The additional depth of the termination/splice panel is due to the additional room required for the splice deck on the rear of the panel. Termination only panels have a depth of 12 inches.

If a 15 inch deep frame is not available, use a rear duct extension kit to extend backward the rear doors of the frame. The new 15 inch deep frame will line up with any existing 12 inch deep (30.5 cm) frame as shown in [Figure 24](#).

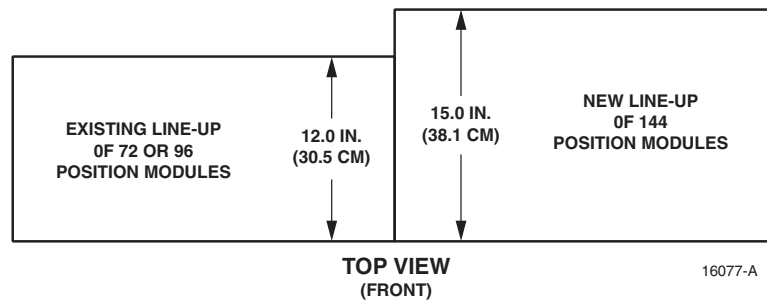

Figure 24. Front-to-Back Module Misalignment

7 OPERATION

7.1 Removing a Cover for Easier Access

The front cover of the chassis may be removed to provide easier access for cable routing. To remove a cover, lift it straight out of the hinges. To replace a cover, position the hinge edge of the cover on the hinges and press inward to push the edge into the hinges.

7.2 Patching and Testing



Danger: *Infrared radiation is invisible and can seriously damage the retina of the eye. Do not look into the ends of any optical fiber. Do not look directly into the optical adapters of the adapter packs. Exposure to invisible laser radiation may result. An optical power meter should be used to verify active fibers. A protective cap or hood MUST be immediately placed over any radiating adapter or optical fiber connector to avoid the potential of dangerous amounts of radiation exposure. This practice also prevents dirt particles from entering the adapter or connector.*

Testing and patching of optical circuits are done on the front of the LSX panel using patch cords. Whenever patch cords are installed, route them down and to the side, as with cross-connect patch cords. Refer to [Figure 25](#) below; see also [Figure 17](#) on page 19.

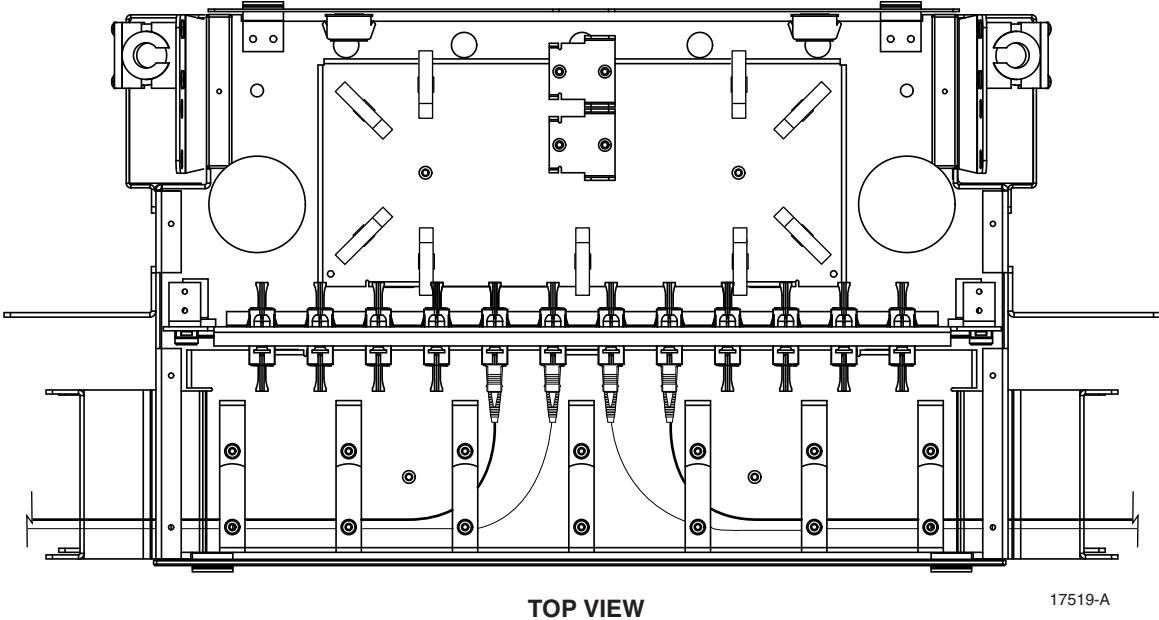

Figure 25. Correct Routing of Patch Cords

8 CUSTOMER INFORMATION AND ASSISTANCE

To find out more about CommScope® products, visit us on the web at
www.commscope.com

For technical assistance, customer service, or to report any missing/damaged parts, visit us at
<http://www.commscope.com/SupportCenter>

COMMSCOPE®