

ITEM	PART NO.	DESCRIPTION	QTY.	WEIGHT
1	CMSL.01	CHAIN MOUNT STIFF ARM ANGLE	1	20.10 LBS
2	CMSH30H	HARDWARE KIT (ITEMS 3 THRU 9)	1	
3	CM.01	CHAINMOUNT ANCOR	2	5.95 LBS
4	CM.03	CHAIN LOCK	2	0.27 LBS
5	CM.04	1/2" RIGHT HAND THREAD JAW	2	0.58 LBS
6	GB-0516A	5/8" X 1-3/4" GALV BOLT KIT (A325)	2	0.25 LBS
7	GWL-04	1/2" GALV LOCK WASHER	1	0.01LBS
8	GN-04	1/2" GALV HEX NUT (C2)	1	0.04 LBS
9	G4-0-96	G-40 CHAIN 8ft	2	6.00 LBS

REVISIONS				
REV.	ZONE	DESCRIPTION	BY	DATE
A		INITIAL RELEASE	AW	09/21/04
B		UPDATED BOM	AW	08/14/06

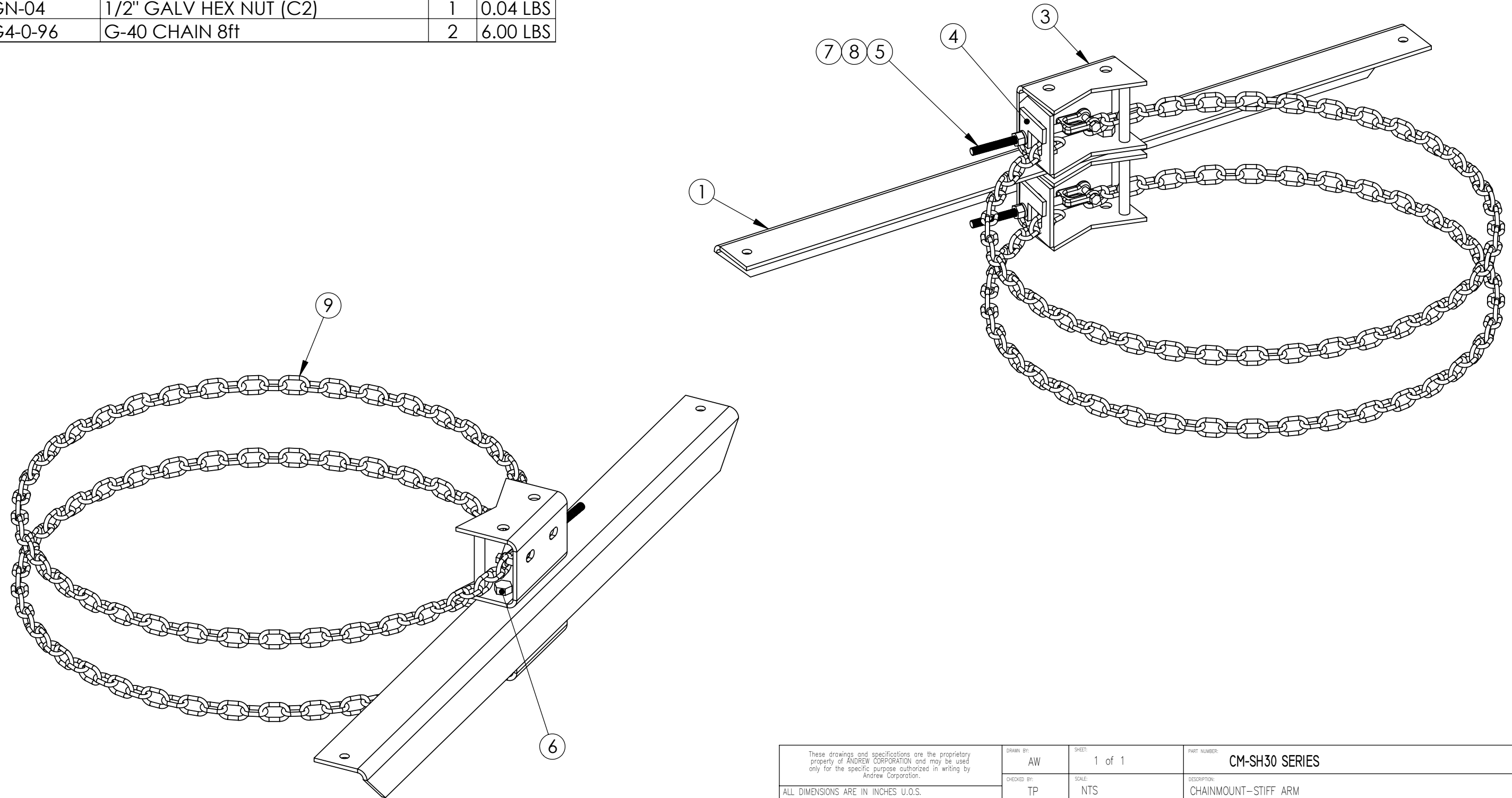

These drawings and specifications are the proprietary property of ANDREW CORPORATION and may be used only for the specific purpose authorized in writing by Andrew Corporation.  ALL DIMENSIONS ARE IN INCHES U.O.S. TOLERANCES UNLESS OTHERWISE SPECIFIED: .X = .06      ANGLES      2' .XX = .03      FRACTIONS      1/32 .XXX = .010  REMOVE BURRS AND BREAK EDGES .005  DO NOT SCALE THIS PRINT	DRAWN BY: AW	SHEET: 1 of 1	PART NUMBER: CM-SH30 SERIES
	CHECKED BY: TP	SCALE: NTS	DESCRIPTION: CHAINMOUNT-STIFF ARM
	DATE: 9/21/04	MATERIAL: A36	DRAWING TYPE: ASSEMBLY DRAWING
	REVISION: <b>B</b>	FINISH: GALV	WEIGHT: 50.00 LBS