

4

3

2

1

REVISIONS			
REV	DESCRIPTION	DATE	APPROVED
A	ECR 800003574: REL TO PRODUCTION PER EAO 601665	24JUL14 JJH	MB XA
C	ECR 8000010306: ADD DIMENSIONS.	20OCT15 RY	S.LIU/JIHE

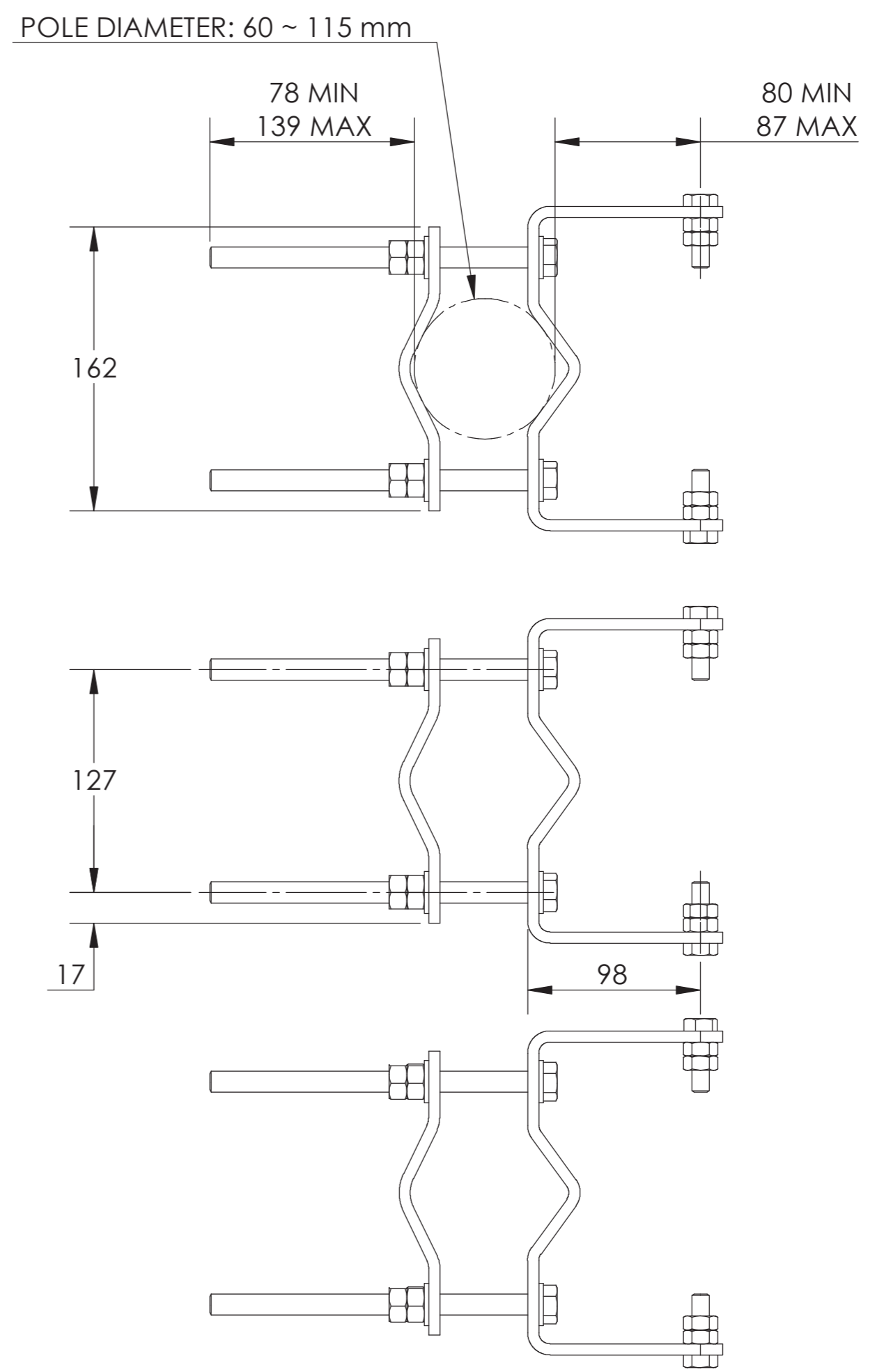
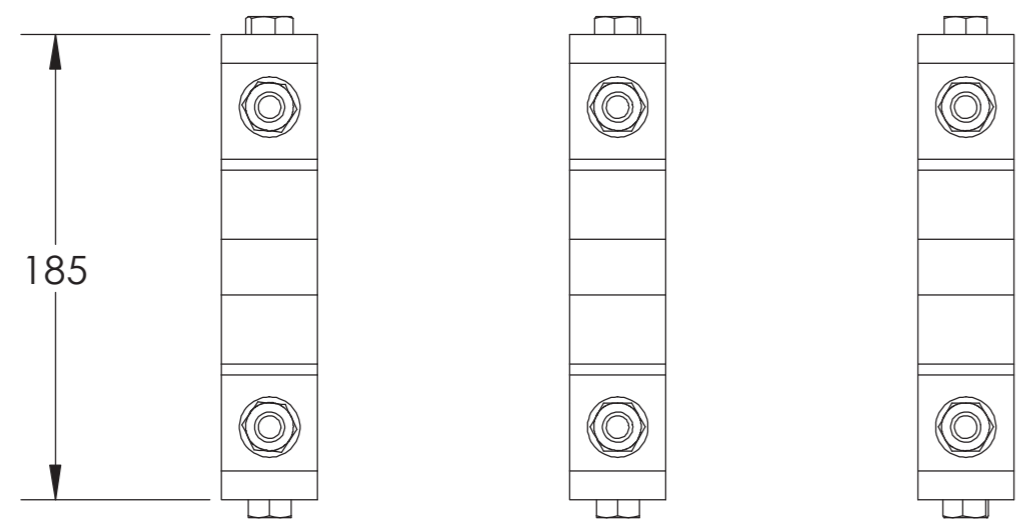
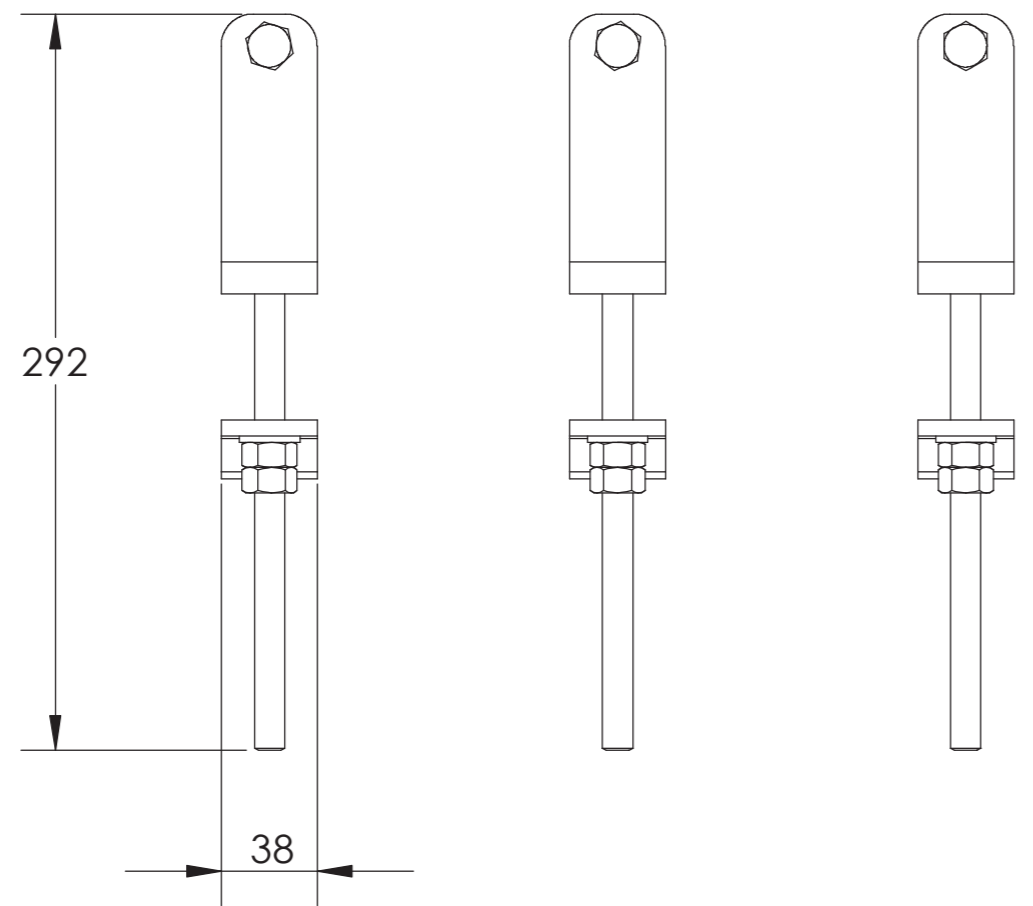

# DB380-OFFSET

MATERIAL N/A	DENSITY: N/A	UNLESS OTHERWISE SPECIFIED DIMENSIONS ARE IN MILLIMETERS INTERPRET PER ISO STANDARDS HANDBOOK TECHNICAL DRAWINGS VOLUMES 1 & 2, THIRD EDITION (2002)	WESTCHESTER, IL. 60154 U.S.A.					
	MASS: 13.80 kg		ANDREW®					
FINISH N/A	TOLERANCES		THIRD ANGLE PROJECTION					
	0 PLACE X ±							
	1 PLACE .X ±							
	2 PLACE .XX ±		DRAWN BY JJH 24JUL14					
ANGLES ±		ECN 8000010306-O		SIZE <b>A2 84147</b>				
ALL SURFACES ✓		AUTH. GROUP 23		DOCUMENT NO. DB380-OFFSET-L				
NOTICE: These drawings and specifications are the proprietary property of ANDREW CORPORATION and may be used only for the specific purpose authorized in writing by Andrew.		VERSION 00	STATUS RE	REVISION B	VERSION 03	STATUS RE	REVISION C	SHEET 1 OF 1

4

3

2

1