

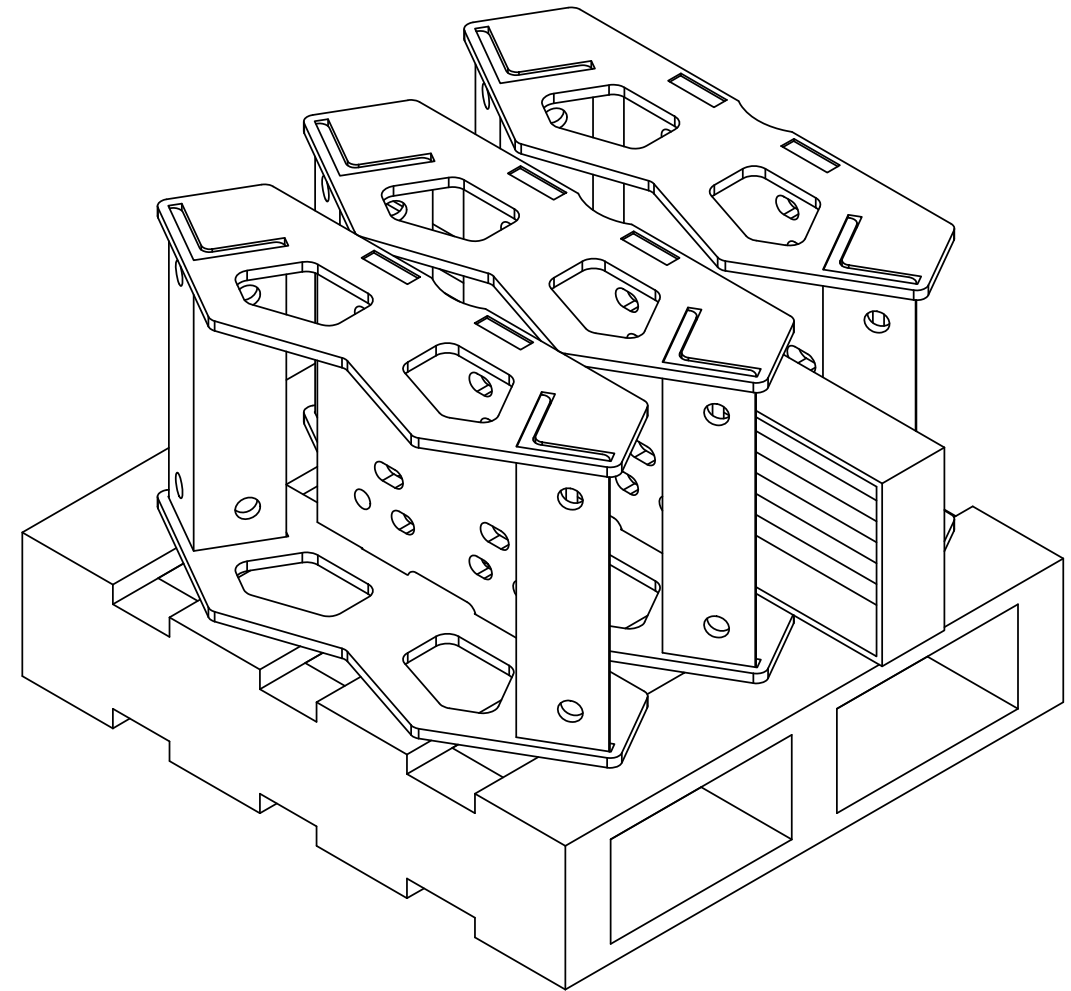

ITEM	PART NO.	DESCRIPTION	QTY.	WEIGHT	NOTE NO.
1	RMSPALLET	PALLET FOR SMALL RINGMOUNTS	1	13.56 LBS	
2	RM1030305	10-30 3-SECTOR RM WLDMNT	3	44.53 LBS	
3	RMS3H	10"-30" RINGMOUNT HARDWARE KIT	1	20.88 LBS	

REVISIONS				
REV.	ECN	DESCRIPTION	BY	DATE
F		INITIAL RELEASE	AW	08/30/04
G		UPDATE TOLERANCE BLOCK	MSM	02/22/08
H		UPDATE HARDWARE KIT / SHEET FORMAT	MSM	08/05/10
J		REDESIGNED RING MOUNTS	DRR	09/01/10
K		UPDATED COMPONENT ON ITEM #1	HC	1/8/2014
L	8000007159	NEW MOUNT WELDMENT	MSM	03/05/15



NOTES:

1. BAND TO PALLET AS NEEDED FOR SHIPPING.
2. CUSTOMER ASSEMBLY SHEET 2.

<small>These drawings and specifications are the proprietary property of ANDREW CORPORATION and may be used only for the specific purpose authorized in writing by Andrew Corporation.</small> ALL DIMENSIONS ARE IN INCHES U.O.S. TOLERANCES UNLESS OTHERWISE SPECIFIED: .X = ± .12 ANGLES ±2° .XX = ± .06 FRACTIONS ±1/32 .XXX = ± .03 REMOVE BURRS AND BREAK EDGES .005 DO NOT SCALE THIS PRINT	DRAWN BY: AW	SHEET: 1 of 2	PART NUMBER: MC-RM1030-3
	CHECKED BY: TP	SCALE: NTS	DESCRIPTION: 10-30 RING MOUNT
	DATE: 08/30/04	MATERIAL: A36, A529	DRAWING TYPE: ASSEMBLY DRAWING
	REVISION: L	FINISH: GALV, A123	
	WEIGHT: 153.58	WESTCHESTER, IL. 60154 U.S.A.	

ITEM	PART NO.	DESCRIPTION	QTY.	WEIGHT	NOTE NO.
1	RM1030305	10-30 3-SECTOR RM WLDMNT	3	44.53 LBS	
2	MT-384-24	3/4" X 24" GALV THREADED ROD	6	3.01 LBS	
3	GWL-06	3/4" GALV LOCK WASHER	12	0.04 LBS	
4	GN-06	3/4" GALV HEX NUT	12	0.12 LBS	

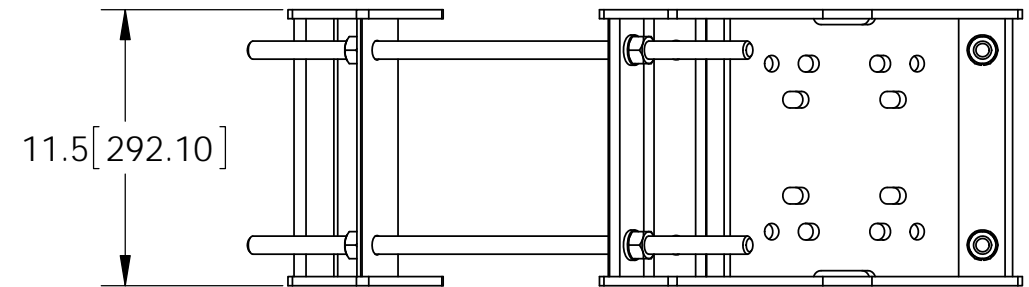
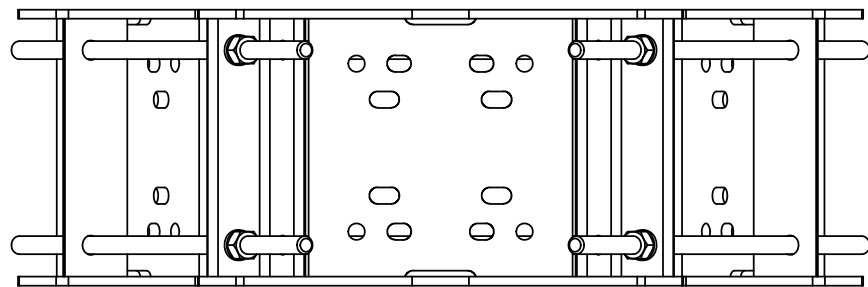
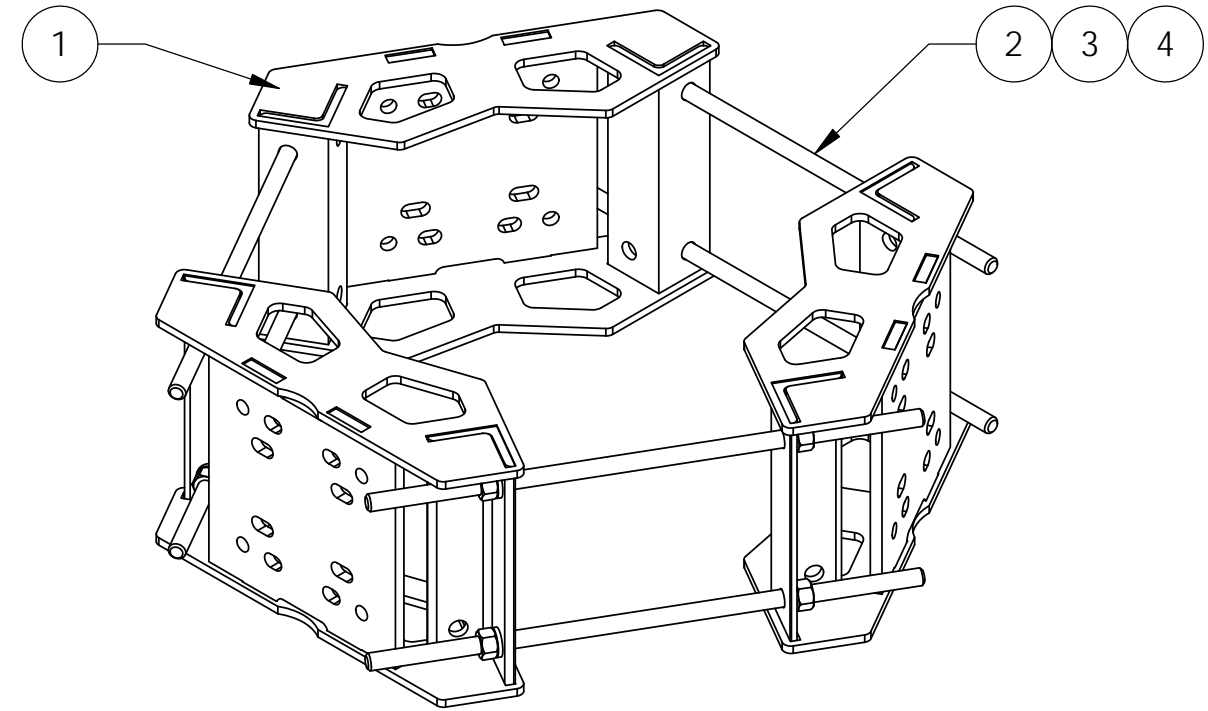
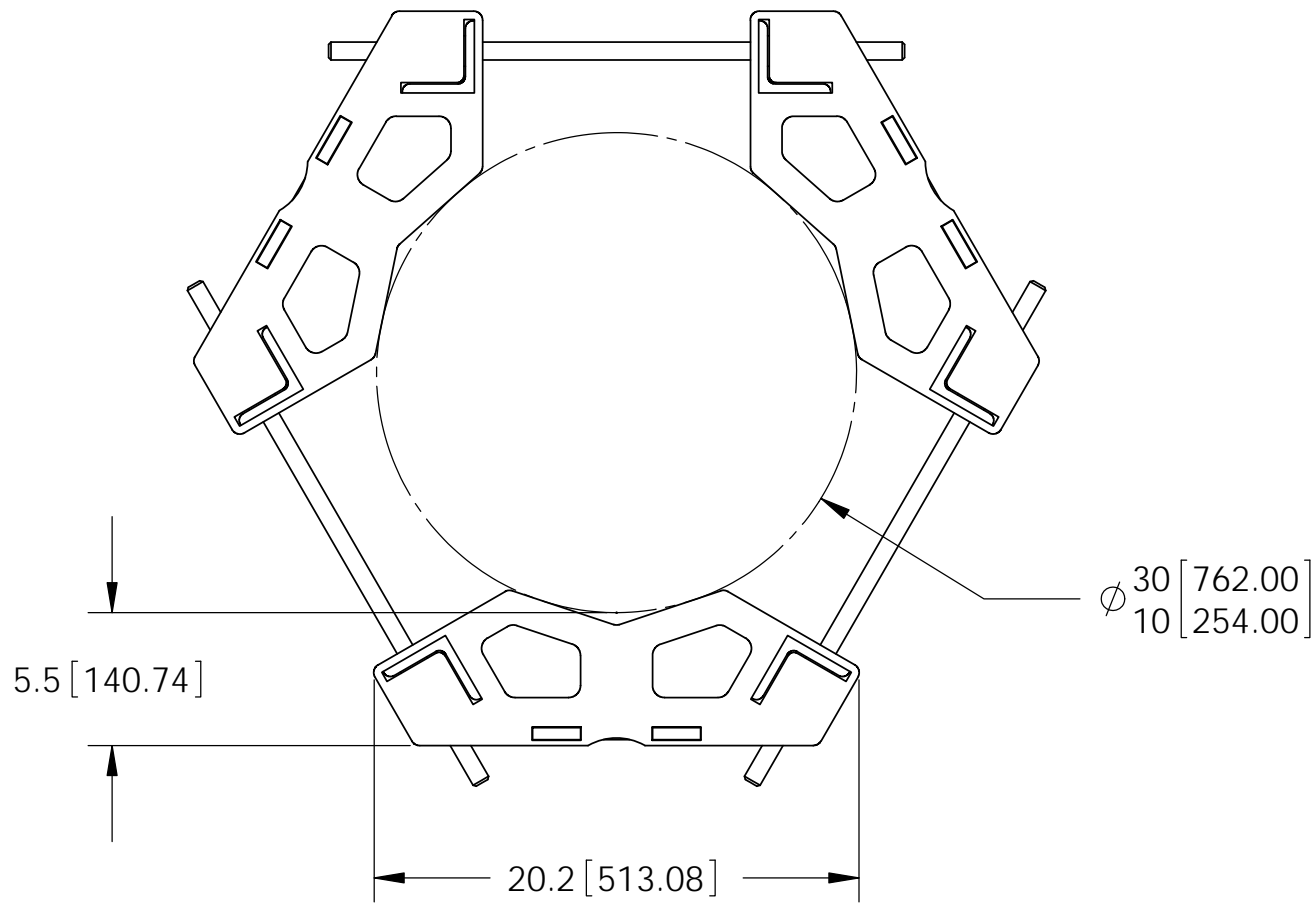

NOTES:
1. ALL METRIC DIMENSIONS ARE IN BRACKETS.

These drawings and specifications are the proprietary property of ANDREW CORPORATION and may be used only for the specific purpose authorized in writing by Andrew Corporation. ALL DIMENSIONS ARE IN INCHES U.O.S. TOLERANCES UNLESS OTHERWISE SPECIFIED: .X = $\pm .12$ ANGLES $\pm 2'$.XX = $\pm .06$ FRACTIONS $\pm 1/32$.XXX = $\pm .03$ REMOVE BURRS AND BREAK EDGES .005 DO NOT SCALE THIS PRINT	DRAWN BY: AW	SHEET: 2 of 2	PART NUMBER: MC-RM1030-3
	CHECKED BY: TP	SCALE: NTS	DESCRIPTION: 10-30 RING MOUNT
	DATE: 08/30/04	MATERIAL: A36, A529	DRAWING TYPE: ASSEMBLY DRAWING
	REVISION: L	FINISH: GALV, A123	WEIGHT: 153.58