

| REVISIONS | | | |
|-----------|---|------------|-------------|
| REV. | DESCRIPTION | DATE | APPROVED |
| A | ECR 8000042867: RELEASE TO PRODUCTION PER EAO 608395. | 21DEC20 RN | KR/KV |
| B | ECR 11777: DRAWING UPDATED. | 23APR21 RN | KR/KV |
| C | ECR 40152755CMO: UPDATE DRAWING WITH LATEST MODEL. | 03AUG22 SL | DM.WANG/WFW |

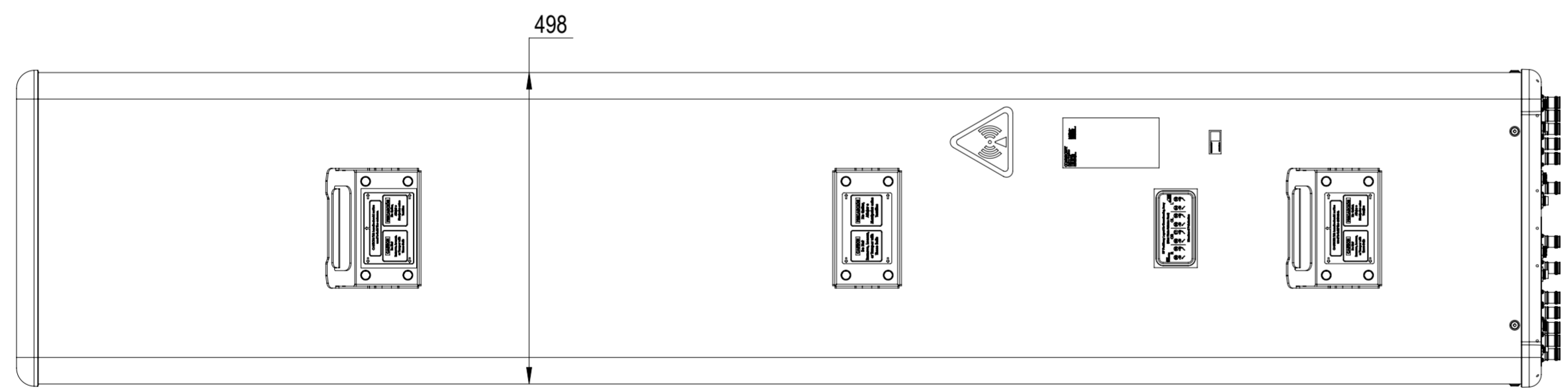
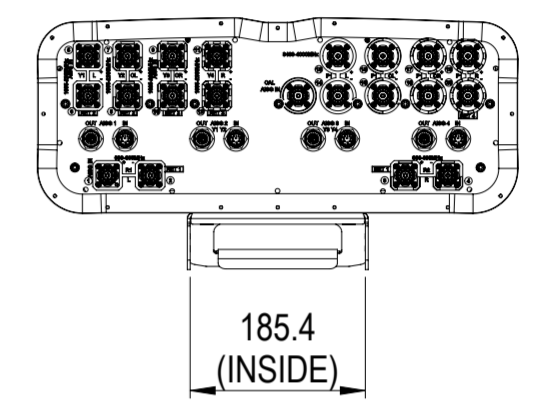
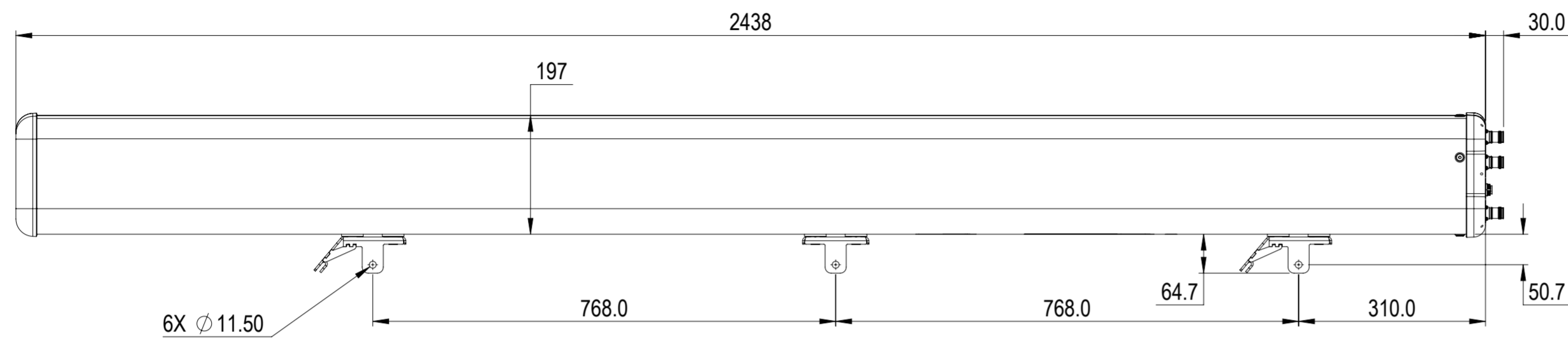

NNH4S4-65C-R4B-V1

COMMScope, INC. OF NORTH CAROLINA

| TOLERANCES | | SAP MATERIAL MASTER | | | | | | | | | | | | | | | |
|--|---------------|---|-------------------------|------|------|-------|-----------|------------|------------------------|-----------|------------|-----------|------------|-----------|------------|-----------------|--|
| 0 PLACE X ± | 2 PLACE .XX ± | | | | | | | | | | | | | | | | |
| 1 PLACE .X ± | ANGLES ± | | | | | | | | | | | | | | | | |
| FINISH | | MATERIAL | | | | | | | | | | | | | | | |
| UNLESS OTHERWISE SPECIFIED DIMENSIONS ARE IN MILLIMETERS INTERPRET PER ISO STANDARDS HANDBOOK TECHNICAL DRAWINGS VOLUMES 1 & 2, THIRD EDITION (2002) | | <table border="1"> <thead> <tr> <th>NAME</th> <th>DATE</th> <th>TITLE</th> </tr> </thead> <tbody> <tr> <td>CE RNAIK2</td> <td>12/22/2020</td> <td rowspan="5" style="text-align: center; vertical-align: middle;">PRODUCT DRAWING</td> </tr> <tr> <td>RW LS1124</td> <td>08/03/2022</td> </tr> <tr> <td>AD DW1030</td> <td>08/18/2022</td> </tr> <tr> <td>RE RY1017</td> <td>08/19/2022</td> </tr> <tr> <td>ECN 40152755CMO</td> <td></td> </tr> </tbody> </table> | | NAME | DATE | TITLE | CE RNAIK2 | 12/22/2020 | PRODUCT DRAWING | RW LS1124 | 08/03/2022 | AD DW1030 | 08/18/2022 | RE RY1017 | 08/19/2022 | ECN 40152755CMO | |
| NAME | DATE | TITLE | | | | | | | | | | | | | | | |
| CE RNAIK2 | 12/22/2020 | PRODUCT DRAWING | | | | | | | | | | | | | | | |
| RW LS1124 | 08/03/2022 | | | | | | | | | | | | | | | | |
| AD DW1030 | 08/18/2022 | | | | | | | | | | | | | | | | |
| RE RY1017 | 08/19/2022 | | | | | | | | | | | | | | | | |
| ECN 40152755CMO | | | | | | | | | | | | | | | | | |
| SCALE 1:8 | | DOCUMENT NO. NNH4S4-65C-R4B-V1-L | | | | | | | | | | | | | | | |
| SIZE A2 | Auth Group | BSA | MODEL | | | | | | | | | | | | | | |
| | | | VERSION STATUS REVISION | | | | | | | | | | | | | | |
| | | | 04 RE E | | | | | | | | | | | | | | |
| | | | VERSION STATUS REVISION | | | | | | | | | | | | | | |
| | | | 02 RE C | | | | | | | | | | | | | | |
| | | | DRAWING SHEET | | | | | | | | | | | | | | |
| | | | 1 OF 1 | | | | | | | | | | | | | | |

| | |
|--------------|-------------------|
| DENSITY | g/mm ³ |
| MASS | grams |
| VOLUME | mm ³ |
| SURFACE AREA | mm ² |
| HEIGHT | |
| LENGTH | |
| WIDTH | |

© 2020 CommScope, Inc.