

| REVISIONS | | | |
|-----------|--|------------|----------|
| REV. | DESCRIPTION | DATE | APPROVED |
| A | ECR 40149118CMP: RELEASE FOR PRODUCTION AS PER EAO 611023. | 02AUG22 AN | MSO/VA |

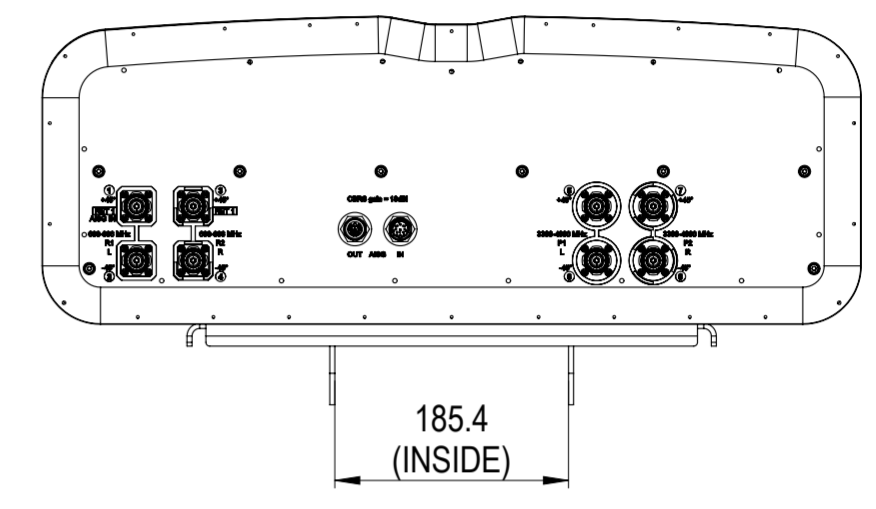
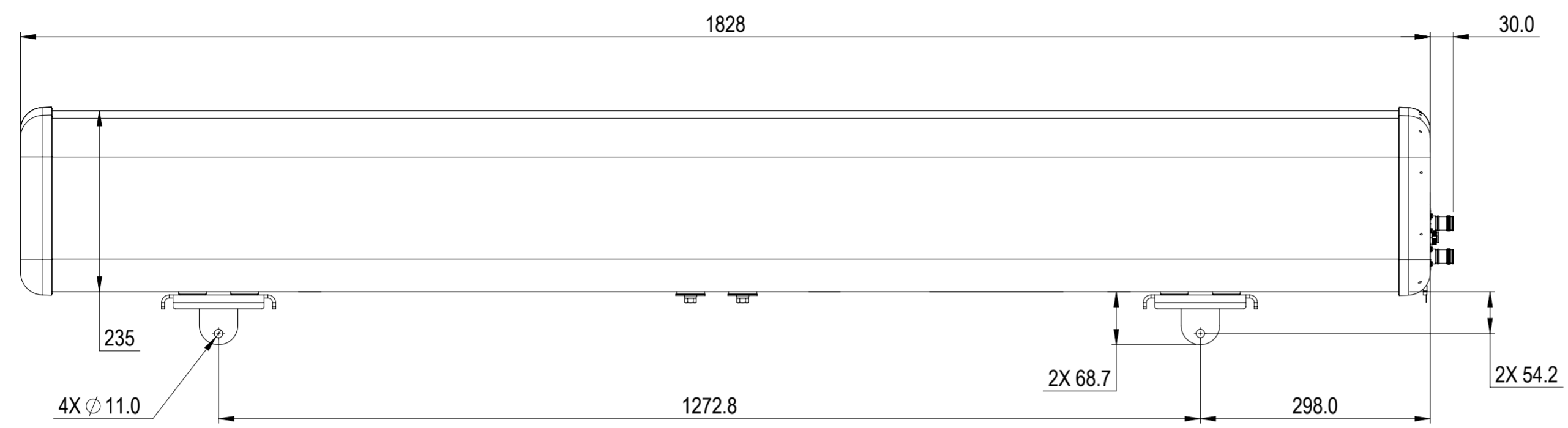

NNSS-45B-R1BT4

COMMSCOPE, INC. OF NORTH CAROLINA

| | | |
|--------------|---------------|---------------------|
| TOLERANCES | | SAP MATERIAL MASTER |
| 0 PLACE X ± | 2 PLACE .XX ± | |
| 1 PLACE .X ± | ANGLES ± | |

| | |
|--------|----------|
| FINISH | MATERIAL |
|--------|----------|

| | | | |
|--|--------------|------------|-------------------------------|
| UNLESS OTHERWISE SPECIFIED DIMENSIONS ARE IN MILLIMETERS INTERPRET PER ISO STANDARDS HANDBOOK TECHNICAL DRAWINGS VOLUMES 1 & 2, THIRD EDITION (2002) | NAME | DATE | TITLE |
| | CE ANAVELKAR | 08/02/2022 | PRODUCT DRAWING |
| | RW ANAVELKAR | 08/05/2022 | |
| | AD MSOGALAD | 08/05/2022 | SCALE 1:6 |
| | RE RK1070 | 08/08/2022 | |
| ECN 40149118CMO | | | DOCUMENT NO. NNSS-45B-R1BT4-L |

| | |
|--------------|-------------------|
| DENSITY | g/mm ³ |
| MASS | grams |
| VOLUME | mm ³ |
| SURFACE AREA | mm ² |
| HEIGHT | |
| LENGTH | |
| WIDTH | |

| | | | | | | | | | |
|------|------------|-----|---------|---------|----------|---------|--------|----------|--------|
| SIZE | Auth Group | BSA | MODEL | DRAWING | | | SHEET | | |
| A2 | | | VERSION | STATUS | REVISION | VERSION | STATUS | REVISION | 1 OF 1 |
| | | | 00 | RE | A | 00 | RE | A | |