

- 1.0 GENERAL NOTES  
 1.1 ALL IMPERIAL DIMENSIONS ARE IN BRACKETS [X.X]  
 1.2 FOR PATENT INFO: <https://www.cs-pat.com>  
 2.0 DESIGN NOTES  
 2.1 ANY HAZARDS OR OBSTRUCTIONS TO THE CLIMBING FACILITY AND SAFETY CLIMB MUST BE IDENTIFIED PRIOR TO INSTALLING THE APPURTENANCE. ADDITIONAL PRODUCTS MAY BE REQUIRED TO MAINTAIN THE INTEGRITY OF THE SAFETY CLIMB. DURING INSTALLATION, TEMPORARY AND/OR PERMANENT PRECAUTIONARY MEASURES SHOULD BE TAKEN TO PRESERVE THE CLIMBING FACILITY AND/OR SAFETY CLIMB.  
 2.2 FITS MONOPOLES 15"-50" O.D.  
 2.3 ANTENNA PIPES SHOULD BE CENTERED AND EVENLY SPACED.  
 2.4 POSITION MOUNT OR ADJUST SAFETY CLIMB CABLE SO NOT TO HINDER OR DAMAGE OR OBSTRUCT THE SAFETY CLIMB. SAFETY CABLE ROUTING BRACKET MAY BE PURCHASED SEPARATELY.  
 2.5 PLEASE REFER TO DOC 7858082 FOR MOUNT CLASSIFICATION.  
 2.6 CABLE GUIDE OPTIONAL KITS: SCG-005, SCG-004 AND SCG-001, PLEASE REFER TO DOC SCG SERIES.  
 3.0 MANUFACTURING/SPECIAL REQUIREMENTS  
 3.1 TIGHTEN ALL BOLTS SECURING FLAT PLATES BY THE TURN-OF-NUT METHOD. TIGHTEN ALL U-BOLTS USING TURN-OF-NUT METHOD WITH ATTENTION TO LEAVE EQUAL DISTANCE AND EQUAL FORCE ON EACH LEG OF THE U-BOLT. ALL FASTENERS SHOULD BE TIGHTENED PER AISC 6.5.2  
 4.0 TEST  
 5.0 PACKAGING  
 5.1 PACKAGING SHALL MEET COMMSCOPE REQUIREMENTS PER DOCUMENT IS-PL-3005  
 5.2 PRINTED DOCUMENT TO BE PLACED INSIDE POLYBAG AND THEN IN SHIPPING CONTAINER  
 5.3 EXTRA HARDWARE MAYBE SUPPLIED, BAGGED AND SHIPPED

REVISIONS			
REV.	DESCRIPTION	DATE	APPROVED
A	INITIAL RELEASE	JL1183 15MAY23	CB1094 40162835CMO

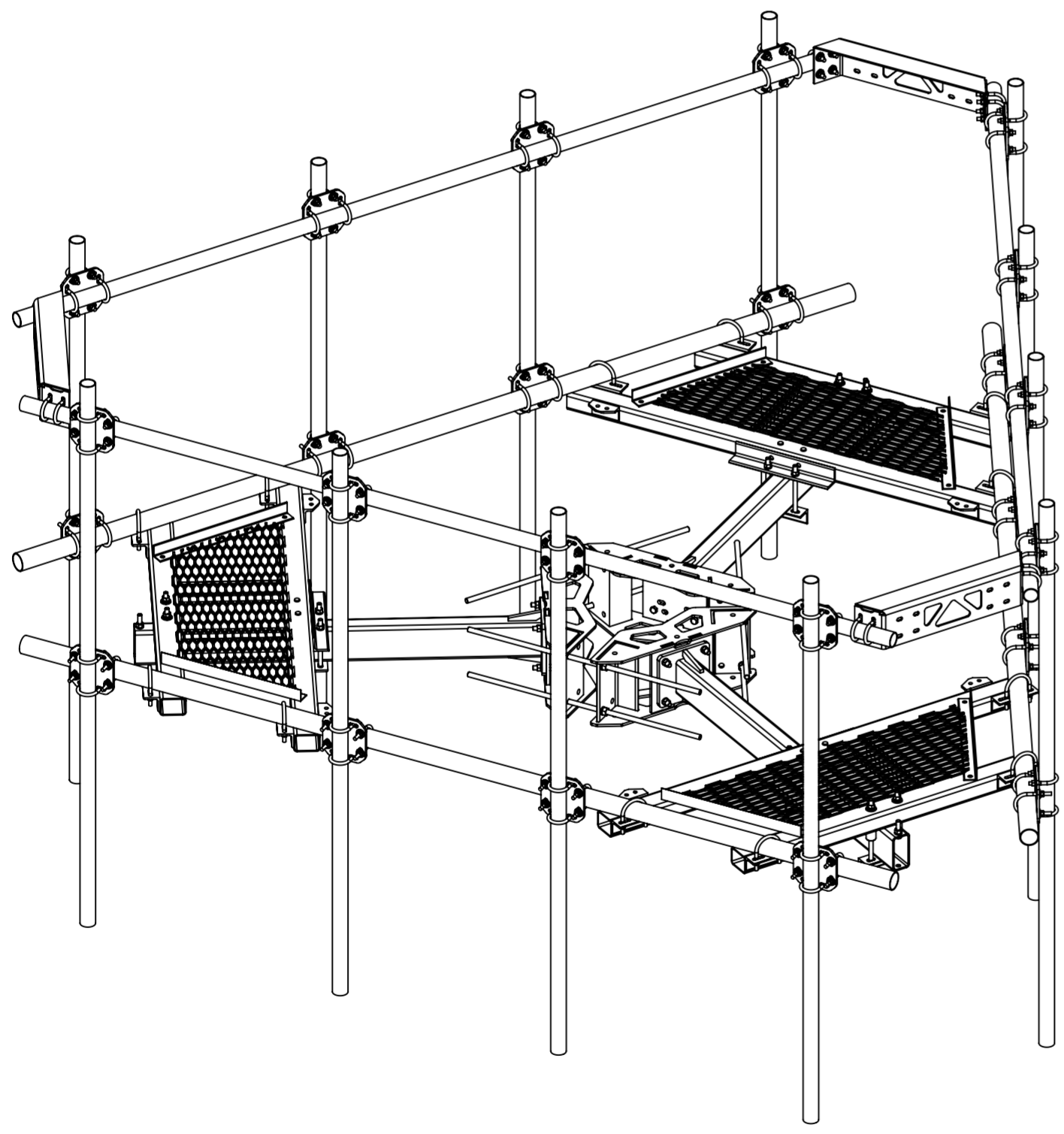
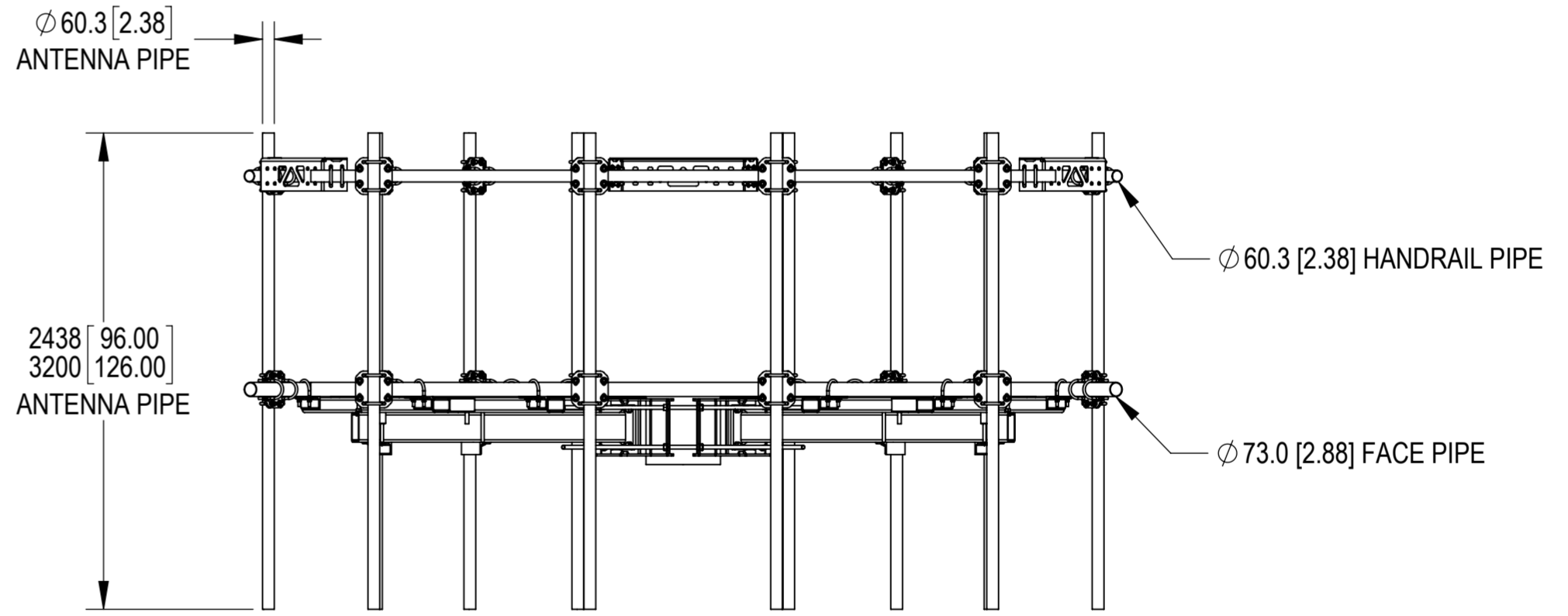
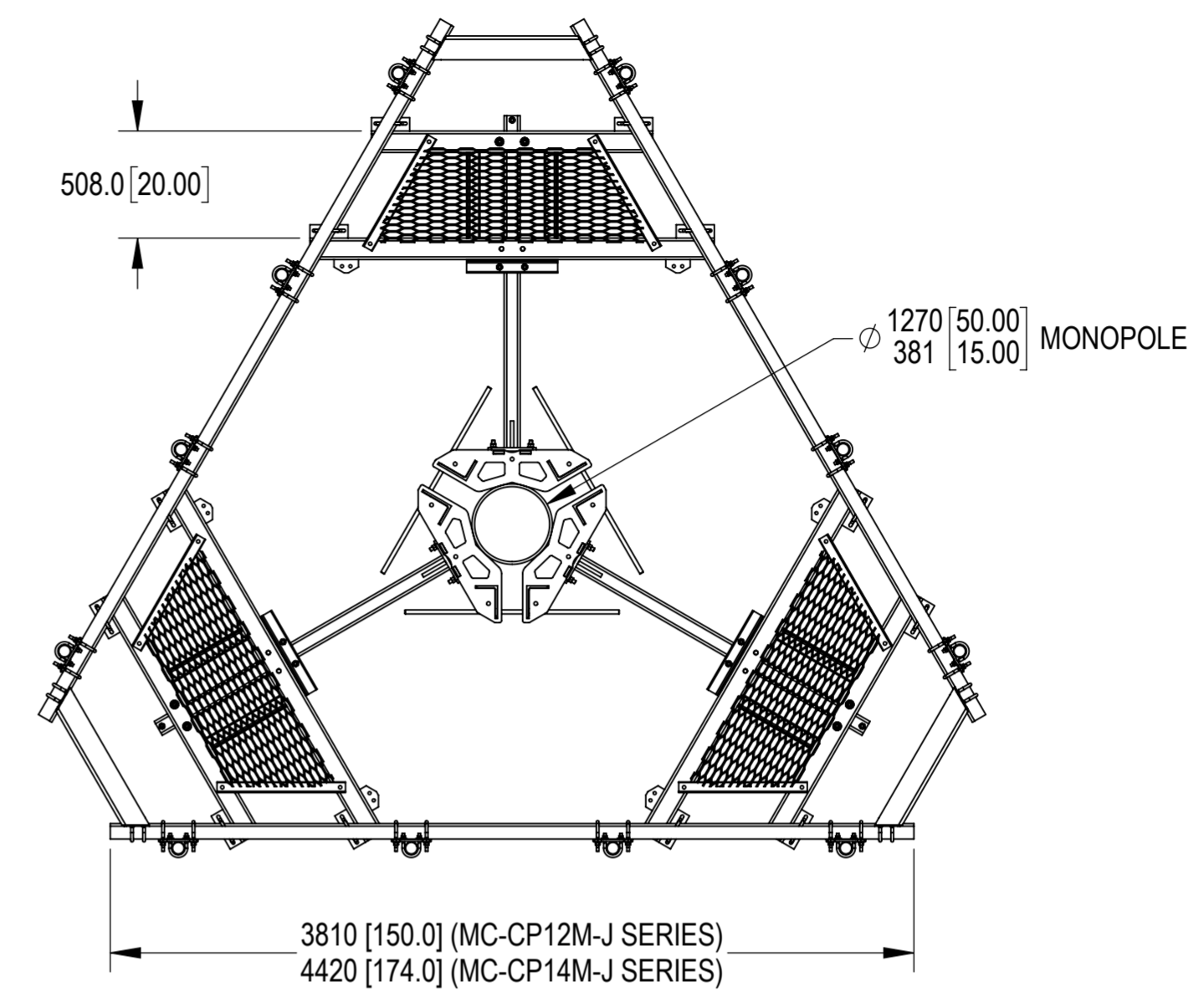

MONOPOLE ADJUSTABLE PLATFORM  
 MC-CP12M-12-96-J SHOWN FOR REFERENCE  
 (SEE TABLE 1 FOR ALL CONFIGURATIONS)

COMMSCOPE, INC. OF NORTH CAROLINA

TOLERANCES		SAP MATERIAL MASTER	
0 PLACE X[X] ± 6[0.25]	2 PLACE .XX[.XXX] ± 1.50[0.06]	SEE TABLE 1	
1 PLACE .X[.XX] ± 3.0[0.12]	ANGLES ± 2°		

FINISH	MATERIAL		
--------	----------	--	--

DENSITY	lbs/in <sup>3</sup>
MASS	lbs
VOLUME	in <sup>3</sup>
SURFACE AREA	in <sup>2</sup>
DENSITY	g/mm <sup>3</sup>
MASS	grams
VOLUME	mm <sup>3</sup>
SURFACE AREA	mm <sup>2</sup>
HEIGHT	
LENGTH	
WIDTH	

UNLESS OTHERWISE SPECIFIED DIMENSIONS ARE IN MILLIMETERS INTERPRET PER ANSI Y 14.5M-1994	NAME	DATE	TITLE
	CE JL1183	15MAY23	ADJ PLATFORM HR SERIES
	RW JL1183	05/24/2023	
	AD CB1094	05/24/2023	SCALE
	RE JL1183	05/24/2023	DOCUMENT NO.
ECN 40162835CMO			MC-CP-J

SIZE	Auth Group	INSL	MODEL	DRAWING			SHEET
A2			VERSION	STATUS	REVISION	VERSION	STATUS
			03	RE	D	00	RE
							A
							1 OF 11

# PART NUMBERS, WEIGHTS, & EPA

## TABLE 1: CONFIGURATIONS

PART NUMBER	DESCRIPTION	WEIGHT (LBS)	(EPA)A (FT^2)*	(EPA)A 1/2" ICE THICKNESS (FT^2)*	ANTENNA PIPES	INCLUDED PARTS																		
						MC-RM1550-3	MC-AS-SB01	MC-AS-1200-00	9615-13	9615-14	GWL05HB20	GN05HB20	GB-05245	GUB-4355-12	MT197H	MT546150120	MT546174120	HRK-12-12-02	HRK-14-12-02	XP-2020-12	XP-2025-12	MT-651-96	MT-537	
MC-CP12M-B-J	ADJ PLATFORM 12' FACE BASE-KIT HR	1276.3	26.0	33.5	-	1	1	6	6	6	1	1	3	1	3	3	-	1	-	1	1	12	-	
MC-CP12M-12-96-J	ADJ PLATFORM 12' FACE 12-96" PIPE HR	1745.4			12	1	1	6	6	6	1	1	3	1	3	3	-	1	-	1	1	1	12	-
MC-CP12M-12-126-J	ADJ PLATFORM 12' FACE 12-126" PIPE HR	1831.8			12	1	1	6	6	6	1	1	3	1	3	3	-	1	-	1	1	1	1	12
MC-CP14M-B-J	ADJ PLATFORM 14' FACE BASE-KIT HR	1870.5	27.4	35.4	-	1	1	6	6	6	1	1	3	1	3	-	3	-	1	-	-	-	-	
MC-CP14M-12-96-J	ADJ PLATFORM 14' FACE 12-96" PIPE HR	1784.1			12	1	1	6	6	6	1	1	3	1	3	-	3	-	1	1	1	1	12	-
MC-CP14M-12-126-J	ADJ PLATFORM 14' FACE 12-126" PIPE HR	1315.0			12	1	1	6	6	6	1	1	3	1	3	-	3	-	1	1	1	1	1	12

\* (EPA)A DOES NOT INCLUDE ANTENNA PIPES AND MOUNTING HARDWARE. IF DESIRED, ADD ANTENNA PIPE PER TABLE 2

## TABLE 2: EPA OF EACH ANTENNA PIPE

ANTENNA PIPE	(EPA)A (FT^2)	(EPA)A W/ 1/2" ICE THICKNESS (FT^2)
2-3/8" X 96"	1.52	2.16
2-3/8" X 126"	2.00	2.84

- NOTE:
- ANTENNA PIPES ARE CONSIDERED SEPARATELY.
  - KA FACTOR OF 3-SECTOR EPA INCLUDED.
  - COMBINE THE ASSOCIATED EPA VALUES IN THE TABLES ABOVE TO DETERMINE THE EPA OF A MOUNT MODEL WITH A LISTED MOUNT PIPE CONFIGURATION. FOR EXAMPLE, MC-CP12M-12-96-J HAS A 3-SECTOR EPA OF 26.0 FT2 WITH NO ICE PLUS 12 ANTENNA PIPES WITH A 3-SECTOR EPA OF 12X1.52=18.2 FT2 WITH NO ICE. SO, THE TOTAL EPA OF 44.2 FT2 FOR THE MC-CP12M-12-96-J.

COMMSCOPE, INC. OF NORTH CAROLINA				
TITLE ADJ PLATFORM HR SERIES				
SIZE <b>A2</b>	SCALE <b>1:30</b>	DOCUMENT NO. <b>MC-CP-J</b>		
DRAWING				SHEET
VERSION 00	STATUS RE	REVISION A	2 OF 11	

# PLATFORM FOR INSTALLATION

ADJUST THE INSTALLATION DISTANCE ACCORDING TO THE DIAMETER OF THE MONOPOLE WHEN INSTALL PLATFORM MC-AS-1100-00.  
SEE TABLE 3 DETAIL FOR THE DISTANCE ADJUSTED.

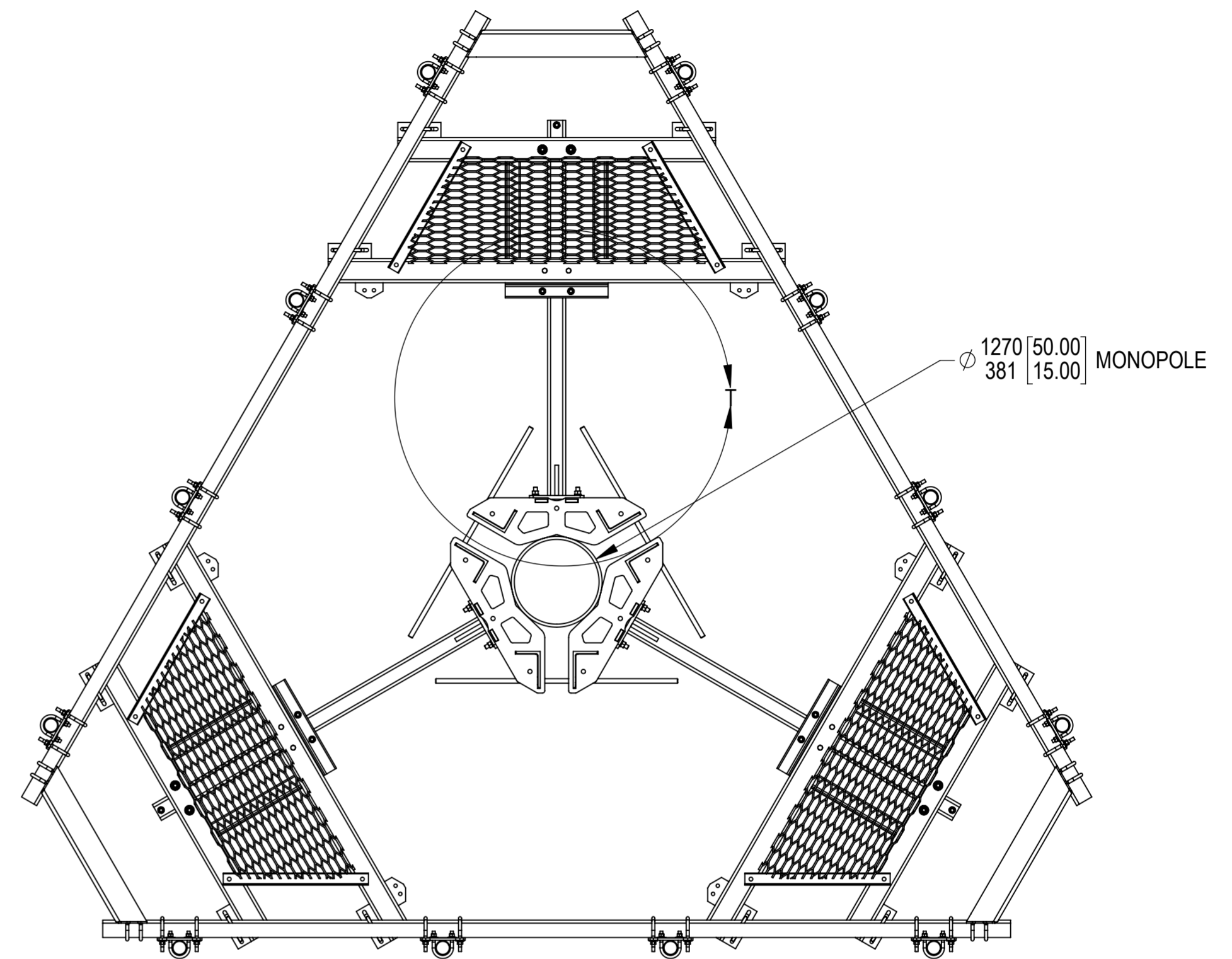
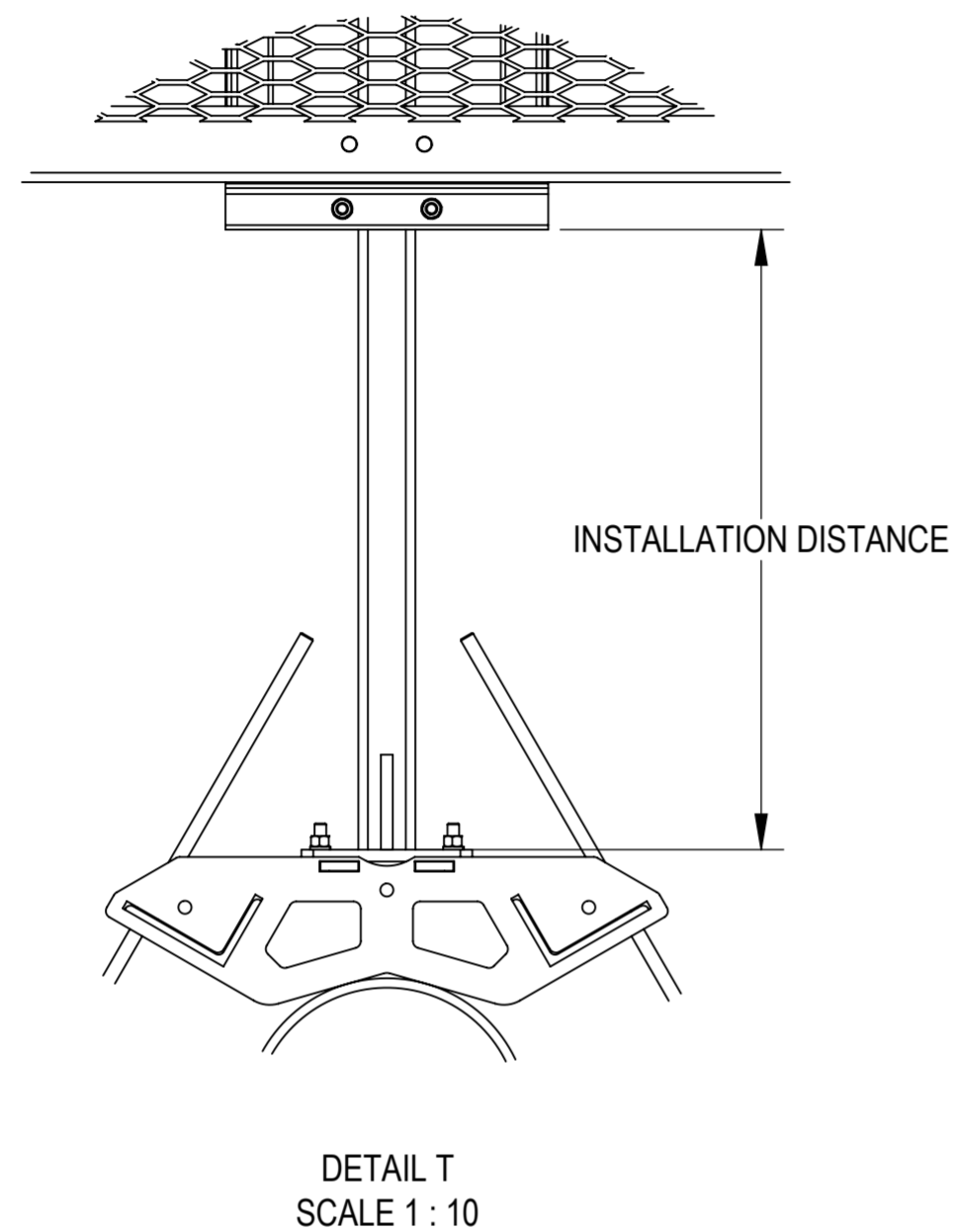

MC-CP12M-12-96-J SHOWN FOR REFERENCE  
(SEE TABLE 1 FOR ALL CONFIGURATIONS)

TABLE 3: PLATFORM INSTALLATION POSITION

DIAMETER OF MONOPOLE (INCH)	DISATNCE (INCH)	DIAMETER OF MONOPOLE (MM)	DISATNCE (MM)
15	32.64	381.0	829.2
17.5	31.34	444.5	796.1
20	30.04	508.0	763.1
22.5	28.74	571.5	730.1
25	27.44	635.0	697.1
27.5	26.14	698.5	664.0
30	24.84	762.0	631.0
32.5	23.54	825.5	598.0
35	22.24	889.0	564.9
37.5	20.94	952.5	531.9
40	19.64	1016.0	498.9
42.5	18.34	1079.5	465.9
45	17.04	1143.0	432.8
47.5	15.74	1206.5	399.8
50	14.44	1270.0	366.8

NOTE: FOR MONOPOLE DIAMETERS THAT ARE NOT IN THE TABLE, USE BELOW FORMULA TO GET THE VALUE OF THE ADJUSTMENT:  
DISTANCE OF ADJUSTMENT = 40.45 - 0.52\*D (INCH), WHERE D(INCH) IS THE DIAMETER OF MONOPOLE

COMMSCOPE, INC. OF NORTH CAROLINA			
TITLE			
ADJ PLATFORM HR SERIES			
SIZE	SCALE	DOCUMENT NO.	
A2	1:20	MC-CP-J	
DRAWING			SHEET
VERSION	STATUS	REVISION	3 OF 11
00	RE	A	

COMPONENTS FOR INSTALLATION  
MC-CP12M-B-J SHOWN ON THIS PAGE

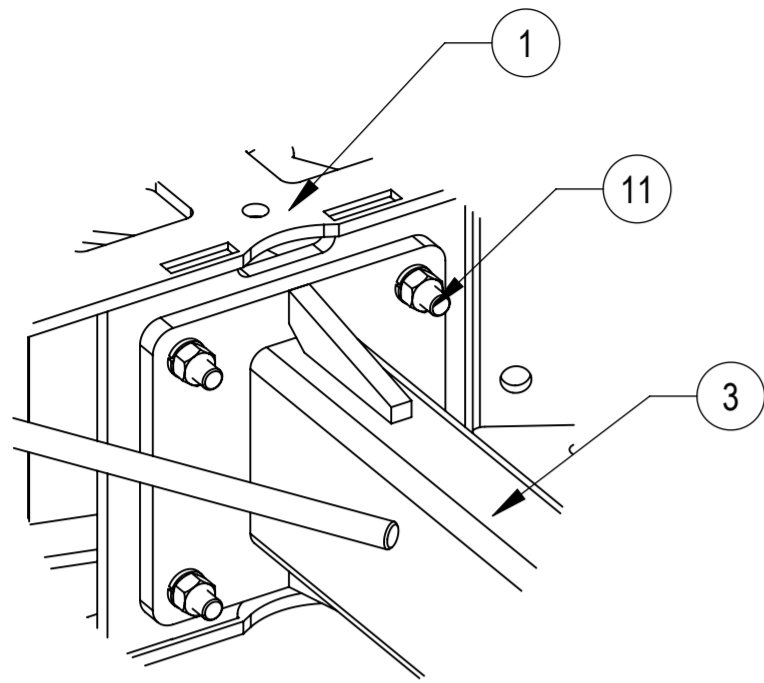

DETAIL A  
SCALE 1 : 5

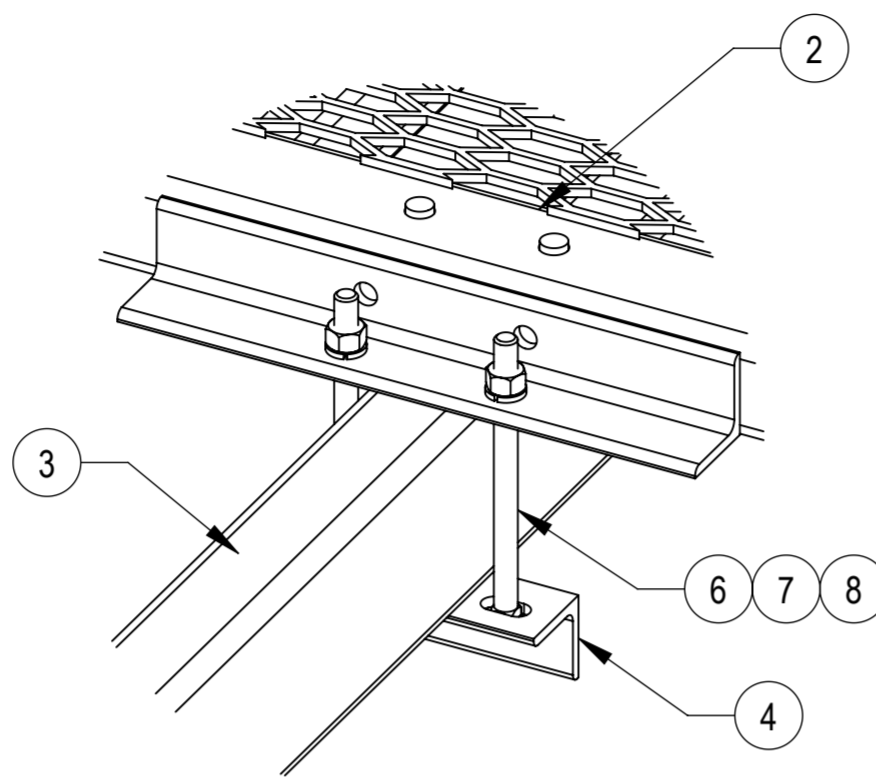

DETAIL B  
SCALE 1 : 5

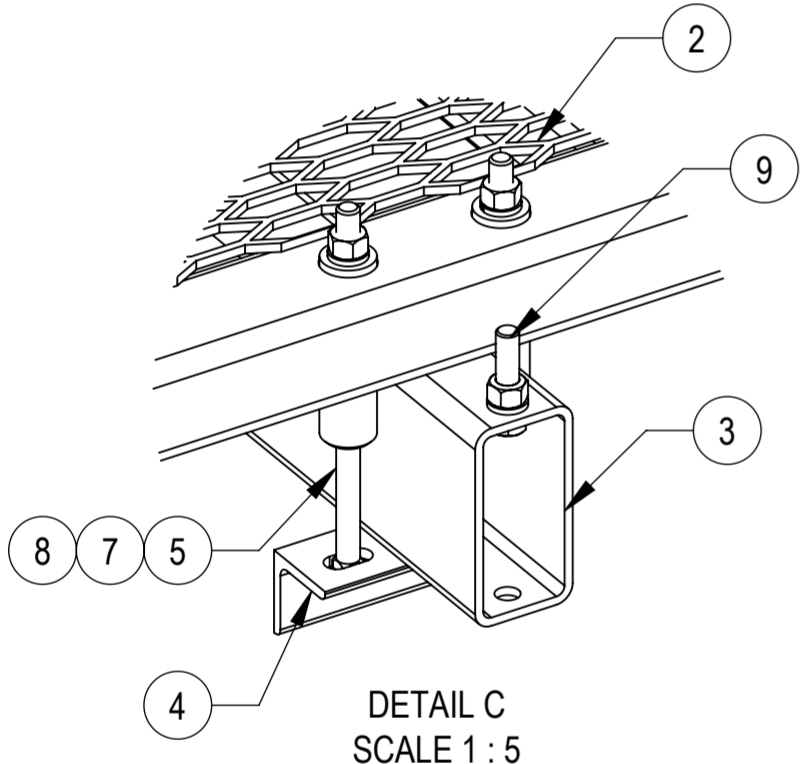

DETAIL C  
SCALE 1 : 5

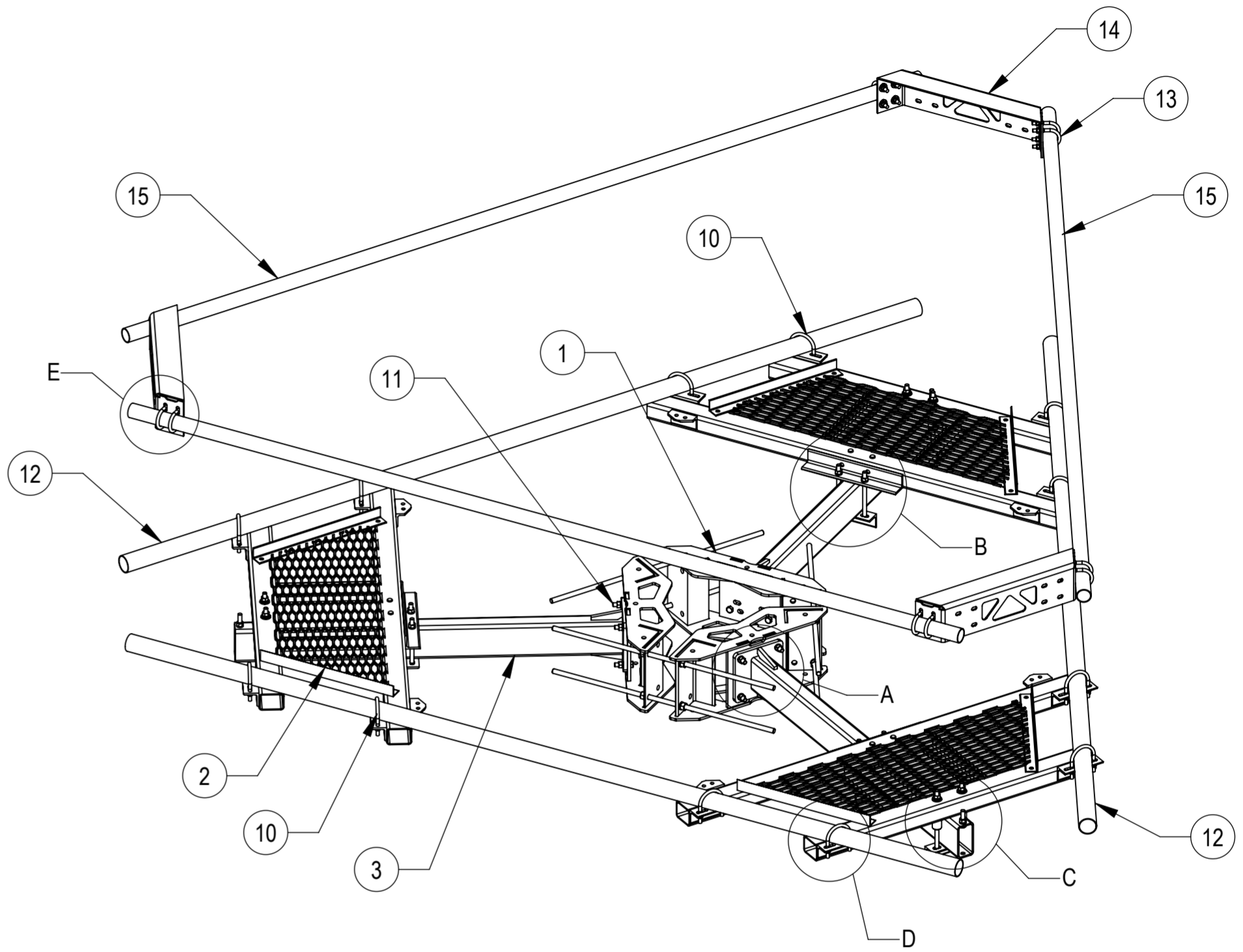

COMPONENT PART NUMBERS PROVIDED FOR ASSEMBLY PURPOSES;  
INDIVIDUAL COMPONENTS MAY BE SHIPPED AS PARTS WITHIN AN INCLUDED KIT.

ITEM NO.	PART NUMBER	DESCRIPTION	QTY.	WEIGHT	NOTE NO.
1	MC-RM1550-3	15" - 50" OD RINGMOUNT	1	229.90 LBS	
2	MC-AS-1100-00	WELDMENT, CO-LOCATION PLATFORM FRAME	3	145.67 LBS	
3	MC-AS-2000-00	WELDMENT, T-ARM SPINDLE	3	85.79 LBS	
4	MC-AS-1200-00	CLAMP PLATE, CO-LOCATION PLATFORM	6	2.93 LBS	
5	9615-13	BOLT,CARRIAGE,5/8-11,11,STL GALV	6	0.13 LBS	
6	9615-14	BOLT,CARRIAGE,5/8-11,8.5,STL GALV	6	0.11 LBS	
7	GWL-05	5/8" GALV LOCK WASHER	12	0.03 LBS	
8	GN-05	5/8" GALV HEX NUT	12	0.08 LBS	
9	GB-05245	5/8" X 2-1/2" GALV BOLT KIT	3	0.304 LBS	
10	GUB-4355	1/2" X 3-5/8" X 5" GALV U-BOLT	12	0.71 LBS	
11	GB-0524A	5/8" X 2-1/2" GALV BOLT KIT (A325)	12	0.305 LBS	
12	MT546150120	2.88 OD X 150" LONG PIPE	3	44.29 LBS	
13	GUB-4240	1/2" X 2-1/2" X 4" GALV U-BOLT	12	0.56 LBS	
14	MC-AS-3600-00	CORNER WELDMENT, HANDRAIL	3	20.75 LBS	
15	MT-651-150	2.375" OD X 150" PIPE	3	36.34 LBS	

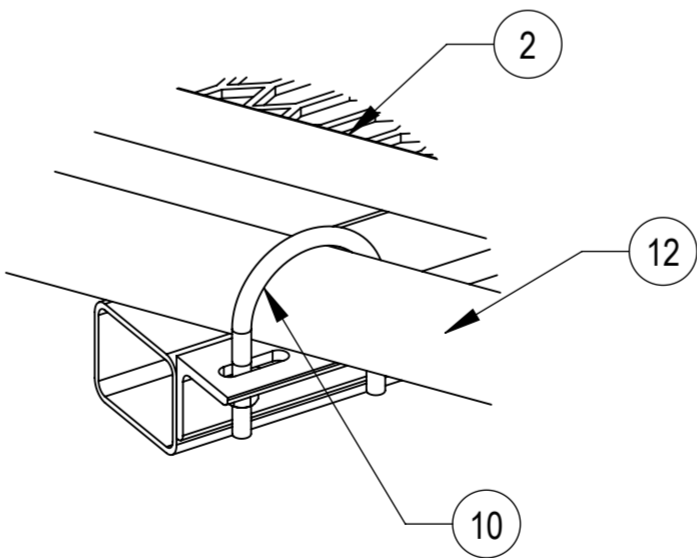

DETAIL D  
SCALE 1 : 5

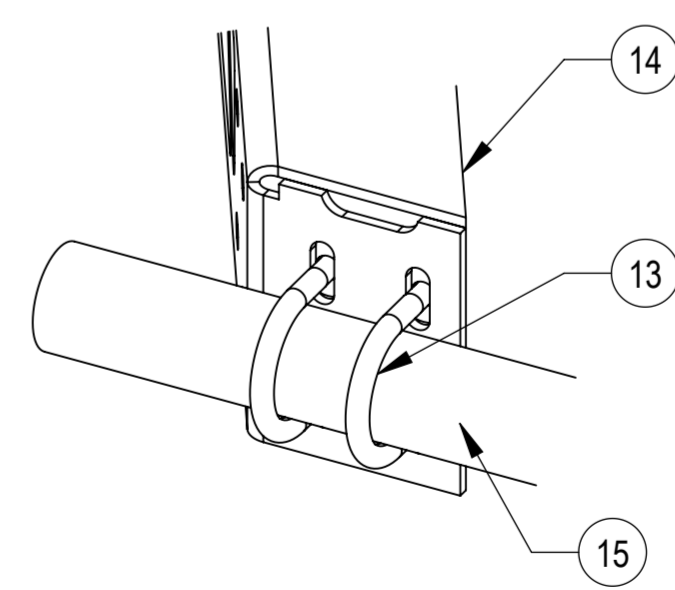

DETAIL E  
SCALE 1 : 4

COMMSCOPE, INC. OF NORTH CAROLINA				
TITLE ADJ PLATFORM HR SERIES				
SIZE A2	SCALE 1:20	DOCUMENT NO. MC-CP-J		
DRAWING		SHEET		
VERSION 00	STATUS RE	REVISION A	4 OF 11	

COMPONENTS FOR INSTALLATION  
MC-CP12M-12-96-J SHOWN ON THIS PAGE

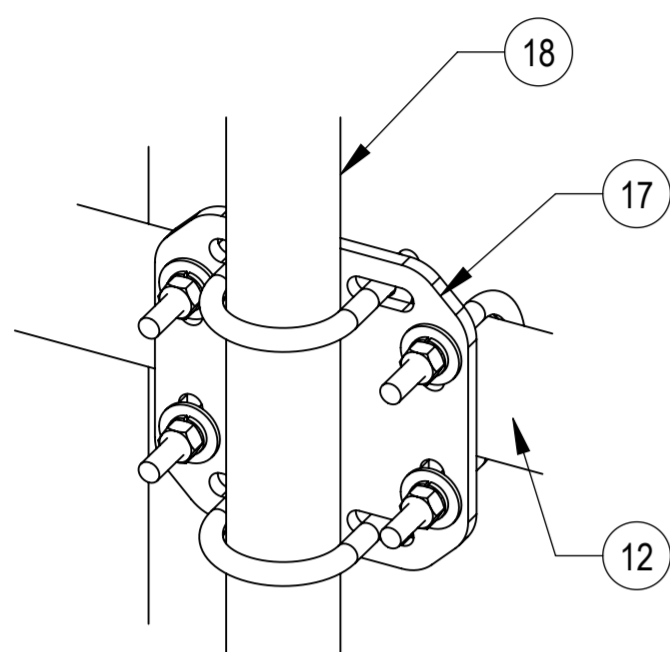

DETAIL F  
SCALE 1 : 4

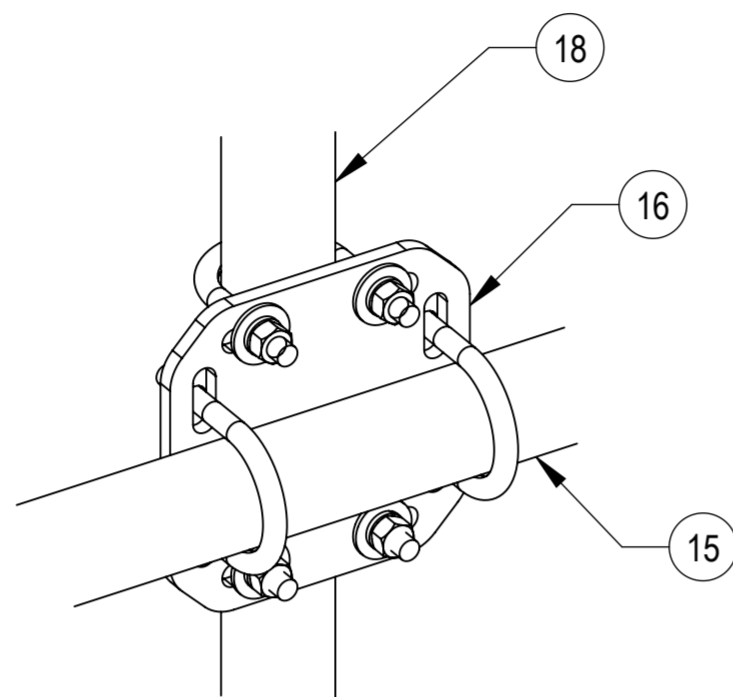

DETAIL G  
SCALE 1 : 4

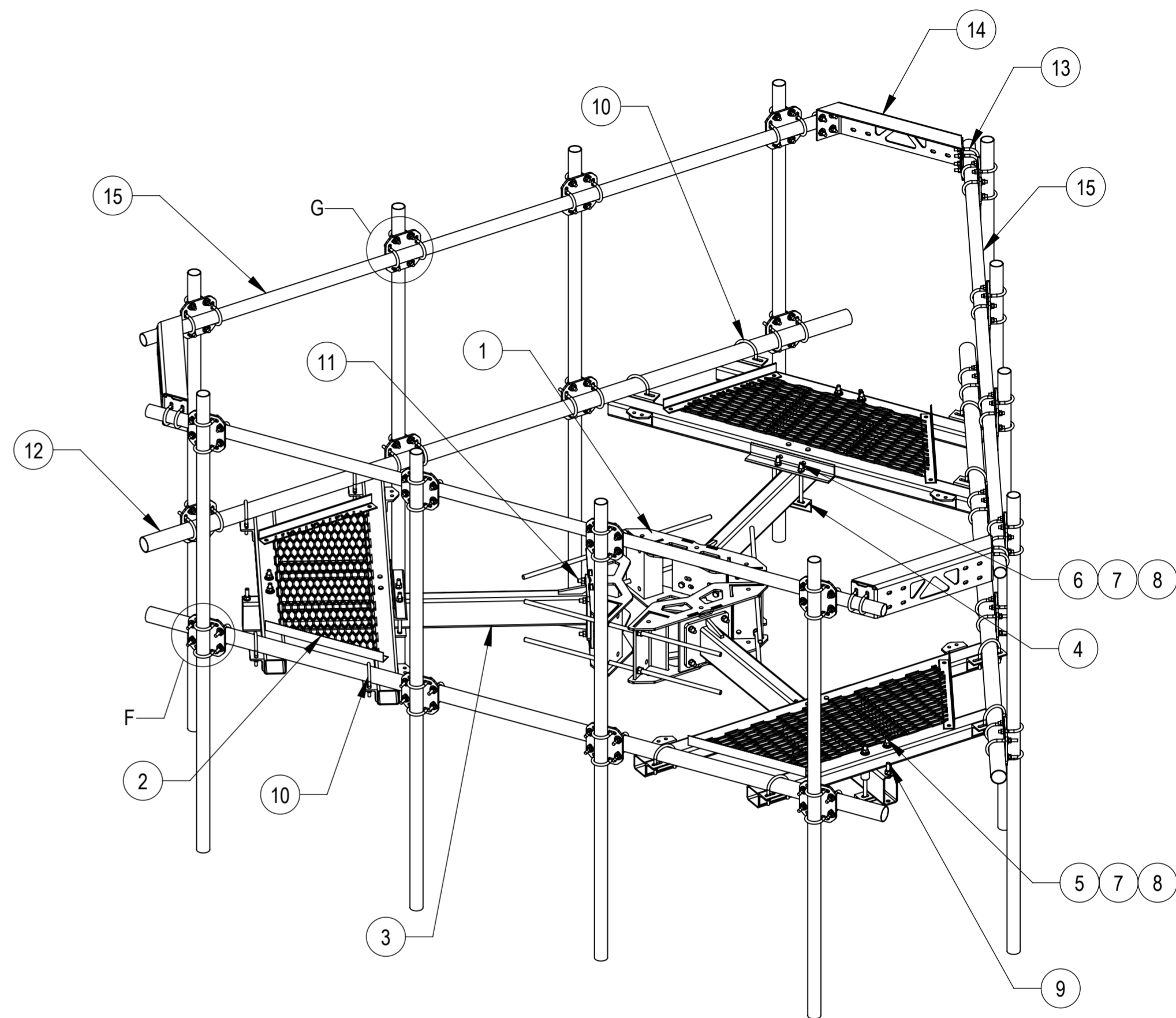

COMPONENT PART NUMBERS PROVIDED FOR ASSEMBLY PURPOSES;  
INDIVIDUAL COMPONENTS MAY BE SHIPPED AS PARTS WITHIN AN INCLUDED KIT.

ITEM NO.	PART NUMBER	DESCRIPTION	QTY.	WEIGHT	NOTE NO.
1	MC-RM1550-3	15" - 50" OD RINGMOUNT	1	229.90 LBS	
2	MC-AS-1100-00	WELDMENT, CO-LOCATION PLATFORM FRAME	3	145.67 LBS	
3	MC-AS-2000-00	WELDMENT, T-ARM SPINDLE	3	85.79 LBS	
4	MC-AS-1200-00	CLAMP PLATE, CO-LOCATION PLATFORM	6	2.93 LBS	
5	9615-13	BOLT,CARRIAGE,5/8-11,11,STL GALV	6	0.13 LBS	
6	9615-14	BOLT,CARRIAGE,5/8-11,8.5,STL GALV	6	0.11 LBS	
7	GWL-05	5/8" GALV LOCK WASHER	12	0.03 LBS	
8	GN-05	5/8" GALV HEX NUT	12	0.08 LBS	
9	GB-05245	5/8" X 2-1/2" GALV BOLT KIT	3	0.304 LBS	
10	GUB-4355	1/2" X 3-5/8" X 5" GALV U-BOLT	12	0.71 LBS	
11	GB-0524A	5/8" X 2-1/2" GALV BOLT KIT (A325)	12	0.305 LBS	
12	MT546150120	2.88 OD X 150" LONG PIPE	3	44.29 LBS	
13	GUB-4240	1/2" X 2-1/2" X 4" GALV U-BOLT	12	0.56 LBS	
14	MC-AS-3600-00	CORNER WELDMEMT, HANDRAIL	3	20.75 LBS	
15	MT-651-150	2.375" OD X 150" PIPE	3	36.34 LBS	
16	XP-2020	CROSSOVER PLATE KIT, 2-3/8 OD X 2-3/8 OD	12	7.77 LBS	
17	XP-2025	CROSSOVER PLATE KIT, 2-3/8 OD X 2-7/8 OD	12	8.07 LBS	
18	MT-651-96	2.375" OD X 96" PIPE	12	23.05 LBS	

COMMSCOPE, INC. OF NORTH CAROLINA				
TITLE ADJ PLATFORM HR SERIES				
SIZE A2	SCALE 1:20	DOCUMENT NO. MC-CP-J		
DRAWING				SHEET
VERSION 00	STATUS RE	REVISION A	5 OF 11	

COMPONENTS FOR INSTALLATION  
MC-CP12M-12-126-J SHOWN ON THIS PAGE

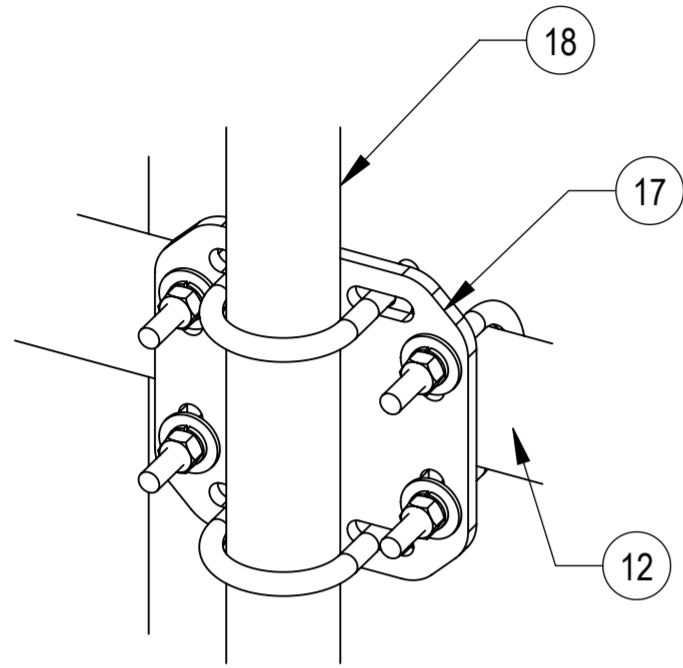

DETAIL H  
SCALE 1 : 4

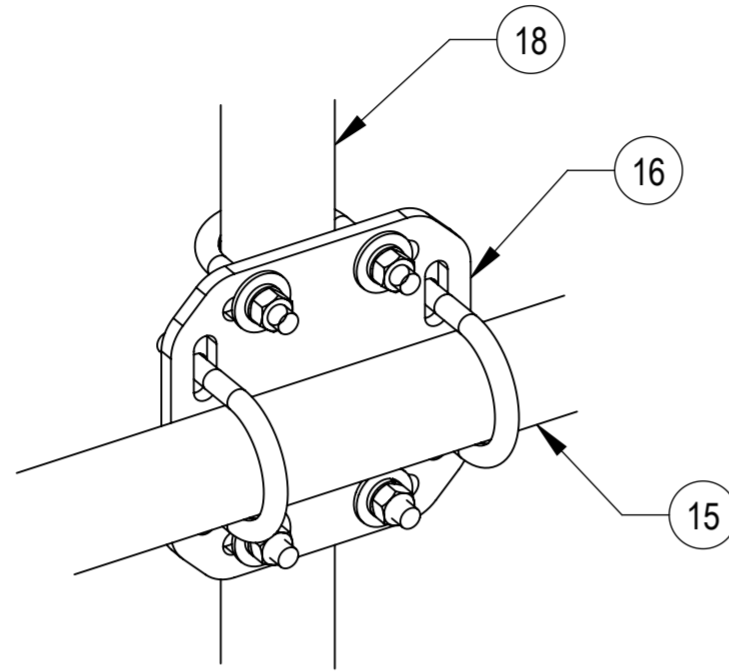

DETAIL J  
SCALE 1 : 4

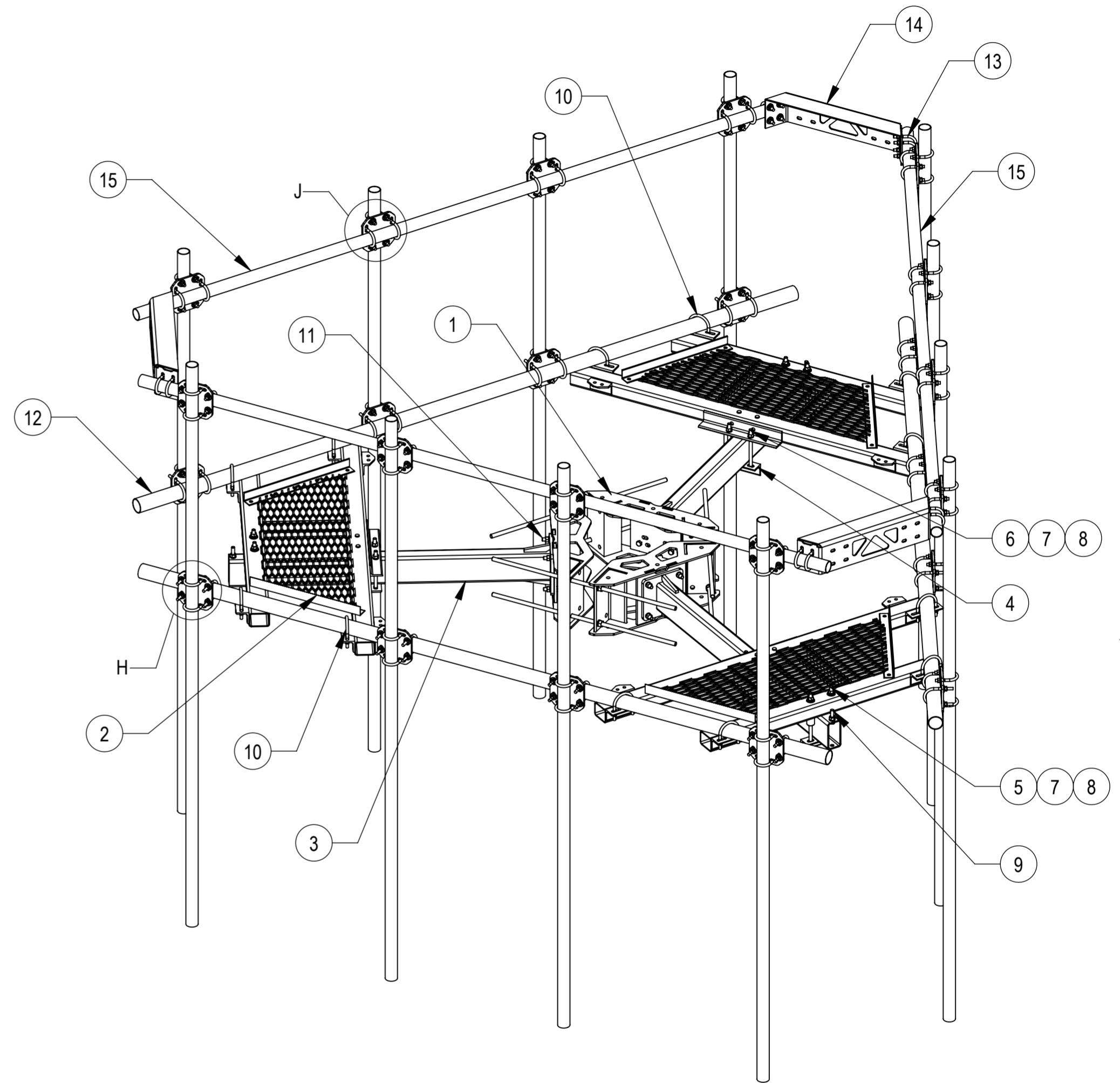

COMPONENT PART NUMBERS PROVIDED FOR ASSEMBLY PURPOSES;  
INDIVIDUAL COMPONENTS MAY BE SHIPPED AS PARTS WITHIN AN INCLUDED KIT.

ITEM NO.	PART NUMBER	DESCRIPTION	QTY.	WEIGHT	NOTE NO.
1	MC-RM1550-3	15" - 50" OD RINGMOUNT	1	229.90 LBS	
2	MC-AS-1100-00	WELDMENT, CO-LOCATION PLATFORM FRAME	3	145.67 LBS	
3	MC-AS-2000-00	WELDMENT, T-ARM SPINDLE	3	85.79 LBS	
4	MC-AS-1200-00	CLAMP PLATE, CO-LOCATION PLATFORM	6	2.93 LBS	
5	9615-13	BOLT,CARRIAGE,5/8-11,11,STL GALV	6	0.13 LBS	
6	9615-14	BOLT,CARRIAGE,5/8-11,8.5,STL GALV	6	0.11 LBS	
7	GWL-05	5/8" GALV LOCK WASHER	12	0.03 LBS	
8	GN-05	5/8" GALV HEX NUT	12	0.08 LBS	
9	GB-05245	5/8" X 2-1/2" GALV BOLT KIT	3	0.304 LBS	
10	GUB-4355	1/2" X 3-5/8" X 5" GALV U-BOLT	12	0.71 LBS	
11	GB-0524A	5/8" X 2-1/2" GALV BOLT KIT (A325)	12	0.305 LBS	
12	MT546150120	2.88 OD X 150" LONG PIPE	3	44.29 LBS	
13	GUB-4240	1/2" X 2-1/2" X 4" GALV U-BOLT	12	0.56 LBS	
14	MC-AS-3600-00	CORNER WELDMEMT, HANDRAIL	3	20.75 LBS	
15	MT-651-150	2.375" OD X 150" PIPE	3	36.34 LBS	
16	XP-2020	CROSSOVER PLATE KIT, 2-3/8 OD X 2-3/8 OD	12	7.77 LBS	
17	XP-2025	CROSSOVER PLATE KIT, 2-3/8 OD X 2-7/8 OD	12	8.07 LBS	
18	MT-537	2.375" OD x 126" PIPE	12	30.45 LBS	

COMMSCOPE, INC. OF NORTH CAROLINA				
TITLE ADJ PLATFORM HR SERIES				
SIZE A2	SCALE 1:20	DOCUMENT NO. MC-CP-J		
DRAWING		SHEET		
VERSION 00	STATUS RE	REVISION A	6 OF 11	

COMPONENTS FOR INSTALLATION  
MC-CP14M-B-J SHOWN ON THIS PAGE

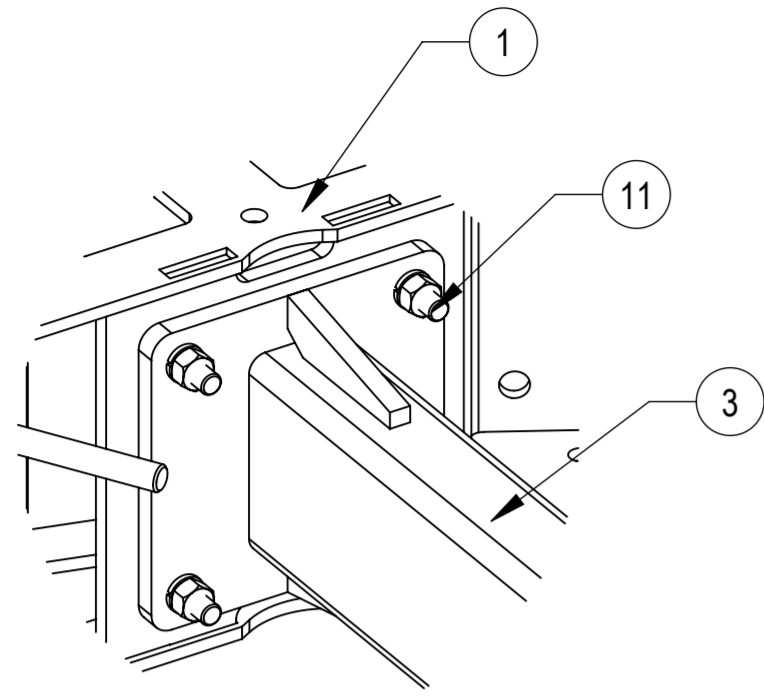

DETAIL K  
SCALE 1 : 5

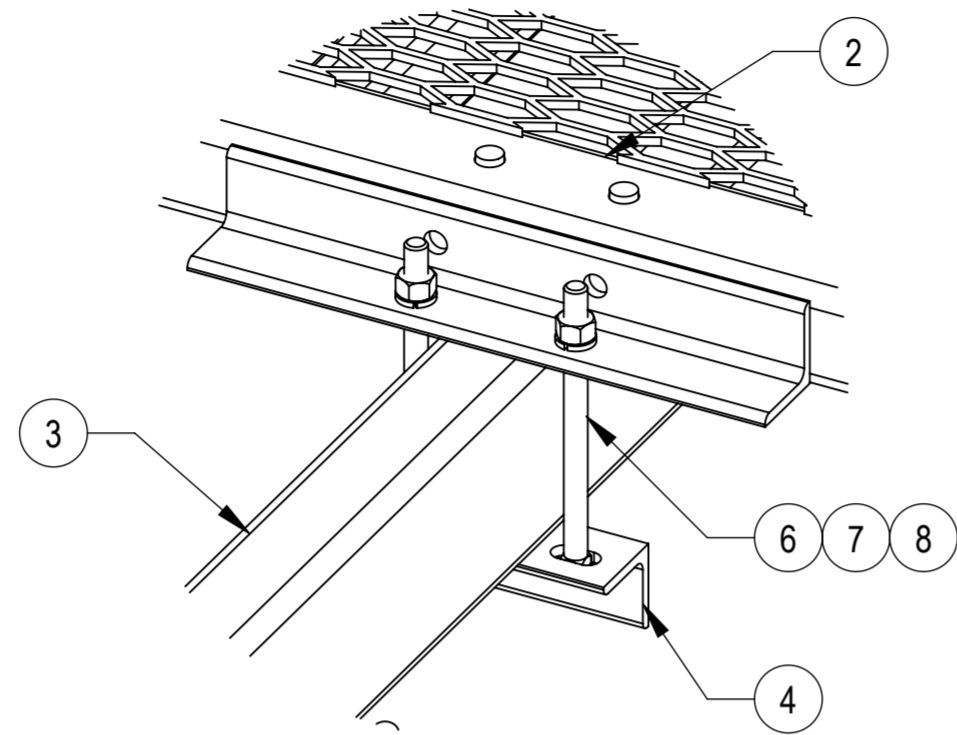

DETAIL L  
SCALE 1 : 5

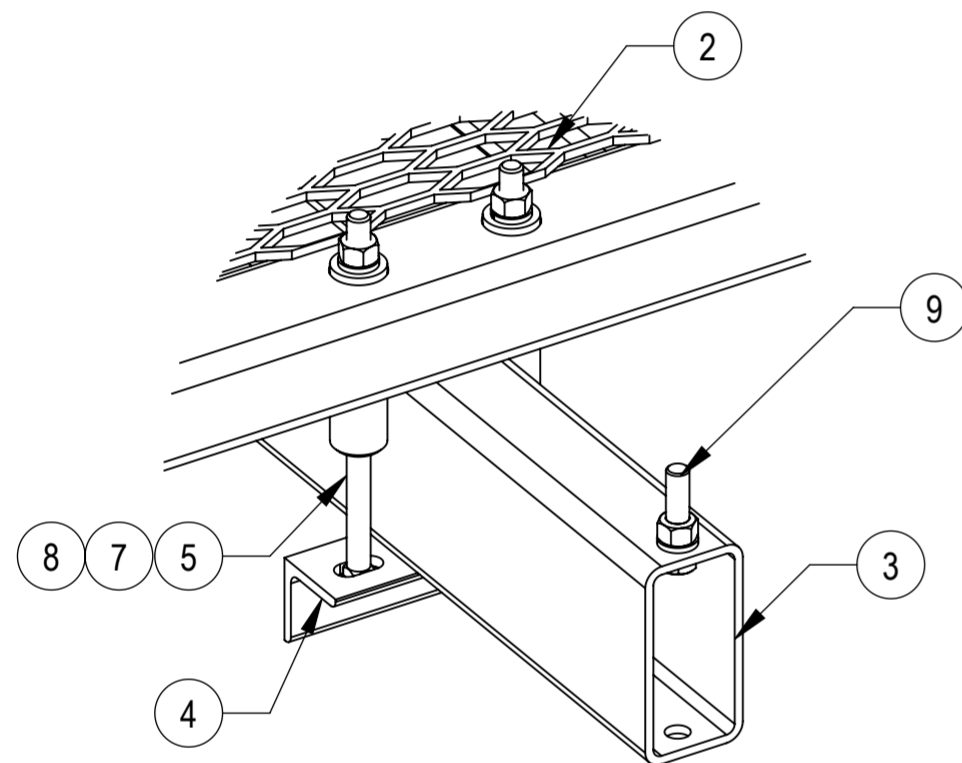

DETAIL M  
SCALE 1 : 5

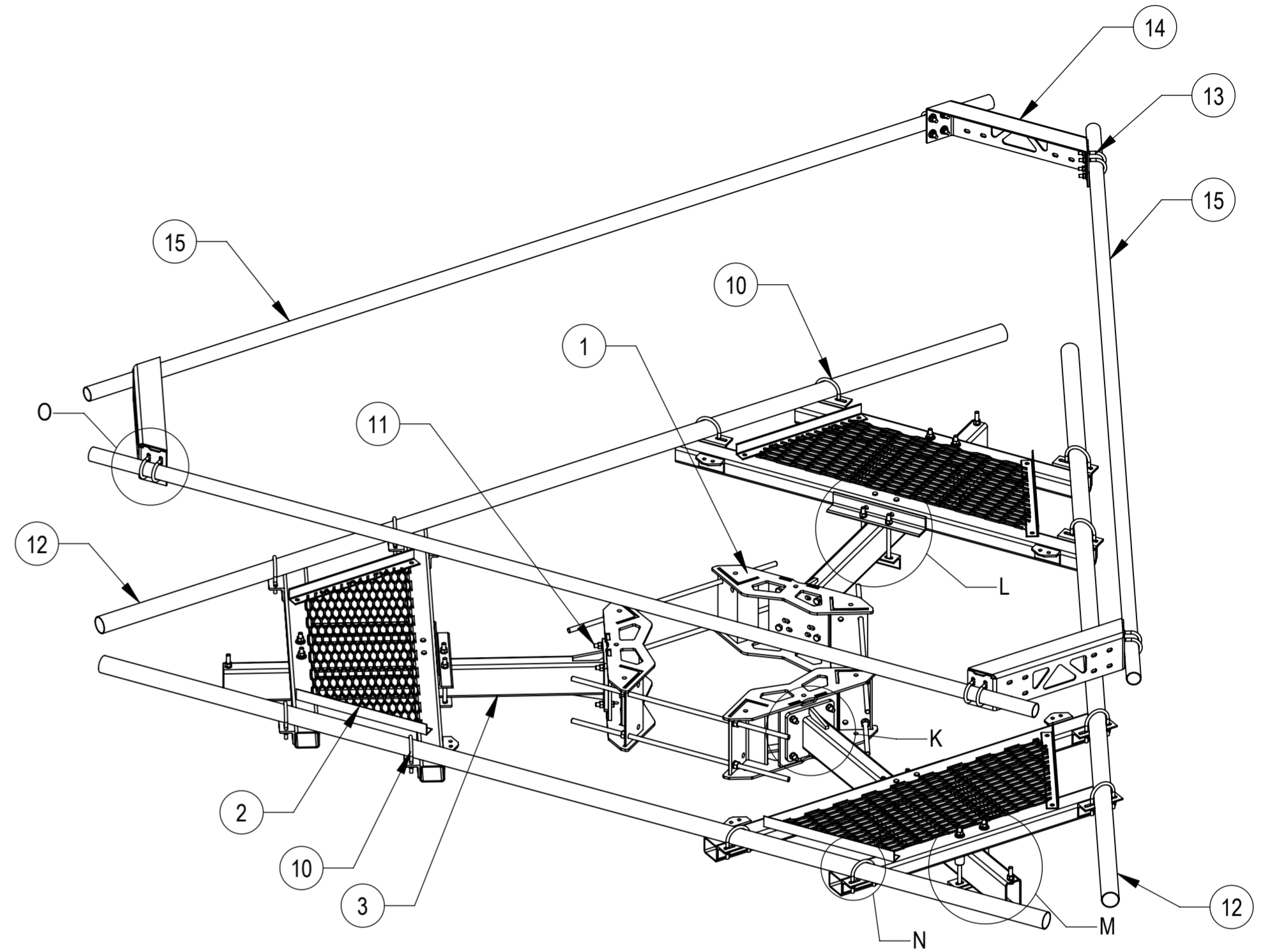

COMPONENT PART NUMBERS PROVIDED FOR ASSEMBLY PURPOSES;  
INDIVIDUAL COMPONENTS MAY BE SHIPPED AS PARTS WITHIN AN INCLUDED KIT.

ITEM NO.	PART NUMBER	DESCRIPTION	QTY.	WEIGHT	NOTE NO.
1	MC-RM1550-3	15" - 50" OD RINGMOUNT	1	229.90 LBS	
2	MC-AS-1100-00	WELDMENT, CO-LOCATION PLATFORM FRAME	3	145.67 LBS	
3	MC-AS-2000-00	WELDMENT, T-ARM SPINDLE	3	85.79 LBS	
4	MC-AS-1200-00	CLAMP PLATE, CO-LOCATION PLATFORM	6	2.93 LBS	
5	9615-13	BOLT,CARRIAGE,5/8-11,11,STL GALV	6	0.13 LBS	
6	9615-14	BOLT,CARRIAGE,5/8-11,8.5,STL GALV	6	0.11 LBS	
7	GWL-05	5/8" GALV LOCK WASHER	12	0.03 LBS	
8	GN-05	5/8" GALV HEX NUT	12	0.08 LBS	
9	GB-05245	5/8" X 2-1/2" GALV BOLT KIT	3	0.304 LBS	
10	GUB-4355	1/2" X 3-5/8" X 5" GALV U-BOLT	12	0.71 LBS	
11	GB-0524A	5/8" X 2-1/2" GALV BOLT KIT (A325)	12	0.305 LBS	
12	MT546174120	2.88" OD X 174" LONG PIPE	3	51.38 LBS	
13	GUB-4240	1/2" X 2-1/2" X 4" GALV U-BOLT	12	0.56 LBS	
14	MC-AS-3600-00	CORNER WELDMEMT, HANDRAIL	3	20.75 LBS	
15	MT537174	2.375" O.D. X 174" PIPE	3	42.15 LBS	

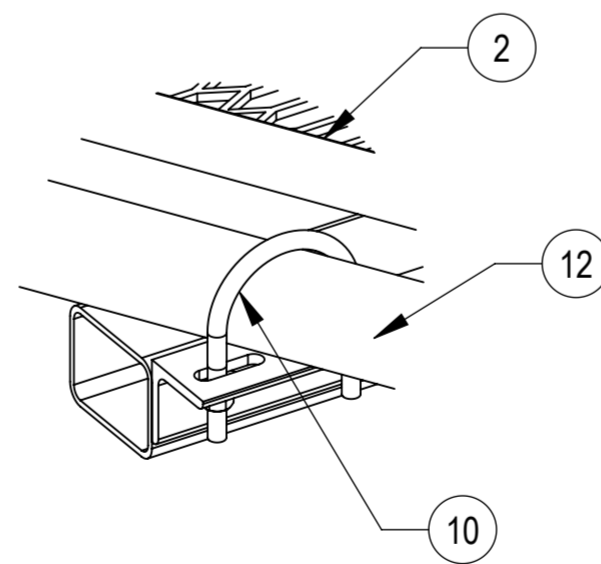

DETAIL N  
SCALE 1 : 5

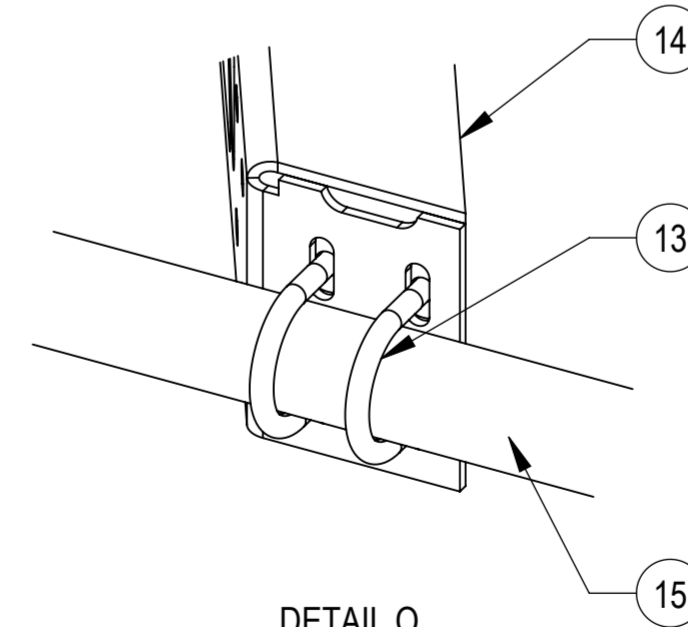

DETAIL O  
SCALE 1 : 4

COMMSCOPE, INC. OF NORTH CAROLINA

TITLE  
ADJ PLATFORM HR SERIES

SIZE A2 SCALE 1:20 DOCUMENT NO. MC-CP-J

DRAWING			SHEET
VERSION	STATUS	REVISION	
00	RE	A	7 OF 11

COMPONENTS FOR INSTALLATION  
MC-CP14M-12-96-J SHOWN ON THIS PAGE

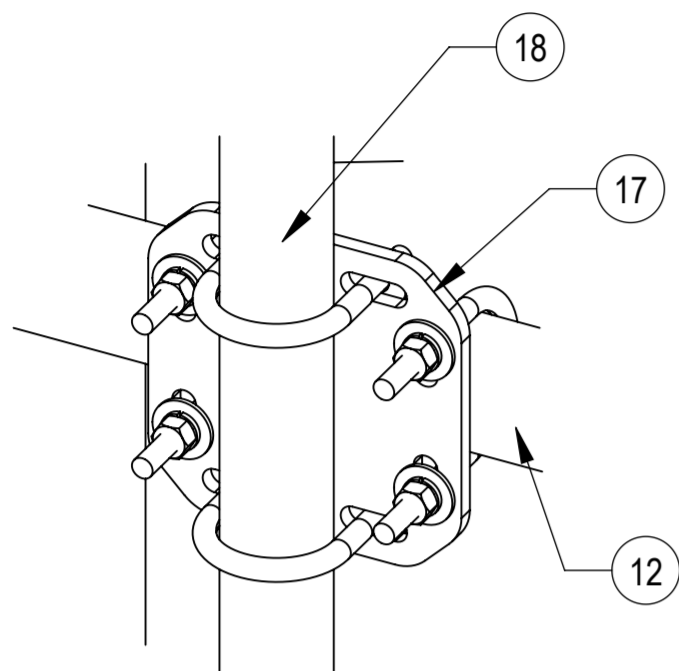

DETAIL Q  
SCALE 1 : 4

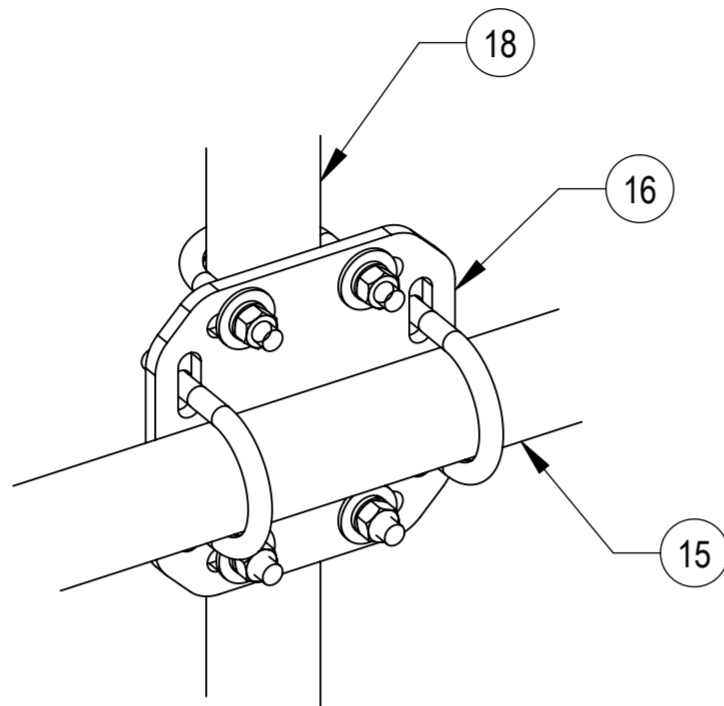

DETAIL P  
SCALE 1 : 4

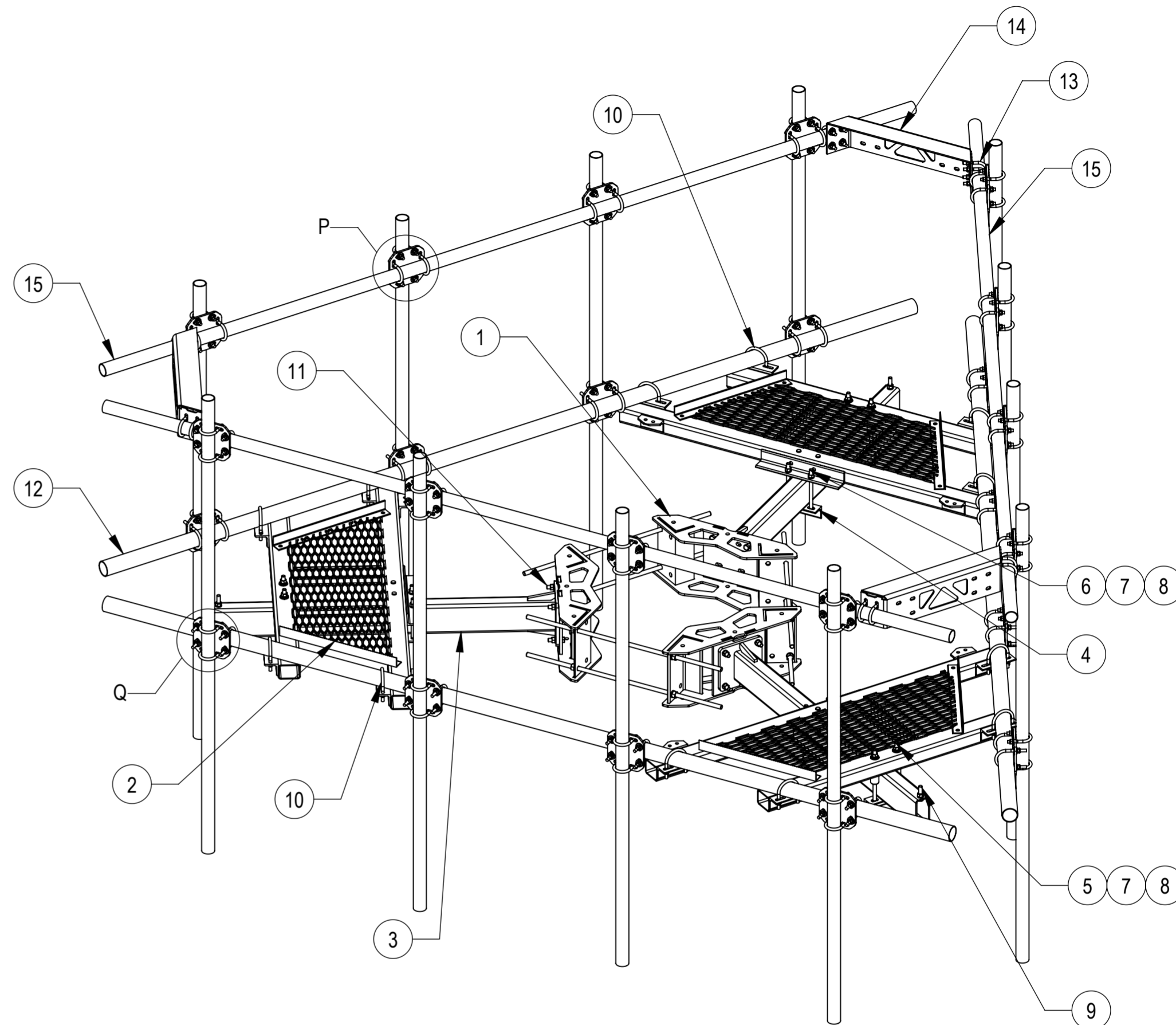

COMPONENT PART NUMBERS PROVIDED FOR ASSEMBLY PURPOSES;  
INDIVIDUAL COMPONENTS MAY BE SHIPPED AS PARTS WITHIN AN INCLUDED KIT.

ITEM NO.	PART NUMBER	DESCRIPTION	QTY.	WEIGHT	NOTE NO.
1	MC-RM1550-3	15" - 50" OD RINGMOUNT	1	229.90 LBS	
2	MC-AS-1100-00	WELDMENT, CO-LOCATION PLATFORM FRAME	3	145.67 LBS	
3	MC-AS-2000-00	WELDMENT, T-ARM SPINDLE	3	85.79 LBS	
4	MC-AS-1200-00	CLAMP PLATE, CO-LOCATION PLATFORM	6	2.93 LBS	
5	9615-13	BOLT,CARRIAGE,5/8-11,11,STL GALV	6	0.13 LBS	
6	9615-14	BOLT,CARRIAGE,5/8-11,8.5,STL GALV	6	0.11 LBS	
7	GWL-05	5/8" GALV LOCK WASHER	12	0.03 LBS	
8	GN-05	5/8" GALV HEX NUT	12	0.08 LBS	
9	GB-05245	5/8" X 2-1/2" GALV BOLT KIT	3	0.304 LBS	
10	GUB-4355	1/2" X 3-5/8" X 5" GALV U-BOLT	12	0.71 LBS	
11	GB-0524A	5/8" X 2-1/2" GALV BOLT KIT (A325)	12	0.305 LBS	
12	MT546174120	2.88" OD X 174" LONG PIPE	3	51.38 LBS	
13	GUB-4240	1/2" X 2-1/2" X 4" GALV U-BOLT	12	0.56 LBS	
14	MC-AS-3600-00	CORNER WELDMEMT, HANDRAIL	3	20.75 LBS	
15	MT537174	2.375" O.D. X 174" PIPE	3	42.15 LBS	
16	XP-2020	CROSSOVER PLATE KIT, 2-3/8 OD X 2-3/8 OD	12	7.77 LBS	
17	XP-2025	CROSSOVER PLATE KIT, 2-3/8 OD X 2-7/8 OD	12	8.07 LBS	
18	MT-651-96	2.375" OD X 96" PIPE	12	23.05 LBS	

COMMSCOPE, INC. OF NORTH CAROLINA				
TITLE ADJ PLATFORM HR SERIES				
SIZE A2	SCALE 1:20	DOCUMENT NO. MC-CP-J		
DRAWING		SHEET		
VERSION 00	STATUS RE	REVISION A	8 OF 11	



COMPONENTS FOR INSTALLATION  
MC-CP14M-12-126-J SHOWN ON THIS PAGE

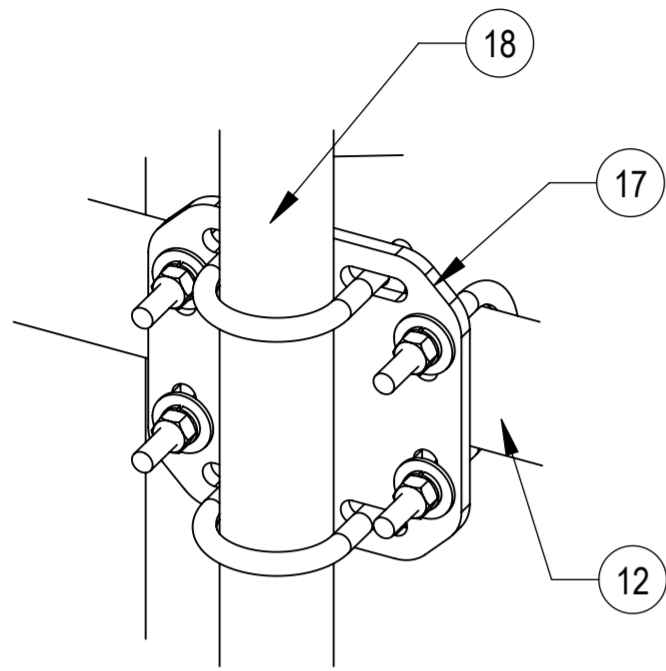

DETAIL R  
SCALE 1 : 4

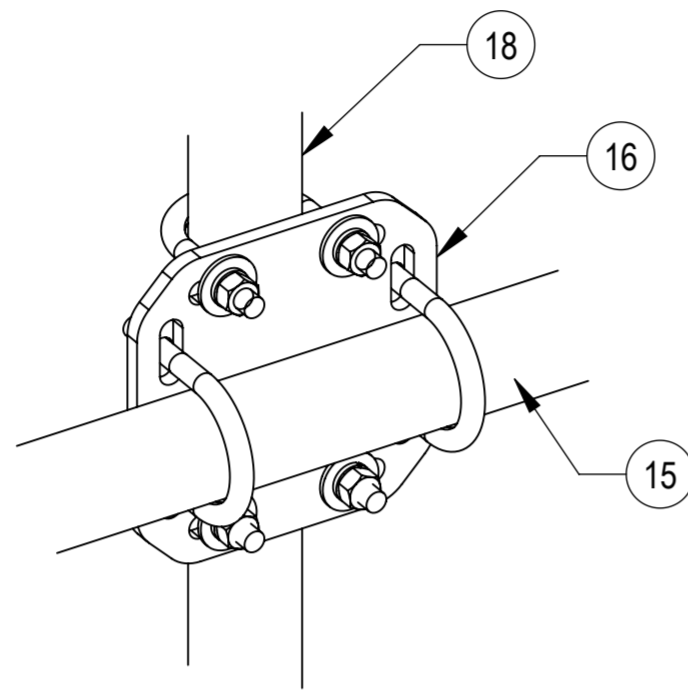

DETAIL S  
SCALE 1 : 4

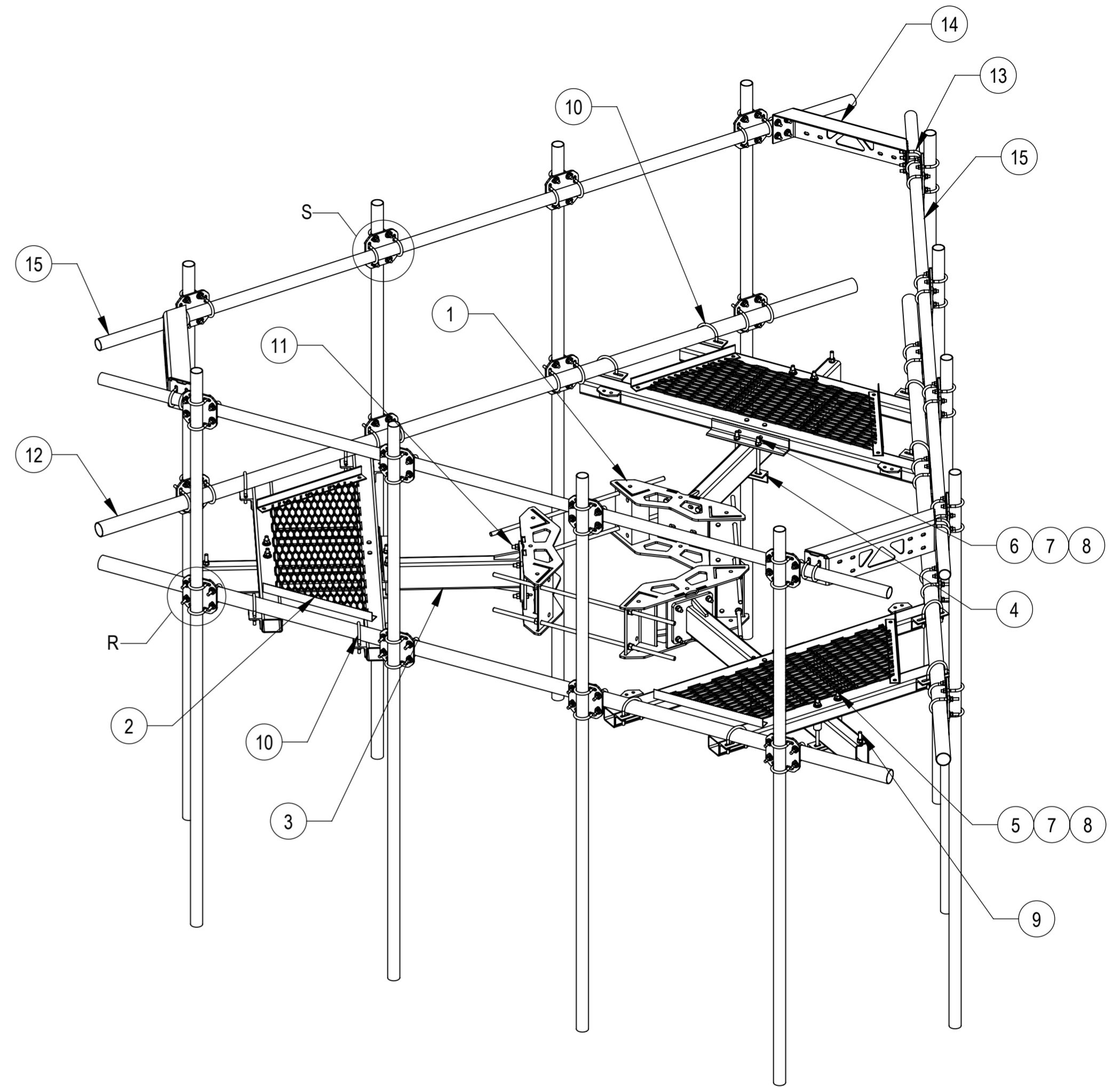

COMPONENT PART NUMBERS PROVIDED FOR ASSEMBLY PURPOSES;  
INDIVIDUAL COMPONENTS MAY BE SHIPPED AS PARTS WITHIN AN INCLUDED KIT.

ITEM NO.	PART NUMBER	DESCRIPTION	QTY.	WEIGHT	NOTE NO.
1	MC-RM1550-3	15" - 50" OD RINGMOUNT	1	229.90 LBS	
2	MC-AS-1100-00	WELDMENT, CO-LOCATION PLATFORM FRAME	3	145.67 LBS	
3	MC-AS-2000-00	WELDMENT, T-ARM SPINDLE	3	85.79 LBS	
4	MC-AS-1200-00	CLAMP PLATE, CO-LOCATION PLATFORM	6	2.93 LBS	
5	9615-13	BOLT,CARRIAGE,5/8-11,11,STL GALV	6	0.13 LBS	
6	9615-14	BOLT,CARRIAGE,5/8-11,8.5,STL GALV	6	0.11 LBS	
7	GWL-05	5/8" GALV LOCK WASHER	12	0.03 LBS	
8	GN-05	5/8" GALV HEX NUT	12	0.08 LBS	
9	GB-05245	5/8" X 2-1/2" GALV BOLT KIT	3	0.304 LBS	
10	GUB-4355	1/2" X 3-5/8" X 5" GALV U-BOLT	12	0.71 LBS	
11	GB-0524A	5/8" X 2-1/2" GALV BOLT KIT (A325)	12	0.305 LBS	
12	MT546174120	2.88" OD X 174" LONG PIPE	3	51.38 LBS	
13	GUB-4240	1/2" X 2-1/2" X 4" GALV U-BOLT	12	0.56 LBS	
14	MC-AS-3600-00	CORNER WELDMEMT, HANDRAIL	3	20.75 LBS	
15	MT537174	2.375" O.D. X 174" PIPE	3	42.15 LBS	
16	XP-2020	CROSSOVER PLATE KIT, 2-3/8 OD X 2-3/8 OD	12	7.77 LBS	
17	XP-2025	CROSSOVER PLATE KIT, 2-3/8 OD X 2-7/8 OD	12	8.07 LBS	
18	MT-537	2.375" OD x 126" PIPE	12	30.45 LBS	

COMMSCOPE, INC. OF NORTH CAROLINA				
TITLE ADJ PLATFORM HR SERIES				
SIZE A2	SCALE 1:20	DOCUMENT NO. MC-CP-J		
DRAWING		SHEET		
VERSION 00	STATUS RE	REVISION A	9 OF 11	

# RING MOUNT

MC-RM1550-3

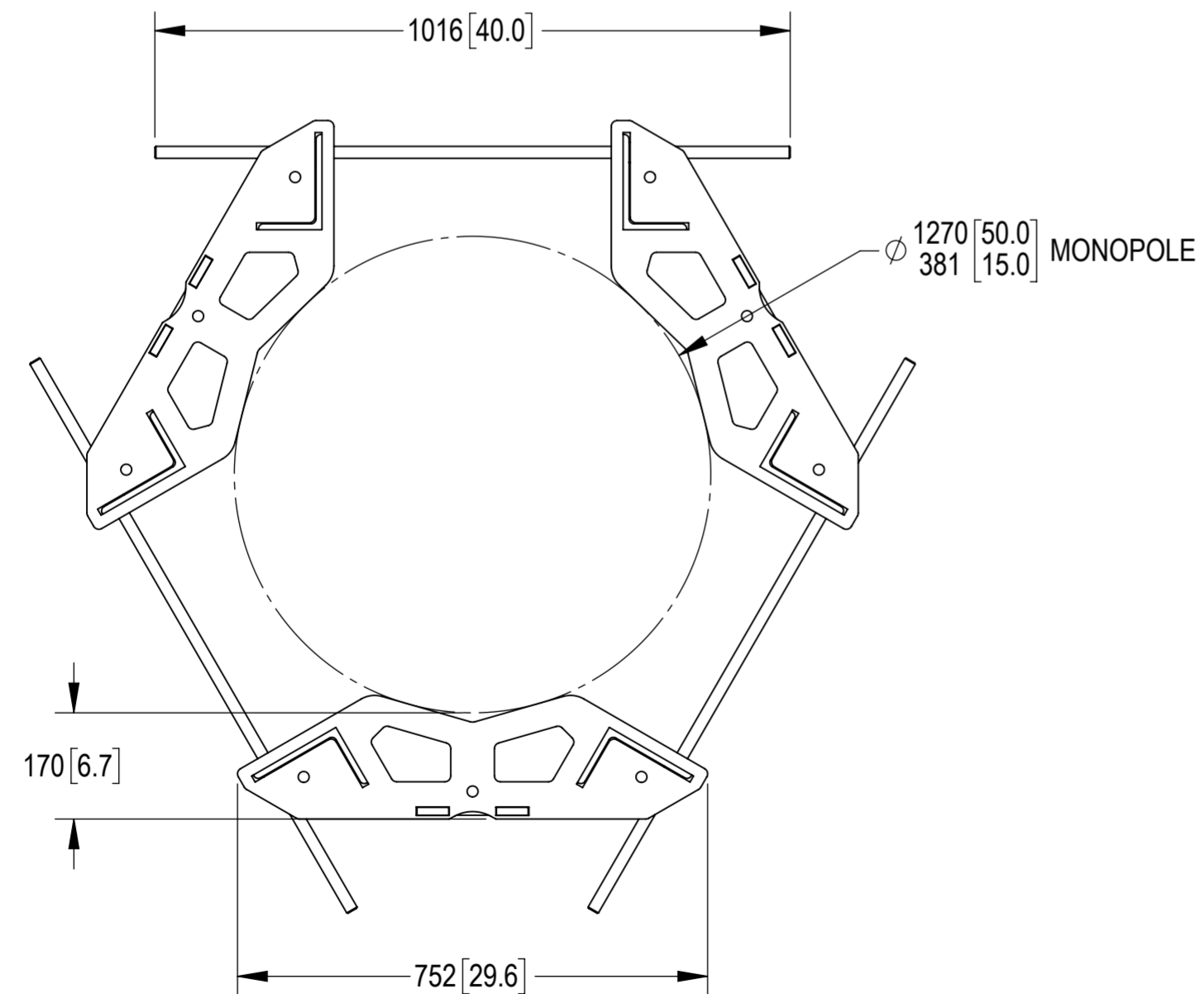
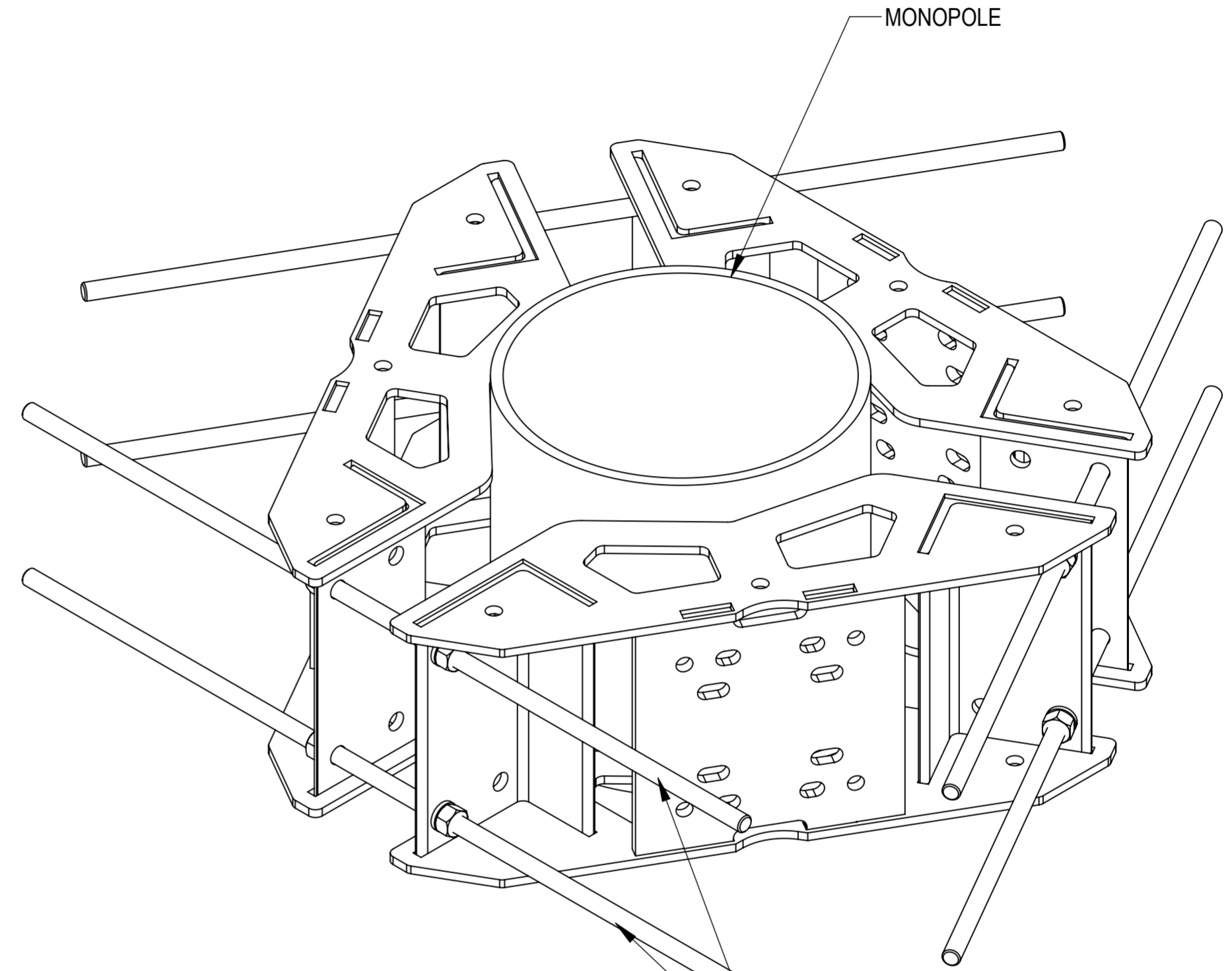
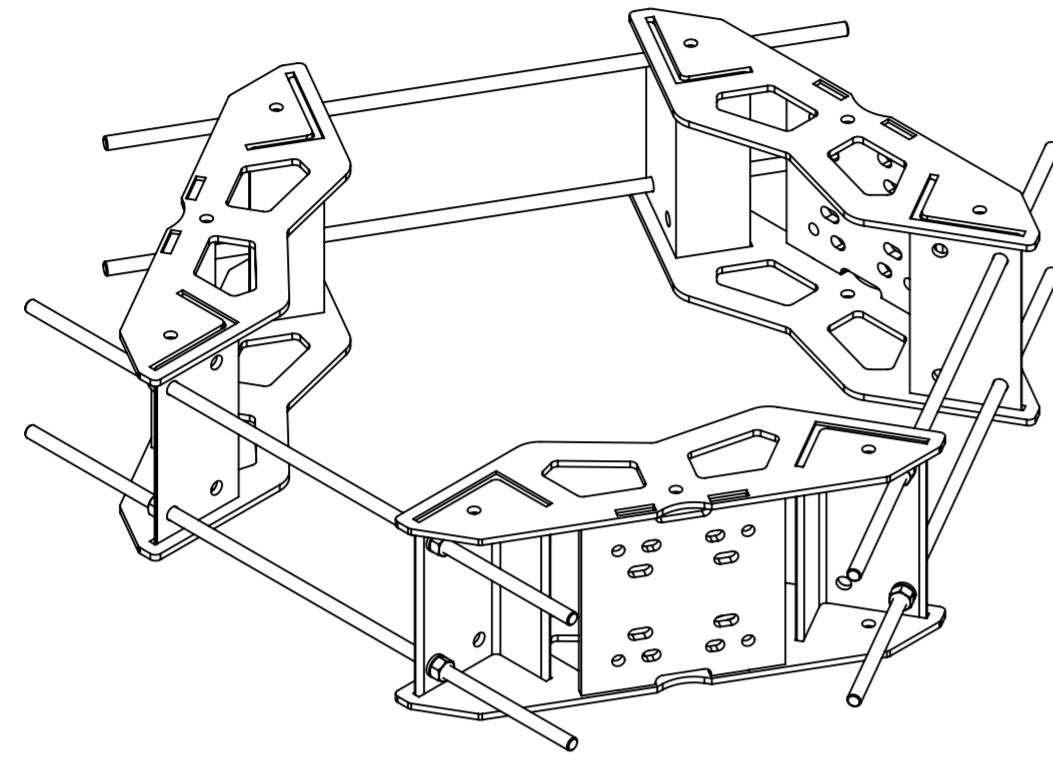

WHEN INSTALLED ADJACENT TO CLIMB PATH REMOVE EXCESS ALL-THREAD TO PROMOTE CLIMBER SAFETY AND PREVENT CONTACT WITH SAFETY CLIMB WIRE ROPE. MINIMUM 1" REQUIRED BEYOND HEX NUT

COMMSCOPE, INC. OF NORTH CAROLINA				
TITLE				
ADJ PLATFORM HR SERIES				
SIZE	SCALE	DOCUMENT NO.		
A2	1:20	MC-CP-J		
DRAWING				SHEET
VERSION	STATUS	REVISION	10 OF 11	
00	RE	A		

**OPTIONAL ACCESSORIES**

(ALL THE ACCESSORY ITEMS TO BE PURCHASED SEPARATELY)

**WALKWAY**

MOUNTS BETWEEN FACE PIPE AND COLLAR  
 CREATES WORKING SURFACE BETWEEN SECTORS

MC-AS-3000-00

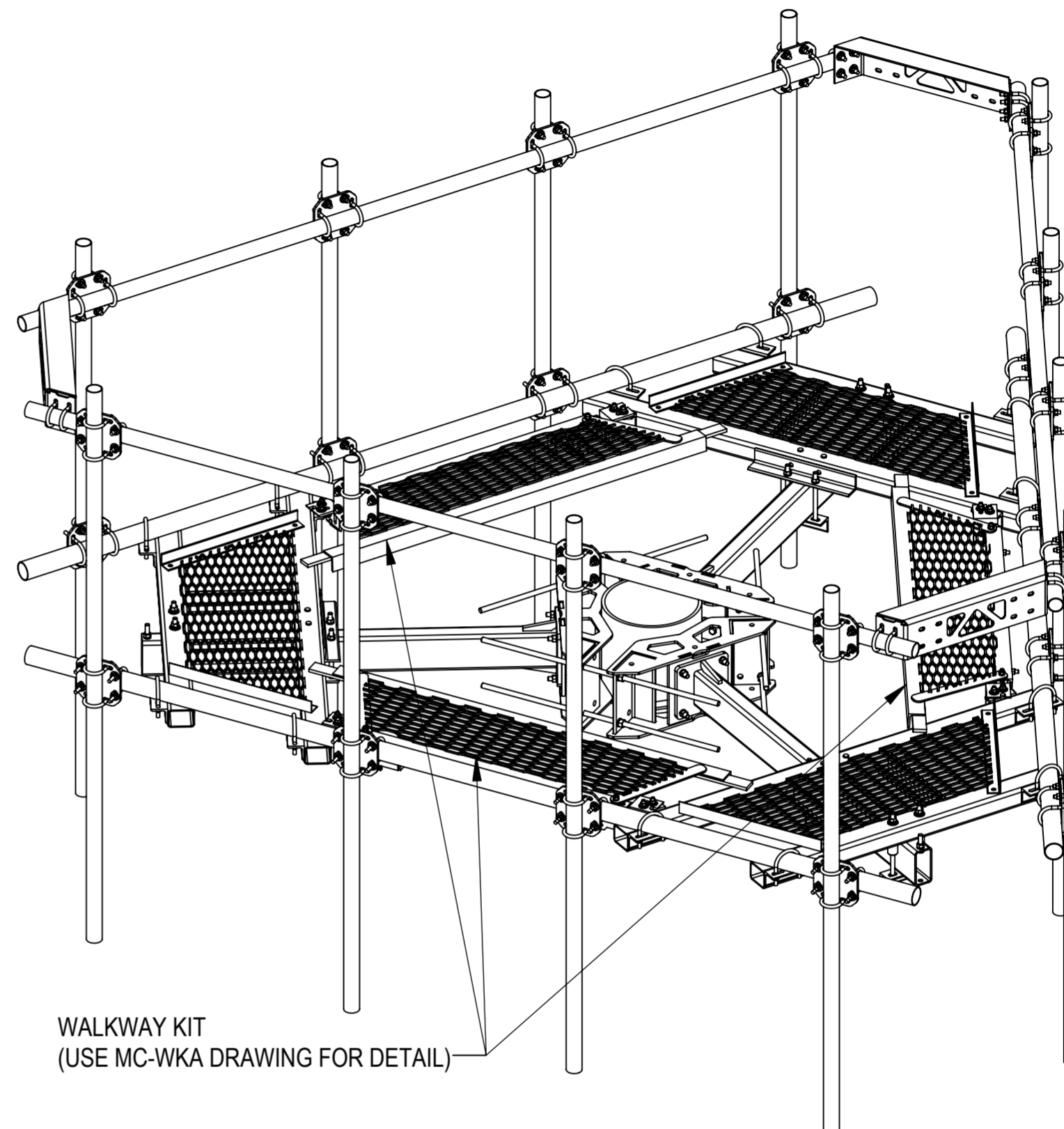
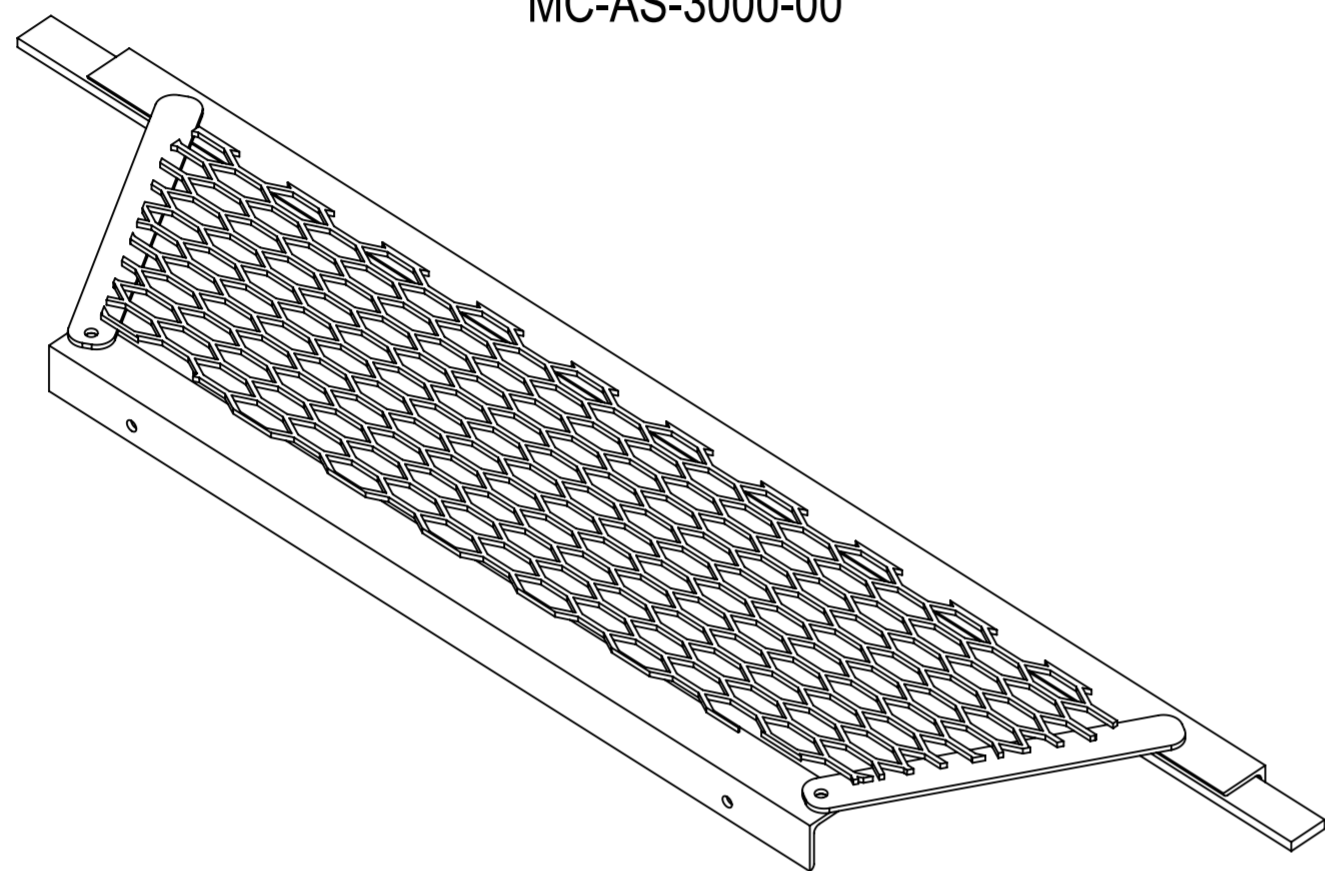

WALKWAY KIT  
 (USE MC-WKA DRAWING FOR DETAIL)

MC-CP12M-12-96-J WITH WALKWAY KIT  
 SHOWN FOR REFERENCE

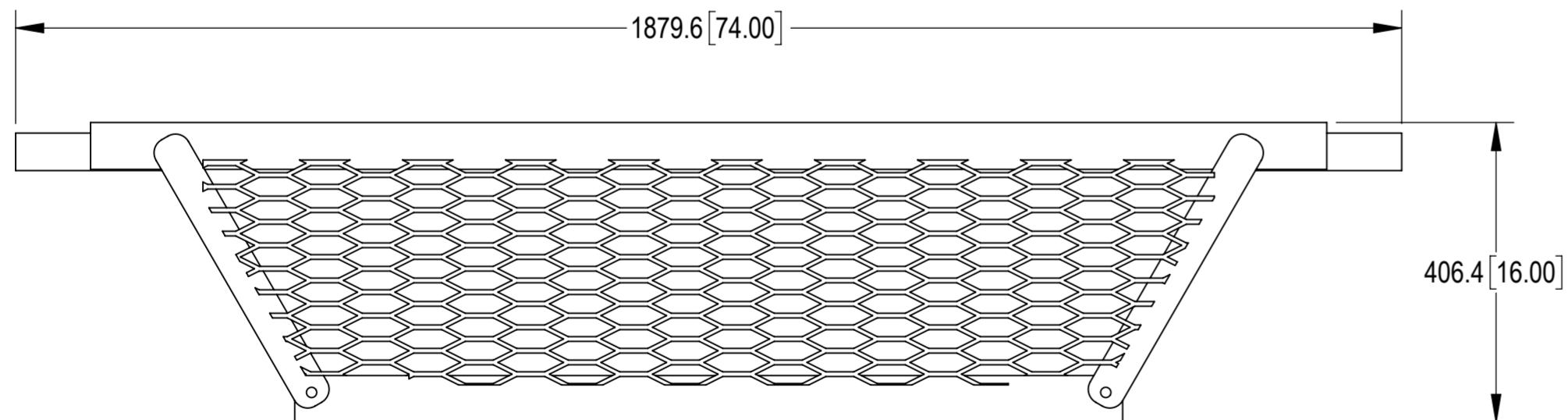

COMMSCOPE, INC. OF NORTH CAROLINA				
TITLE				
ADJ PLATFORM HR SERIES				
SIZE	SCALE	DOCUMENT NO.		
A2	1:20	MC-CP-J		
DRAWING				SHEET
VERSION	STATUS	REVISION	11 OF 11	
00	RE	A		